



Intel[®] Technology Journal

Second-Generation Intel[®] Centrino[™] Mobile Technology

Second-Generation Intel[®] Centrino[™] Mobile Technology Platform

Second-Generation Intel[®] Centrino[™] Mobile Technology Platform

Shreekant (Ticky) Thakkar, Mobility Group, Intel Corporation

Index words: CPU, GMCH, ICH, DDR2, WLAN, Audio, Power, Performance, Mobile, Notebook, Laptop, Centrino, Florence, Sonoma, Dothan, Alviso

ABSTRACT

In this paper, we provide an overview of the second-generation Intel[®] Centrino[™] mobile technology platform. This represents a major revision of several new I/O and memory interfaces: Peripheral Component Interconnect (PCI) Express* (PCIe), Serial Advanced Technology Attachment (SATA), Intel[®] High Definition Audio (Intel[®] HD Audio), and Double Data Rate (DDR2), which all enable a range of computing and media capabilities. The second-generation Pentium[®] M processor, the i915 Graphics and Memory Controller Hub (GMCH), the 82801FM I/O Controller Hub (ICH) and the Intel[®] PRO/Wireless 2915 Network Interface Controller (NIC) with higher performance, new capabilities and interfaces enable exciting new usages: Mobile Digital Office, Mobile On-the-Go, and Mobile Entertainment. Intel has demonstrated these usages through innovative concepts based on the Intel Centrino mobile technology platform and is actively enabling our Original Equipment Manufacturers (OEMs) and Original Design Manufacturers (ODMs) to bring these to market. Intel has driven power reductions on both the platform and its silicon while still delivering new features and capabilities.

INTRODUCTION

The mobile Personal Computer (PC) market segment has entered a period of rapid innovation driven by an accelerated demand for mobile devices and advances in mobile technologies that enable new mobile usage models.

[®] Intel is a registered trademark of Intel Corporation or its subsidiaries in the United States and other countries.

[™] Centrino is a trademark of Intel Corporation or its subsidiaries in the United States and other countries.

* Other brands and names are the property of their respective owners.

[®] Pentium is a registered trademark of Intel Corporation or its subsidiaries in the United States and other countries.

With the introduction of the first-generation Centrino mobile technology platform in 2003, the wireless LAN (WLAN) attached rate has climbed from under 20% to over 65% in 2004. According to industry analysts, IDC, more than 95% of all notebook PCs are expected to have integrated WLAN capability by 2006. This will complete the notebook transition from a portable to a wireless device.

Also, IDC expects that by the end of 2005, there will be over 150,000 WLAN hotspots around the world, nearly a 300% increase from 2003. Hotspot growth enables users to access critical data needed to make decisions, stay informed, and communicate while on-the-go. This growth in WLAN hotspots is expected to help drive a tenfold increase in the number of frequent WLAN hotspot users from less than 1 million in 2002 to over 10 million in 2004, and expanding to over 30 million by 2006.

Users view the notebook as the preferred mobile device to access wireless messaging content. Over the past few years computer mobility is part of many lifestyles: businesses, students, and home users have clearly recognized the flexibility and productivity benefits of having notebooks with wireless connectivity. Enterprise IT managers have been moving wireless deployments from prototype to production resources and enabling more notebooks with wireless access. According to industry analyst, Gartner (Dec. 2003), Mobile PC Notebook CAGR is 17% for 2002-2007.

Intel introduces the second-generation platform built on Intel Centrino mobile technology (previously codenamed Sonoma) in 2005 to continue driving growth in mobility through its vision. This platform represents a new building block with new interfaces, features, and performance that enable exciting new usages for second-generation mobile form factors. We briefly discuss technologies, features, and usage models in this paper.

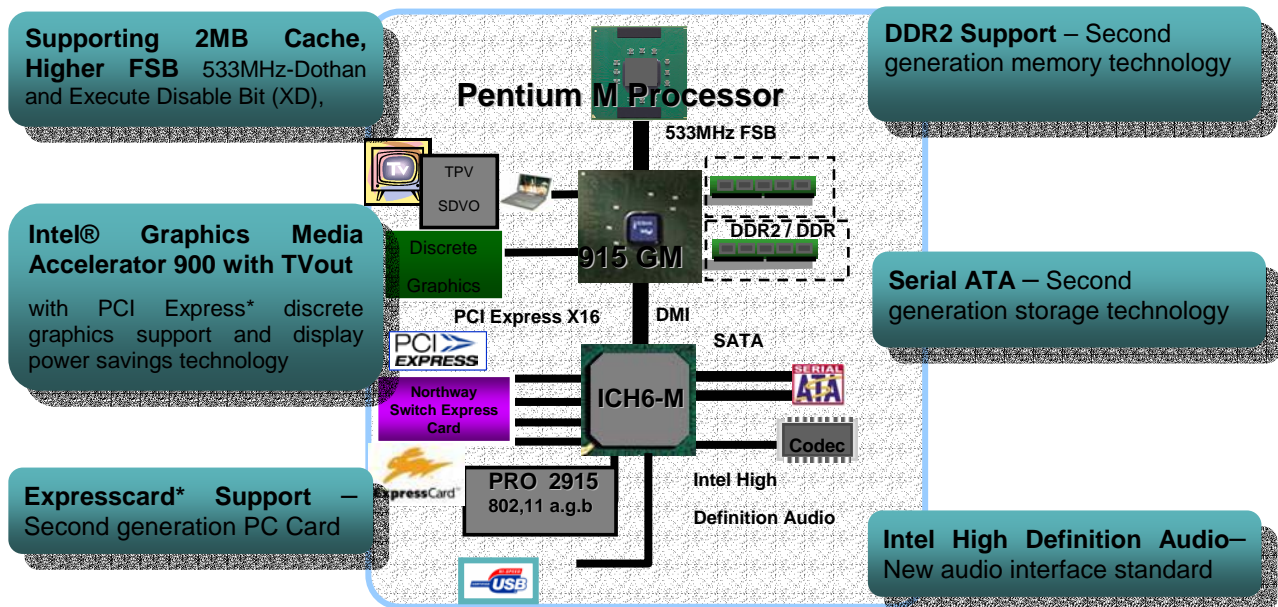

Figure 1: The second-generation platform built on Intel Centrino mobile technology

Intel’s mobility vision revolves around the four vectors of mobility that drive mobile PC capabilities: breakthrough mobile performance, integrated Wireless LAN (WLAN) capability, great battery life, and thinner, lighter designs. Newer capabilities will continue to emerge to build on the foundation of these vectors and provide future users with an advanced and compelling mobile computing experience for the wireless communications environment and anywhere, anytime computing.

NEW PLATFORM

The second-generation platform built on Intel Centrino mobile technology (Figure 1) continues to excel on the four vectors of mobility. It comprises the Intel Pentium M processor, the i915 Graphics and Memory Controller Hub (GMCH), the IO Controller Hub (ICH) 6-M, and the Intel PRO/Wireless 2915 a/b/g Network Interface Controller (NIC). It introduces several new technologies that make it a new building block for this decade: mobile PCI Express (PCIe) and ExpressCard* technology, Serial Advanced Technology Attachment (SATA) interface, PCIe External Graphics (PEG) interface, Intel High Definition (HD) Audio, and Double Data Rate (DDR2) memory.

* Other brands and names are the property of their respective owners.

This new platform delivers both on CPU and graphics performance through scaling in core and bus frequencies as well as with microarchitecture enhancements including doubling processor cache size. The graphics performance improves by 2x over the previous-generation platform. GMCH enables an enriched media experience through incorporation of Intel HD Audio and higher-speed interfaces.

Various platform power-savings techniques are used in all Intel silicon to reduce the power consumption of the platform while still providing the new features that demand higher power. Intel has also been working with the Industry to drive lower power displays, reducing power from over 4.5 W for 14” XGA LCD to under 3 W. The display vendors have shipped over 4M such units in the past year. Thus, battery life on the second-generation platform built on Intel Centrino mobile technology stays the same as the previous generation with integrated graphics, even though graphics performance has been doubled in the second-generation platform.

Wireless connectivity is enhanced with industry-standard WLAN security support (such as WPA2 and Cisco* Compatible Extensions v.3), a new user interface for

* Other brands and names are the property of their respective owners.

ease of connectivity, and support of a wireless coexistence solution that mitigates interference with wireless Bluetooth¹ human interface devices (HIDs).

Smaller mobile form factors (mini and subnotebooks) are now enabled through the introduction of new smaller chipset packages.

NEW INTERFACES

PCIe introduces a scalable, point-to-point, power-managed, serial interface. Full isochronous data transfer support is provided to guarantee minimum service latency and bandwidth requirements. This mode is advantageous for isochronous or time-sensitive applications, such as streaming video, where it is more important to display frames in a timely fashion than it is to display every frame. The Mobile PCIe Mini Card and ExpressCard interfaces enable a new level of interconnect performance on mobile platforms upgrading the I/O bandwidth from a half-duplex 133 MB/s to a full-duplex 250 MB/s. The PCIe Mini Card replaces the Mini PCI card, typically used on the mobile motherboard for build-to-order optional functions. The ExpressCard module is a new add-in card that replaces the CardBus PC Card. Both of these new cards provide not only PCIe bus connectivity but also USB 2.0 connectivity through the same connector. The PCIe Mini Card (30 mm x 51 mm) is about half the size of the Mini PCI (61 mm x 51 mm) card, thus two PCIe Mini Cards can fit in the space for one Mini PCI card. The ExpressCard module comes in two sizes: One is 40% the size of the PC Card for small mobile small factors, and the other is 80% the size of the PC Card for larger mobility notebooks. The ExpressCard technology will also appear on desktops.

SATA is the evolution of the Parallel ATA (PATA) bus for connecting mass storage (hard and optical drives) on mobile platforms initially upgrading the transfer rate from 133 MB/s to 150 MB/s with ability to scale to 300 MB/s and 600 MB/s in future. SATA is also friendly to mobile form factors since it needs a much smaller connector than PATA. Also, both PCIe and SATA were designed from the ground up to be better power managed than their predecessors. Because of higher transfer rates they consume higher power during transfers. However, overall they will use less power since the work (transfer) is done quicker than it was done with previous-generation interfaces. From a power-management perspective, it is best to get work done quickly in mobile

platforms and then power down the link versus taking a longer time using less power.

Finally, the second-generation platform built on Intel Centrino mobile technology introduces Intel HD Audio which delivers significant improvements over AC'97 previous-generation integrated audio and sound cards. Intel HD Audio hardware is capable of delivering the support and sound quality for up to eight channels at 192 kHz/32-bit quality, while the AC'97 specification can only support six channels at 48 kHz/20-bit. This new platform can support three external codecs with isochronous data transfers. In addition, Intel HD Audio is architected to prevent the occasional glitches or pops that other audio solutions can have by providing dedicated system bandwidth for critical audio functions. Intel HD audio offers considerable power savings (over 700 mW) for media-oriented workloads such as DVD and CD audio playback because it supports power management by allowing the processor to run in lower power states. Additionally, Intel HD Audio enables Dolby 5.1/7.1 surround sound audio out capability, which can be used with an SPDIF optical interface for component audio amplifiers.

To support PCIe, SATA, and Intel HD Audio, a newer cross-chip interconnect, Direct Media Interface (DMI), between the GMCH and the ICH, was developed. This upgraded the cross-chip transfer rate from 266 MB/s to 2 GB/s. The DMI enables concurrent traffic and isochronous data transfer capabilities.

Platforms based on this new mobile technology support next-generation memory technology by implementing the DDR2 specification, an evolutionary technology that extends first-generation DDR (supported on the first Centrino mobile technology platforms). The new mobile technology platforms (i.e., GMCH) also introduce a second memory channel to system memory, effectively doubling the total available memory bandwidth especially for graphics' workloads. With dual-channel DDR2 memory support, these systems have increased peak bandwidth and lower per-SO-DIMM power consumption over first-generation Intel Centrino mobile technology platforms. The DDR2 specification allows increased clock rates over DDR while operating at 1.8 V vs. 2.5 V on earlier-generation technology. These platforms also support a peak bandwidth of 4.3 GB/s, a 60% increase over first-generation Intel Centrino mobile technology platforms, having a peak bandwidth of 2.7 GB/s (DDR 333 MHz). Together with the second channel, overall bandwidth of memory sub-subsystems will be around 8.5 GB/s.

¹ Bluetooth is a trademark owned by its proprietor and used by Intel under license.

NEW COMPONENTS

Intel's next-generation Pentium M (codename Dothan) processor implemented using Intel's 90nm technology has a number of new features. These include the L2 cache that has been doubled to 2 MB and at the same time optimized for reduced power. The Front-Side Bus (FSB) has been increased from 400 MHz to 533 MHz, and the available CPU frequencies have also been increased. Microarchitecture implementation has been optimized for performance and the Execute Disable Bit (XD) has been added to harden against buffer overflow virus attacks.

The i915 (codename Alviso) GMCH is the integrated GMCH for the second-generation platform built on Intel Centrino mobile technology delivering over 2x improvement in graphics performance over the previous 855GM controller. The i915 supports several newer and faster interfaces such as a 533 MHz FSB, two DDR2 Memory Channels, PEG (PCIe 16x) and a DMI link to ICH6-M. The integrated graphics controller includes support for Pixel Shader 2.0 and Microsoft Windows* DX9 Graphics API, integrated TVout, and improved power and performance techniques such as Display Power Savings Technique 2 (DPST2), Intel Dual Frequency Graphics (IDFG), and Frame Buffer Compression (FBC) as well as techniques to increase processor C3/4 residency, thus decreasing average power consumption. There is also use of a virtual thermal sensor to help manage thermal throttling and shutdown. GMCH comes in two packages (Intel 915GM and Intel 915GMS) supporting full and reduced functionality to accommodate different form factors.

The Intel 82801FM ICH (ICH6-M) comprises newer interfaces: PCIe, SATA with an Advanced Host Controller Interface (AHCI), and Intel HD Audio devices to connect current and the next generation of high-performance and lower-power peripherals. In addition to these new interfaces, ICH6-M provides support for USB 1.1/2.0 as on the previous-generation ICH4-M, but it adds two additional ports. The ICH6-M also provides the interface for the Intel PRO/Wireless 2915ABG wireless module and ExpressCard devices. The latter removes the need for an additional PCMCIA controller, thus saving cost while providing higher performance and form-factor-friendly connectivity.

Finally, WLAN communication is provided by the Intel PRO/Wireless 2915ABG NIC. It supports 802.11a,

802.11b, and 802.11g with the Intel Wireless Coexistence System (WCS) II that mitigates wireless interference with wireless Bluetooth devices, for e.g., headsets. This solution also supports industry-standard wireless security features including WPA2 and Cisco Compatible Extensions v3. The Intel PRO/Wireless 2915 NIC also supports the EAP-SIM protocol that allows SIM credentials to be accessed from the WWAN GSM/GPRS add-in card or add-in USB SIM reader for use in WLAN authentication and billing. This would enable carriers with the qualified WWAN add-in cards or USB SIM Reader to provide One-Bill Roaming (OBR) capability for WLAN hotspots and WWAN usage.

The increased convenience of on-demand connectivity will result in a new set of requirements to address users' needs to maintain the value of being connected while they are in transit or while the notebook lid is closed. To address these needs, Intel introduces Extended Mobile Access (EMA) capability, which enables the notebook to become a more useful tool to the user all day long.

In 2005, EMA features will include a small external display (Figure 1), similar to what has been available on some new cell phones, that provides the user with quick access to calendar, contact, and e-mail information, as well as alerts, reminders, and network availability and connection status. Running in a low-power state, the mobile notebook will provide critical information without unnecessary drain on the battery. We believe this capability will become a standard one especially with the introduction of support for auxiliary displays in the next generation of the PC client operating system.

NEW USAGES

The second-generation platform built on Intel Centrino mobile technology enables new mobile usages with the above technologies and features. We divide these usages into three key categories: Mobile Digital Office, Mobile On-the-Go, and Mobile Entertainment (Figures 2a, b, c).

* Other brands and names are the property of their respective owners.



Figure 2(a): Mobile Digital Office



Figure 2(b): Mobile On-the-Go



Figure 2(c): Mobile Entertainment

Mobile Digital Office

This usage is the evolution of the enterprise portable computer to a wirelessly connected mobile notebook. Our vision for this notebook is that it be an always-available virtual office with the following four pillars of the Digital Office:

- Embedded IT—making manageability and security transparent.
- Pervasive Connectivity—making wireless connectivity as easy as with a cell phone.
- Instant Teamwork—making collaboration spontaneous.
- Information Assistant—ready to relieve users from mundane tasks by anticipating their needs.

The second-generation platform built on Intel Centrino mobile technology takes a first step towards making this

vision a reality by driving delivery on the key pillars of the Digital Office. The Pentium M processor supports the XD bit that prevents buffer overflow type virus attacks. The Intel PRO/Wireless 2915 NIC supports all security standards and offers OBR capability to make connectivity easier between WLAN hotspots and WWAN (GSM/GPRS) through the use of SIM credentials. The second-generation platform also delivers the next iteration of the Intel Stable Image Platform Program (single set of drivers) for facilitating better manageability by reducing client environment complexity, which consequently reduces total cost of ownership.

With rapid adoption of Voice-Over-IP (VoIP), the mobile PC is the platform of choice for providing access to the office phone while at home or on the road, and for voice and video conferencing. Intel HD Audio provides a better way of attaching array microphones to the platform, thus delivering a great audio experience for collaboration through VoIP calls, rivaling the \$200 price tag of a

discrete microphone array used in high-end conference rooms. The CPU performance of the next-generation Pentium M processor is used for echo cancellation, ambient noise reduction, and optimization of codecs. Intel Wireless Coexistence System II in the Intel PRO/Wireless 2915ABG NIC mitigates interference resulting from overlapping harmonics of WLAN and Bluetooth radios operating in the same frequency spectrum. This enables the use of Bluetooth headsets for VoIP calls and for listening to music.

In order to inspire and demonstrate these usage models, Intel showcased the Florence Concept Family based on our new platform in the Spring of 2004 at the Intel Developers Forum. The first concept is the Florence 15" (Figure 3), and it delivers the promise of Digital Office as described with array microphones and camera for a great collaboration experience, a 15"-wide screen with a 16:9 aspect ratio for a great viewing experience, a finger print sensor for easier log in, and an EMA module for access to information on the go. This notebook also has an ExpressCard slot, a DVI connector, and a Smartcard slot for industry-standard smartcards. The system is based on the Intel Centrino mobile technology platform with a standard-voltage Pentium M processor, a 915 chipset, and an Intel PRO/Wireless 2915 NIC.

Intel is actively enabling ODMs and OEMS to make these Digital Office features part of their enterprise notebook offering starting in 2005.

Mobile On-the-Go

This usage is optimized for mobility in or out of the office or home, for productivity, entertainment, and communication. Highly mobile users prefer flexible thin and light mobile systems with optimized battery life. Flexibility allows the system to be used as a tablet or as a notebook either convertible or detachable. The system can be used to do all the work done on a Digital Office notebook while on the move. These systems can also acquire and view content such as photos, TV programs, music, or movies on a home network for consumption outside the home.

The second member of the Florence concept family is the 12" On-the-Go concept (Figure 4). This enables users to use it as a detachable tablet or as a laptop. It features array microphones, camera, finger print sensors, EMA display, and Bluetooth connectivity just like the Digital Office concept. Both the tablet and base with keyboard have lithium polymer battery packs for maximum battery life. The system also features a lower-power Low Temperature Poly Silicon (LTPS) display to enable lower average power, further enhancing the battery life of the platform. This concept is built on the Intel Centrino mobile technology platform and uses the ultra-low-voltage Pentium M processor, the 915 chipset, and Intel PRO/Wireless 2915 NIC, and it is passively cooled. It uses a 1.8 in. hard and optical drive.

Several OEMS, since the introduction of these concepts, have produced these kinds of detachable tablet/notebook systems.



Figure 3: The Florence 15''



Figure 4: The Florence 12''

Mobile Entertainment

This usage is optimized for entertainment: viewing movies, watching TV, sharing and editing photos, and playing games anywhere in the home. The Mobile Entertainment PC provides a consumer electronics experience with added PC functionality in a portable, all-in-one form factor allowing the user to bring the PC and

entertainment experience to more communal areas of the home, such as the kitchen or living room. The mobile entertainment PC is also a rich communications platform allowing users to make voice or video calls and create a “virtual gathering” with friends and family far away. This platform represents the convergence of computing, communications, and entertainment.



Figure 5: The Florence 17''

The final member of the 2004 Businessweek/IDA Gold award-winning Florence concept family is a 17'' Mobile Entertainment PC (Figure 5). This innovative design turns a PC into a Digital Home Consumer Device. Its main usage is entertainment and communications, but when needed is also a high-performance wireless portable computer. The industrial design of this system reflects this usage; it looks like a 17'' LCD TV screen with a stand, but hidden behind the stand are a wireless Bluetooth keyboard, remote control, and VoIP handset. These peripherals can be detached from the base and moved 6-10 feet away for viewing. The system is based on the second-generation Intel Centrino mobile technology platform with a standard-voltage Pentium M processor, a 915 chipset, and the Intel PRO/Wireless 2915 NIC. It delivers a HDTV-quality video experience and a good gaming experience with 915 graphics performance. Additionally, it incorporates array microphones and a camera, just like the two other members of the Florence family, to deliver a great virtual gathering experience with family and friends. The latter is now possible with broadband services delivered to a large percentage of homes. The Florence 17'' screen is also a wireless TV (without a tuner) that receives TV broadcast over Intel PRO/Wireless 2915 NIC from a wireless TV receiver connected to a cable or satellite source. Such devices are now sold by Sony and Sharp to work with wireless TVs operating over IEEE 802.11a/b/g WLAN. The Florence family also uses Intel HD Audio to provide Dolby 5.1/7.1

surround sound audio with an SPDIF optical interface that can be interfaced with a component audio amplifier.

Intel is enabling these kinds of consumer systems for introduction in 2005. We expect this trend to continue with larger screen sizes. Our vision is to see every TV integrated with Intel Centrino mobile technology to provide a rich entertainment, communication, and computing experience.

CONCLUSION

The second-generation platform built on Intel Centrino mobile technology excels on the four vectors of mobility delivering more performance through microarchitecture feature enhancements, 90nm process technology, and new interfaces while keeping the battery life of the platform the same as that of previous-generation technologies. These new interfaces, performance, and capabilities unleash exciting Mobile Digital Office, Mobile On-the-Go, and Mobile Entertainment usage models. Intel demonstrated these usage models through innovative concept platforms and are continuing to enable our OEMs and ODMs to include these capabilities in the next generation of mobile platforms.

ACKNOWLEDGMENTS

We acknowledge all the members of the second-generation Centrino mobile technology platform and the Mobile Concept team for their dedication in making this platform happen. And special thanks to Tom Shewchuk for his dedication and help in guiding the development of this issue of Intel Technology Journal. And an additional acknowledgment to Judith C. Anthony for coordinating a seamless issue.

AUTHOR'S BIOGRAPHY

Dr. Shreekant (Ticky) Thakkar is the director of mobile technology and is the Mobile visionary in Intel's Mobility Group. He has over 26 years of experience in various development and planning positions at Intel and Sequent (now part of IBM). Dr. Thakkar was a key driver in establishing the direction for mobile notebook PCs to transition from portable to wireless computing with Intel's Centrino mobile technology. Recently, he drove the convergence of computing, communications, and entertainment in the Mobility Group's Florence Concept Platform. Dr. Thakkar also created the Mobile Platform Architecture team within the Mobility Group. Prior to the Mobility Group, he was the general manager of a new business unit, Persona, which delivered smart proactive services over wired and wireless devices. At Intel, he also led the team that developed the Pentium Pro MP (Intel®

Xeon™ processor) as well as teams that developed Multimedia/Graphics Media (SSE) extensions to the Pentium III and 4 processors. Among Dr. Thakkar's many accomplishments was bringing the Pentium Pro MP (Intel Xeon) processor to market in record time, 11 months from first silicon to production. He has led the development of security functionality in Intel's processors and chipsets and fills the roadmap planning role for Intel's microprocessor family. Prior to Intel, Dr. Thakkar pioneered the development of Shared Memory Multiprocessors and Databases on these systems at Sequent Computer Systems

Dr. Thakkar holds a Ph.D. degree, an M.S. degree in Computer Science/Engineering from the University of Manchester (England), and a B.S. degree in Computer Science/Statistics from the University of London. He holds or has pending applications for over 50 patents. Dr. Thakkar has published numerous articles and edited special editions of IEEE journals. His e-mail is ticky.thakker at intel.com.

Copyright © Intel Corporation 2005. This publication was downloaded from <http://www.intel.com/>.

Legal notices at <http://www.intel.com/sites/corporate/tradmarx.htm>.

™ Xeon is a trademark of Intel Corporation or its subsidiaries in the United States and other countries.

For further information visit:

developer.intel.com/technology/itj/index.htm