



Intel® RAID Controller SRCASJV

Technical Product Specification

Intel order number D97421-001

Revision 1.0

July 2007

Enterprise Platforms and Services Marketing

Revision History

Date	Revision Number	Modifications
April, 2007	0.8	Initial Release
July, 2007	1.0	Updated shipping mini-DIMM size

Disclaimers

INFORMATION IN THIS DOCUMENT IS PROVIDED IN CONNECTION WITH INTEL® PRODUCTS. NO LICENSE, EXPRESS OR IMPLIED, BY ESTOPPEL OR OTHERWISE, TO ANY INTELLECTUAL PROPERTY RIGHTS IS GRANTED BY THIS DOCUMENT. EXCEPT AS PROVIDED IN INTEL'S TERMS AND CONDITIONS OF SALE FOR SUCH PRODUCTS, INTEL ASSUMES NO LIABILITY WHATSOEVER, AND INTEL DISCLAIMS ANY EXPRESS OR IMPLIED WARRANTY, RELATING TO SALE AND/OR USE OF INTEL PRODUCTS INCLUDING LIABILITY OR WARRANTIES RELATING TO FITNESS FOR A PARTICULAR PURPOSE, MERCHANTABILITY, OR INFRINGEMENT OF ANY PATENT, COPYRIGHT OR OTHER INTELLECTUAL PROPERTY RIGHT. Intel products are not intended for use in medical, life saving, life sustaining, critical control or safety systems, or in nuclear facility applications.

Intel may make changes to specifications and product descriptions at any time, without notice.

Designers must not rely on the absence or characteristics of any features or instructions marked "reserved" or "undefined." Intel reserves these for future definition and shall have no responsibility whatsoever for conflicts or incompatibilities arising from future changes to them.

The Intel® RAID Controller SRCASJV may contain design defects or errors known as errata which may cause the product to deviate from published specifications. Current characterized errata are available on request.

Intel is a trademark or registered trademark of Intel Corporation or its subsidiaries in the United States and other countries.

*Other names and brands may be claimed as the property of others.

Copyright © 2007, Intel Corporation, Portions Copyright LSI Logic, Inc.

Table of Contents

1. Introduction	1
1.1 Product Overview	1
1.2 Operating System Support	1
1.3 Features List	2
2. Hardware	3
2.1 Block Diagram	3
2.2 Controller Layout	4
2.3 Major Components	4
2.3.1 LSI Logic 1078 SAS ROC	4
2.3.2 Flash ROM	5
2.3.3 Boot Strap ROM (SEEPROM)	5
2.3.4 NVSRAM	5
2.3.5 SDRAM (Cache)	5
2.3.6 Diagnostics	7
2.3.7 Jumpers and Controllers	10
2.4 Hardware Architectural Features	11
2.5 Electrical Characteristics	12
2.6 Environmental Specifications	12
2.7 Supported Device Technology	13
2.7.1 Support for Hard Disk Drive Devices	13
2.7.2 SAS Expander Support	13
2.7.3 Support for Non Hard Disk Drive Devices	13
2.7.4 Enclosure Management Support	13
3. Software	14
3.1 Common Layers	15
3.1.1 Firmware	15
3.1.2 API	15
3.1.3 Operating System Driver	16
3.2 User Interface	16
3.2.1 Intel® RAID BIOS Console 2 Configuration Utility	16
3.2.2 Intel® RAID Web Console 2	17
3.3 Command Line Utility	18

3.4	Flash Utility	18
3.5	SNMP Support.....	18
4.	RAID Functionality and Features	19
4.1	Hierarchy	19
4.1.1	Physical Drive Status	19
4.1.2	Virtual Drive Status	20
4.1.3	Drive Limitations	20
4.2	SAS Bus and ID Mapping	20
4.3	RAID Features	20
4.3.1	RAID Level Support	20
4.3.2	Cache Policies	21
4.3.3	Stripe Size	22
4.3.4	Hot Spare Drives	22
4.3.5	Hot-Plug Drive Support.....	22
4.3.6	Auto-declare Hot Spare Drive	22
4.3.7	Physical Drive Roaming.....	22
4.3.8	Virtual Drive Roaming.....	22
4.3.9	RAID Controller Migration.....	23
4.3.10	Online Capacity Expansion.....	23
4.3.11	RAID-Level Migration.....	23
4.4	Operating Certifications	23
5.	Safety and Regulatory Certifications.....	24
5.1	Product Safety Compliance	24
5.2	Product EMC Compliance – Class A Compliance	24
5.3	Certifications / Registrations / Declarations	24
5.4	Supported Specifications and Standards.....	25
Appendix A: Event Messages and Error Codes.....		26
Appendix B: Glossary		33
Appendix C: Reference Documents.....		34

List of Figures

Figure 1. Hardware Block Diagram	3
Figure 2. Intel® RAID Controller SRCASJV Physical Layout	4
Figure 3. Intel® RAID Smart Battery AXXRSBBU3	6
Figure 3. Intel® RAID Portable Cache Module AXXRPCM3	6
Figure 5. SAS/SATA Connectors	8
Figure 6. SFF8087 to Four-port Internal Cable	9
Figure 7. Jumpers and Controllers	11
Figure 8. Software Block Diagram	14

List of Tables

Table 1: Supported NVSRAM devices	5
Table 2. SFF8087 Connector Pin-out	8
Table 3. SFF8088 External Connector Pinout	10
Table 4. Hardware Architectural Feature	11
Table 5. Electrical Characteristics	12
Table 6. Environmental Specifications	12
Table 7. Storage and Transit Specifications	13
Table 8. Intel® RAID BIOS Console 2 Configuration Utility Options	16
Table 9. Intel® RAID Web Console 2 Options	17
Table 10. Command Line Utility Options	18
Table 11. RAID Physical Drive Status	19
Table 12. RAID Virtual Drive Status	20
Table 13. Supported RAID Levels	20
Table 14. Cache Policies	21
Table 15. Specifications and Standards	25

< This page intentionally left blank. >

1. Introduction

This document provides a detailed description of the Intel® RAID Controller SRCASJV and the software that supports it.

1.1 Product Overview

The Intel® RAID Controller SRCASJV supports both enterprise-class serial ATA (SATA) and serial-attached SCSI (SAS) disk drives. Supporting dual architectures allows solutions to be customized for performance, reliability, system expansion flexibility, and hard drive capacity. The RAID Controller SRCASJV provides flexibility and helps lower the total cost of ownership with a standardized server and storage infrastructure.

The RAID controller uses a x8 or wider PCI Express* server board slot and has eight SAS/SATA ports through two (x4 SAS port) SFF8088 Mini SAS 4i external connectors and two (x4 SAS Port) SFF8087 Mini SAS 4i internal connectors. The connectors can be configured through a SAS mux.

1.2 Operating System Support

The following operating systems are fully validated and supported at product launch. The latest service pack/update available at start of the test run will be tested:

- Microsoft Windows Server 2003* 32-bit
- Microsoft Windows Server 2003 64-bit Edition
- Red Hat* Linux 3.0 32-bit
- Red Hat Linux 3.0 64-bit Edition
- Red Hat Linux 4.0 32-bit
- Red Hat Linux 4.0 64-bit Edition
- SuSE* Linux Enterprise Server 9 32-bit
- SuSE Linux Enterprise Server 9 64-bit Edition
- SuSE Linux Enterprise Server 10 32-bit
- SuSE Linux Enterprise Server 10 64-bit Edition

The following operating systems will be tested with a baseline installation of the operating system. The latest service pack/update available at start of the test run will be tested.

- Microsoft Windows 2000* Server
- Microsoft Windows XP* 32-bit
- Microsoft Windows XP x64

These operating systems will be validated as a baseline operating system installation post launch:

- Novell* NetWare 6.5 32-bit
- Novell NetWare 6.5 x86-64

1.3 Features List

- Supports SAS/SATA devices at speeds up to 300 MB/second per port
- Supports the SATA II protocol over SAS transport
- Contains eight flexible ports configurable as internal or external SAS/SATA ports
- Supports up to 240 SAS/SATA II devices via expanders
- Supports up to 64 virtual disks
- Supports up to 128 arrays
- Supports RAID levels 0, 1, 5, 6, 10, 50, and 60
- Online capacity expansion
- Online RAID level migration
- Physical drive roaming
- RAID controller migration
- Fast virtual drive initialization
- Hot-spare drive configuration, both private and global
- SATA drive hot plug
- Staggered spin-up
- Native command queuing
- Auto rebuild
- Variable data stripe size configured per virtual drive
- 512 MB of ECC DDR2 Mini SDRAM on the controller
- Read and write cache policy
- SES2 intelligent enclosure support
- PCI hot plug support
- Background media test (patrol read)
- Background data integrity test

2. Hardware

2.1 Block Diagram

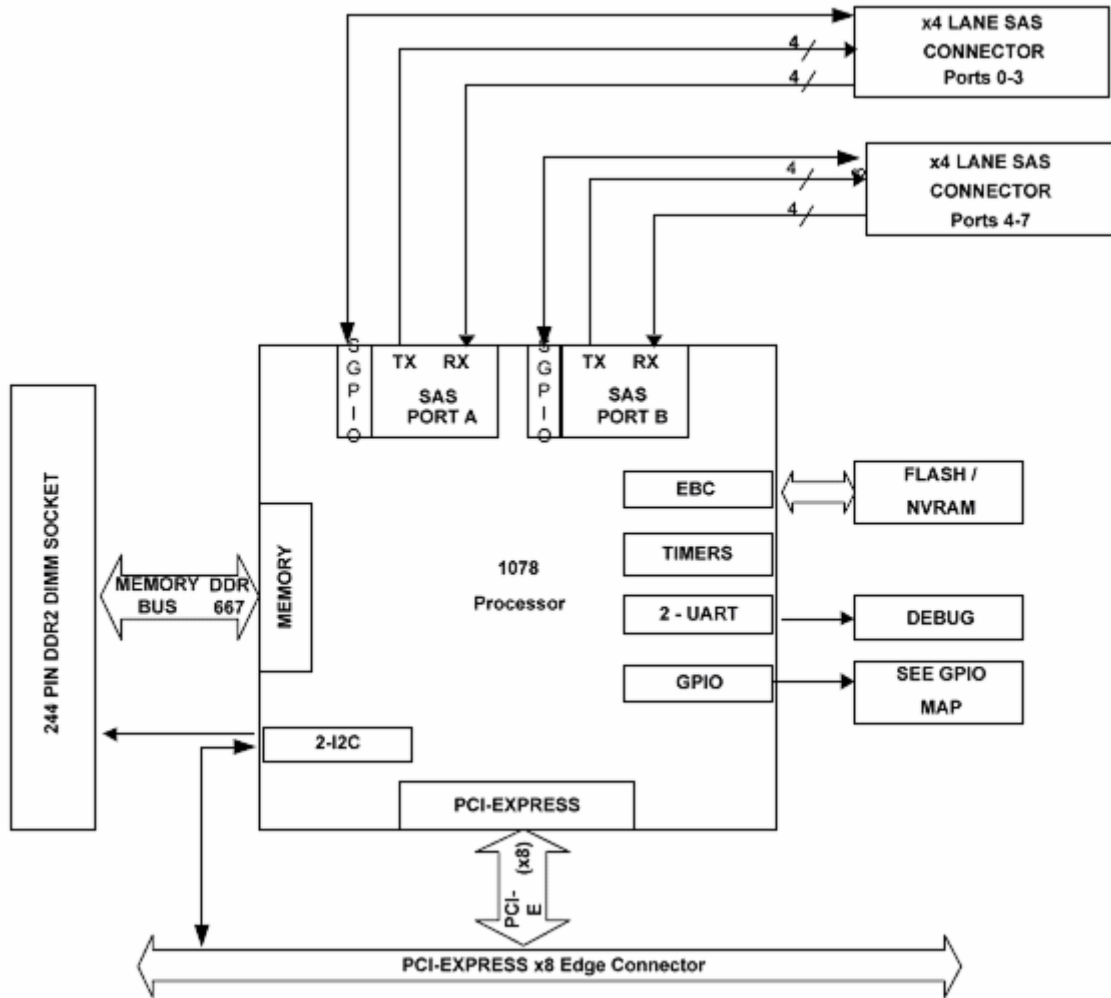

Figure 1. Hardware Block Diagram

2.2 Controller Layout

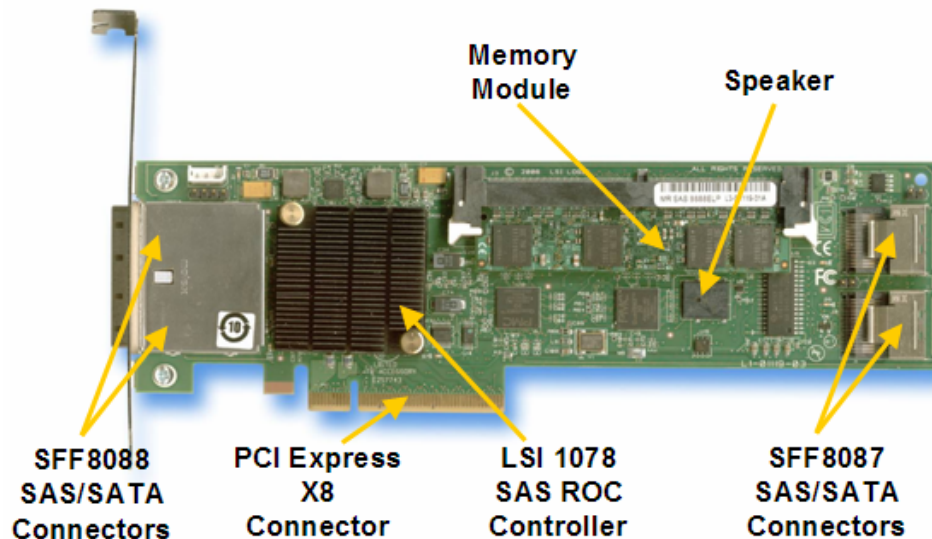

Figure 2. Intel® RAID Controller SRCASJV Physical Layout

2.3 Major Components

2.3.1 LSI Logic 1078 SAS ROC

The LSI Logic* 1078 SAS ROC is an integrated SAS and I/O controller with an embedded Power PC* 440 core running at 500 MHz. For information, see <http://www.lsillogic.com/>. The 1078 SAS ROC provides this functionality:

- PCI-Express* x8 interface.
- Local 72-bit DDR-II SDRAM interface with ECC checking.
- Dual independent internal DMA controllers maximize parallel data movement operations between system memory and any peripheral/block on the processor local bus (PLB) including local external devices like Flash ROM, NVRAM etc.
- Two messaging units. Only one can be enabled per power on cycle:
 - Fusion MPT message unit
 - Proprietary / test message unit.
- Two I²C interfaces for memory detection and PCI Express* SMBus connectivity. Serial boot-strap ROM is also connected here.
- Integrated dual UART for diagnostic use only.
- Eight channels of 3 Gbps full duplex SAS / SATA / tunneled SATA
- Two banks of SGPIO signals to accompany the two sets of x4 SAS/SATA ports
- PCI Express interface supports x8, x4, and x1 lane configurations

2.3.2 Flash ROM

The Intel® Advanced+ Book Block Flash Memory (C3) device is a 4 MB FLASH ROM configured for 16-bit I/O, manufactured on Intel's latest 0.13 µm and 0.18 µm technologies. This is a feature-rich solution for low-power applications. This device incorporates low-voltage capability (3 V read, program, and erase) with high-speed, low-power operation. Flexible block-locking allows any block to be independently locked or unlocked. For more information, see the Intel® Flash Memory website at <http://www.intel.com/design/flash>.

2.3.3 Boot Strap ROM (SEEPROM)

The serial bootstrap ROM is used to configure the 1078 before the server board configures the PCI Express* registers. The bootstrap ROM sets the PLL (Phase Lock Loop) dividers, external memory bus speed, etc.

2.3.4 NVSRAM

A 32 KB NVSRAM stores board and disk drive set up configurations.

Table 1. Supported NVSRAM devices

Device	Manufacturer	Configuration
STK14C88-3N35	SIMTEK	32Kbyte
STK14C88-3N45	SIMTEK	32Kbyte

2.3.5 SDRAM (Cache)

The Intel® RAID Controller SRCASJV includes a 512 MB DDR2 667 MHz ECC SDRAM Mini-DIMM. This DIMM is connected directly to the memory controller interface bus of the ROC and serves as storage for the executable code transferred from the flash. It also serves as cache during RAID transactions. Cache mode selection takes immediate effect while the server is online and is available on a per virtual drive basis. The ROC memory controller provides single-bit ECC error correction with multi-bit detection support.

The Intel® RAID Controller SRCASJV supports two options for battery backup support:

- The optional Intel® RAID Smart Battery AXRSBBU3 provides a battery backup option for data cached in the memory. The AXRSBBU3 does not mount directly to the controller. Instead, a supplied cable is used to connect the battery backup unit remotely to the RAID controller. See the following figure.



Figure 3. Intel® RAID Smart Battery AXXRSBBU3

- The optional Intel® RAID Portable Cache Module AXXRPCM3 ensures data integrity for the RAID solution by ensuring that the data passing through the cache is written to the hard drives. The AXXRPCM3 is compliant with the Smart Battery Data Specification, which relieves the host system from the responsibility of communicating battery information and charging the battery. Battery charging and recharging take place automatically. The AXXRPCM3 connects directly to the RAID controller in the Mini-DIMM socket. See the following figure.

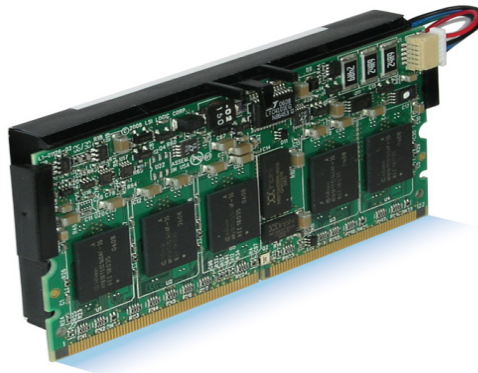

Figure 4. Intel® RAID Portable Cache Module AXXRPCM3

The Intel® RAID Smart Battery AXXRSBBU3 and the Intel® RAID Portable Cache Module AXXRPCM3 differ in that the Portable Cache Module AXXRPCM3 is implemented together with the DIMM and can be installed onto a new RAID card without compromising cache integrity.

Only one of these options can be used at a time. Attempting to install both the Smart Battery and the Portable Cache module may result in system errors.

2.3.6 Diagnostics

2.3.6.1 Audible Alarm

The audible alarm beeps if a drive fails and during a rebuild. The drive failure alarm beeps are:

- Degraded array: Short tone, one second on, one second off.
- Failed array: Long tone, three seconds on, one second off.
- Hot spare commissioned: Short tone, one second on, three seconds off.

The drive failure tones repeat until the problem is corrected, or until the alarm is silenced or disabled. The alarm can be silenced or disabled on the controller's properties page in the BIOS Console or by using the failed drive options pane in the Intel® RAID Web Console 2.

Silencing the alarm is temporary. If the cause of failure still exists or if an additional failure is detected, then the alarm sounds again when the system is rebooted. Disabling the alarm is persistent across errors and reboots. When the alarm is disabled, a failure does not cause it to sound until it is re-enabled.

The build alarm tone functions differently. It remains on during the rebuild. After the rebuild completes, an alarm with a different tone sounds to signal that the rebuild is complete. This is a one-time, non-repeating, tone.

2.3.6.2 LED Placement and Function

An LED is on the back of the controller near the battery connector signals when unwritten data remains in the cache when power is removed (dirty cache). Additional LED signaling is available through stake pin connectors on the controller.

2.3.6.3 SAS/SATA Connectors

The Intel® RAID Controller SRCASJV provides eight ports through two x4 SAS port SFF8088 Mini SAS 4i external connectors and two x4 SAS port SFF8087 Mini SAS 4i internal connectors. Each connector supports four SAS/SATA ports. Sideband signals are not used with this controller.

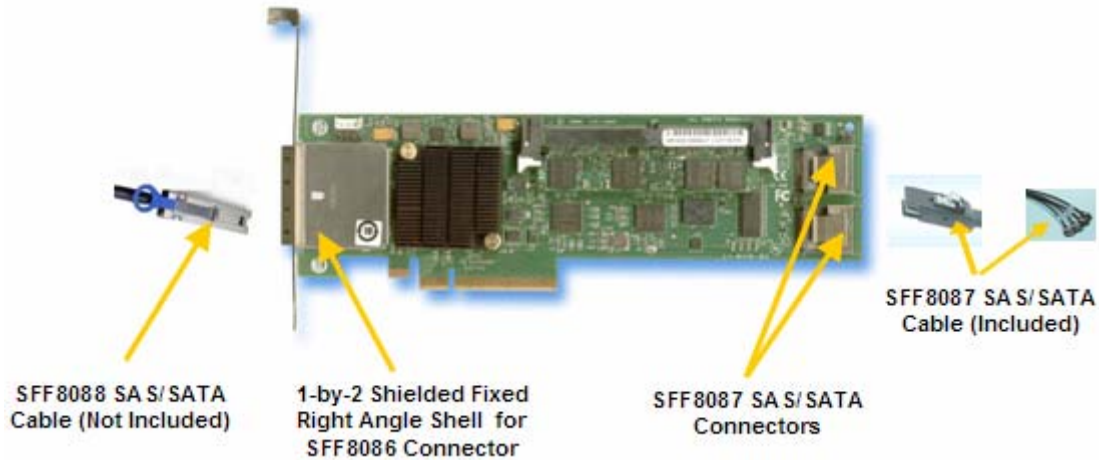

Figure 5. SAS/SATA Connectors

2.3.6.3.1 SAS/SATA Connector Pinout

Signal names are with respect to the host; the device connected to the host reverses the signal names. Transmit pins connect to receive pins on the other device. The SAS / SATA connector is keyed at pin 1. These pin-outs for the SAS / SATA connector are not compatible with the legacy PATA connector.

Table 2. SFF8087 Connector Pin-out

Controller Pinout		Backplane Pinout		Port
SFF8087	Pin Definition	SATA Connector	Pin Definition	
A1	GND	7	GND	Port 0
A2	RX0+	6	TX+	
A3	RX0-	5	TX-	
B1	GND	4	GND	
B2	TX0+	3	RX+	
B3	TX0-	2	RX-	
B4	GND	1	GND	
A4	GND	7	GND	Port 1
A5	RX1+	6	TX+	
A6	RX1-	5	TX-	
A7	GND	4	GND	
B5	TX1+	3	RX+	
B6	TX1-	2	RX-	
B7	GND	1	GND	
B8	Sideband 0			
B9	Sideband 1			
B10	Sideband 2			
A9	Sideband 3			
A10	Sideband 4			
A11	Sideband 5			

Controller Pinout		Backplane Pinout		Port
SFF8087	Pin Definition	SATA Connector	Pin Definition	
A8	Sideband 6			
B11	Sideband 7			
A12	GND	7	GND	Port 2
A13	RX2+	6	TX+	
A14	RX2-	5	TX-	
B12	GND	4	GND	
B13	TX2+	3	RX+	
B14	TX2-	2	RX-	
B15	GND	1	GND	
A15	GND	7	GND	
A16	RX3+	6	TX+	
A17	RX3-	5	TX-	
A18	GND	4	GND	
B16	TX3+	3	RX_	
B17	TX3-	2	RX-	
B18	GND	1	GND	

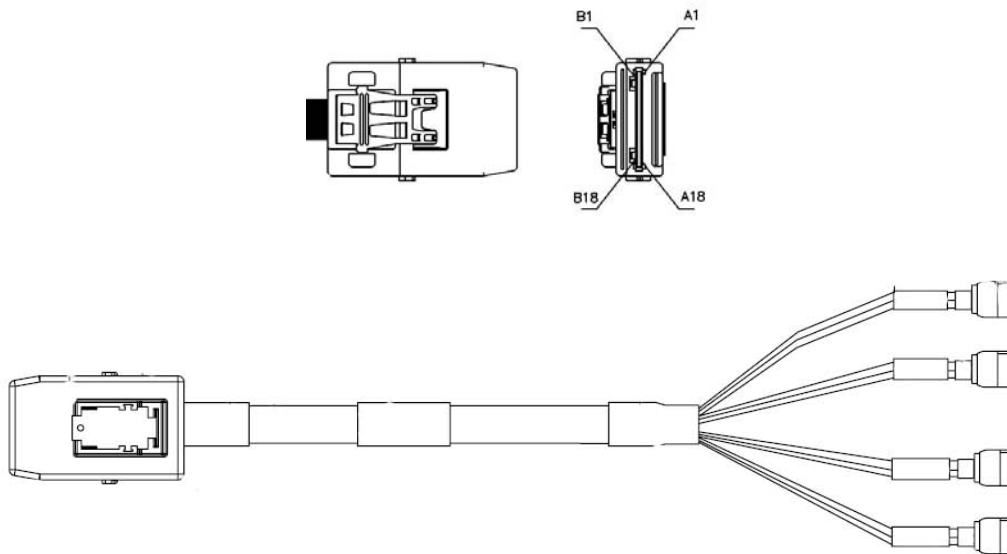

Figure 6. SFF8087 to Four-port Internal Cable

Table 3. SFF8088 External Connector Pinout

Signal	Pin	Signal	Pin
GND	A1	GND	B1
RX 0+	A2	TX 0+	B2
RX 0-	A3	TX 0-	B3
GND	A4	GND	B4
RX 1+	A5	TX 1+	B5
RX 1-	A6	TX 1-	B6
GND	A7	GND	B7
RX 2+	A8	RX 2+	B8
RX 2-	A9	RX 2-	B9
GND	A10	GND	B10
RX 3+	A11	RX 3+	B11
RX 3-	A12	RX 3-	B12
GND	A13	GND	B13

2.3.6.4 PCI Interface

The Intel® RAID Controller SRCSASJV must be installed into a x8 or larger PCI Express* slot. The controller is backward-compatible with x8 or larger slots that are wired with x1, x2 and x4 PCI Express lanes.

2.3.7 Jumpers and Controllers

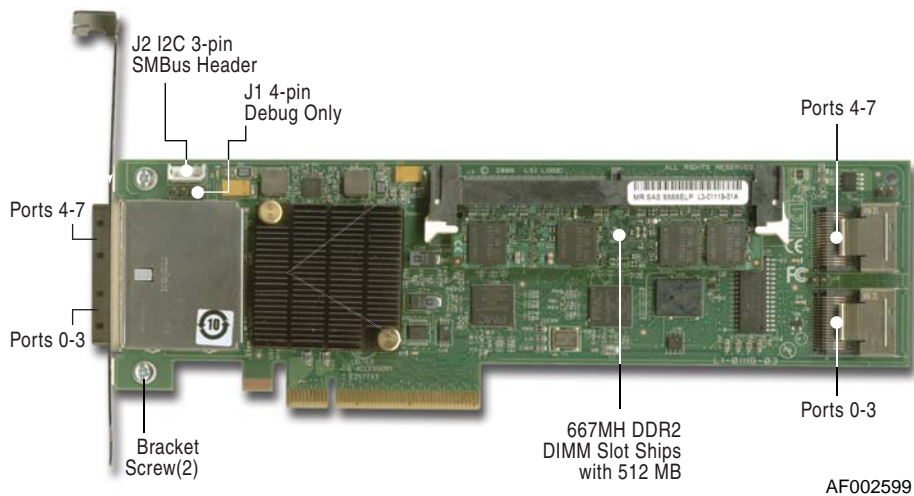

Jumper	Description	Type	Comments
J1	Universal Asynchronous Receiver/Transmitter (UART)	4-pin connector	For factory and debug use
J2	Keyed I ² C connector	3-pin keyed connector	Out-of-band enclosure management (SES2)

Jumper	Description	Type	Comments
J3	Mini-DIMM bracket		<p>Holds the cache memory module. The RAID controller supports these battery-backed cache configurations:</p> <ul style="list-style-type: none"> ▪ 256 MB: 72 b arrangement. Three 64 M x 16, Double Data Rate II at 667 MHz SDRAM intelligent transportable battery-backed mini-DIMM module ▪ 512 MB: 72 b arrangement. Three 128 M x 16, Double Data Rate II at 667 MHz SDRAM intelligent transportable battery-backed mini-DIMM module <p>Your limited warranty may be voided if you use unapproved memory modules.</p>
J6	Internal SAS/SATA port connector, ports 4-7	SFF8087	Connection to SAS/SATA devices.
J7	Internal SAS/SATA port connector, ports 0-3	SFF8087	Connection to SAS/SATA devices.
J8	Straps Default Boot Straps Controller	2-pin connector	Loads the defaults in case the boot strap controller (the serial ROM that controls the memory and processor speeds) becomes corrupt.
J9	Dirty Cache LED Header	2-pin connector	For connection to enclosure LED. When lit, it indicates the data in the cache has not been written to disk.
J10	Board-to-board connector for battery backup unit	20-pin connector	Provides an interface to the battery backup unit.

Figure 7. Jumpers and Controllers

2.4 Hardware Architectural Features

Table 4. Hardware Architectural Feature

Feature	Intel® RAID Controller SRCASJV
RAID levels	0, 1, 5, 6, 10, 50, 60
Number of devices	Up to 240 devices per controller
Device types	SAS and SATA hard drives
Data transfer rate	300 MB/s per port
PCI bus	x8 PCI Express*
Memory	512 MB ECC DDR2 667MHz SDRAM MiniDIMM
Battery backup (optional)	Intel® RAID Smart Battery AXRSBBU3 Intel® RAID Portable Cache Module AXRPCM3
SAS connector	Two x4 SAS Port SFF8088 Mini SAS 4i external connectors and two x4 SAS Port SFF8087 Mini SAS 4i internal connectors
ROC	LSI* 1078 SAS ROC, which performs hardware exclusive OR (XOR) assistance
Card dimensions	8.25 inches by 2.525 inches
Serial port	4-pin serial debug (requires transceiver)

Feature	Intel® RAID Controller SRCASJV
Compatible devices	240 physical devices, 64 logical drive, mixed capacity, SAS and SATA hard drives; non-disk devices including expanders.
Firmware	4 Mbit in flash ROM

2.5 Electrical Characteristics

All power is supplied to the Intel® RAID Controller SRCASJV through the PCI Express 3.3V and 12V rails. Onboard switching regulator circuitry operating from the 12V and the 3.3V rails provide the necessary voltages. The following states determine the typical current consumption of the controller:

- State 1: During a hard reset
- State 2: During a disk stress test
- State 3: While sitting idle at the DOS prompt

The supply voltages are 12 V \pm 8 percent from PCI edge connector only, and 3.3 V \pm 9 percent from PCI edge connector only. Table 5 lists the power supply for the RAID controller for each of the three states at the different voltages.

Table 5. Electrical Characteristics

	PCI Express* +12V	PCI Express +3.3V	PCI Express +3.3V auxiliary supply	PCI Power
State 1	1.00A	330 mA	30 mA	
State 2	1.81A	330 mA	30 mA	
State 3	1.53A	330 mA	30 mA	

The voltage level used in the charging circuitry for the battery pack on the optional Intel® RAID Smart Battery AXXRSBBU3 is +12 V. During fast charging of the battery pack, expected power consumption is 200 mA.

2.6 Environmental Specifications

Table 6. Environmental Specifications

Specifacaton	Description
Operating temperature	0 degrees Centigrade to 55 degrees Centigrade. (The maximum operating temperature decreases to +45 degrees Centigrade when the Intel® RAID Smart Battery AXXRSBBU3 is installed)
Relative humidity range	5% to 90% noncondensing
Maximum dew point temperature	32 degrees Centigrade
Airflow	200 linear feet per minute (LFPM)
MTBF (Electrical Components)	485,749 hours at 40 degrees Celsius

Table 7. Storage and Transit Specifications

Specification	Description
Temperature range without battery	-30 degrees Centigrade to +80 degrees Centigrade (dry bulb)
Temperature range with battery	0 degrees Centigrade to 45 degrees Centigrade (dry bulb)
Relative humidity range	5% to 90 % noncondensing

2.6.1.1 Safety Characteristics

The Intel® RAID Controller SRCSASJV meets or exceeds the requirements of UL flammability rating 94 V0. Each bare board is marked with the UL flammability rating. For boards installed in a PCI bus slot, all voltages are lower than the SELV 42.4 V limit.

2.7 Supported Device Technology

2.7.1 Support for Hard Disk Drive Devices

The Intel® RAID Controller SRCSASJV integrates eight internal high-performance SAS/SATA ports that provide support for SAS and enterprise-class SATA hard drives. Each port supports for both SAS and SATA devices using the SAS Serial SCSI Protocol (SSP), Serial Management Protocol (SMP), and Serial Tunneling Protocol (STP). The SSP protocol enables communication with other SAS devices. STP allows the SAS RAID controller to communicate with SATA devices via SATA commands.

2.7.2 SAS Expander Support

The RAID Controller SRCSASJV supports LSI Logic expanders and Vitesse SAS expanders that are used as a component in Intel enclosures. Other expanders may be supported post launch, based on market conditions and customer requirements.

2.7.3 Support for Non Hard Disk Drive Devices

Because SAS-based non hard drive devices were not available at the time of development of this controller, support for these devices will be determined as they become available. For information about support for non-hard drive devices, see the *Intel® RAID Controller SRCSASJV Tested Hardware and Operating System List*.

2.7.4 Enclosure Management Support

The Intel® RAID Controller SRCSASJV supports SES2 enclosure management in-band to expander-based backplanes and out-of-band to direct-connect backplanes.

3. Software

The SAS Software Stack and is planned for use with the current SAS RAID controllers and future RAID controllers that are compatible with SAS and SATA technology. This software stack includes software pieces used in RAID controller firmware, RAID controller BIOS, and RAID controller drivers and utilities. The graphic shows the inter-relationship of these software pieces.

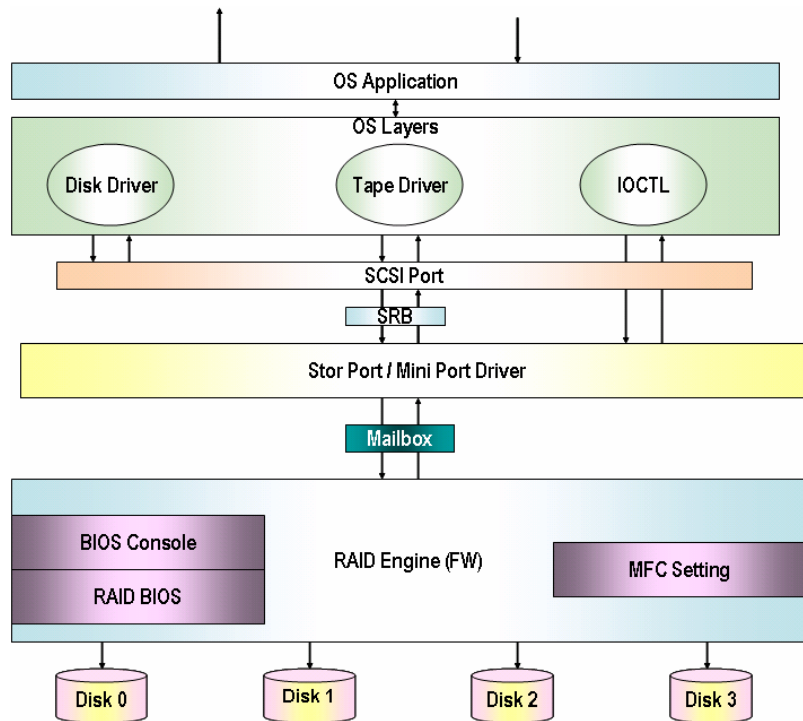

Figure 8. Software Block Diagram

3.1 Common Layers

3.1.1 Firmware

The firmware is composed of multiple software layers, allowing for maximum flexibility, reuse, and maintainability. These layers are described below.

3.1.1.1 MFC Settings

MFC default settings are factory programmed and consist of two types of settings:

- Settings that cannot be modified in the field. These include the PCI IDs.
- Settings that can be modified using a utility. These include default cache settings, rebuild rates, and other BIOS and operational defaults. Access to the MFC modification utility is restricted.

Additional information on MFC definitions and default settings is available upon request.

3.1.1.2 RAID BIOS

The RAID BIOS is the expansion ROM software defined in the PCI specification. It performs the RAID controller initialization from host system memory during POST.

3.1.1.3 Intel® RAID BIOS Console Configuration Utility

The Intel® RAID BIOS Console Configuration utility provides a graphical user interface to manage all aspects of the RAID subsystem and many features of the RAID controller. The utility is accessed by pressing the <Ctrl> + <G> keys during system boot time. See the *Intel® RAID Software User's Guide* (document number D29305-00x) for details about this utility.

3.1.1.4 RAID Firmware Engine

The RAID firmware contains the algorithms for mapping physical to virtual devices, RAID level algorithms, data redundancy calculation algorithms, and error detection, logging, and reporting capabilities.

3.1.2 API

To configure the Intel® RAID Controller SRCASJV, a set of interfaces known as the IOCTL interface allows an application to issue commands to the controller through the driver. Commands can be issued to determine adapter properties and change the parameter settings. The API package defines a higher level of commands and functions for developers who want to configure the RAID adapters with their own utility. This is implemented as a 32-bit dynamic link library (DLL) for Windows* operating systems and through a set of binaries for other operating systems. Access to the API libraries is restricted.

3.1.3 Operating System Driver

The operating system driver communicates between the host resident application and the RAID controller using specific communications protocol.

3.2 User Interface

3.2.1 Intel® RAID BIOS Console 2 Configuration Utility

The Intel® RAID BIOS Console 2 configuration utility is an X-ROM based utility that is accessed by pressing the <Ctrl> + <G> keys during POST. This utility usually starts at the completion of POST, but it may expand and operate during POST if sufficient PMM memory is available.

This utility is GUI-based that is most easily used with a mouse. The utility enables the user to easily configure the RAID controller properties, manage physical devices attached to the RAID controller, create and manage virtual drives, and manage the battery backup module. The RAID BIOS Console 2 configuration utility includes a configuration wizard that simplifies the process of creating disk arrays and virtual drives. The table below describes the available options.

Table 8. Intel® RAID BIOS Console 2 Configuration Utility Options

Option	Description
Adapter Properties	When you select the Adapter Selection option on the Main screen, the Intel® RAID BIOS Console 2 displays a list of the Intel® RAID adapters in the system. The Adapter Properties screen allows you to view and configure the software and hardware of the selected adapter.
Scan Devices	When you select the Scan Devices option on the Main screen, the Intel® RAID BIOS Console 2 checks the physical and virtual drives for any changes of the drive status. The RAID BIOS Console 2 displays the results of the scan in the physical and virtual drive descriptions.
Virtual Disks	The Virtual Disks screen provides options to Fast Initialize or Slow Initialize Virtual Disk, Check Consistency, Display Virtual Disk properties, and Set Boot Drive as specified virtual disk. Caution: Initializing a virtual drive deletes all information on the physical drives that compose the virtual drive.
Physical Drives	This screen displays the physical drives for each port. From this screen, you can rebuild the physical arrays or view the properties for the physical drive you select.
Configuration Wizard	This option enables you to clear a configuration, create a new configuration, or add a configuration.
Adapter Selection	This option allows you to choose an Intel RAID adapter installed in the system.
Physical view	This option toggles between Physical View and Virtual View.
Events	This option displays the events generated by virtual disks, physical devices, enclosure, the Intel® RAID Smart Battery AXRSBBU3 or the Intel® RAID Portable Cache Module AXRPCM3, and the SAS controller.

3.2.2 Intel® RAID Web Console 2

The Intel® RAID Web Console 2 utility runs within the operating system. It is Java* GUI-based that enables the user to configure the RAID controller, disk drives, Intel® RAID Smart Battery, and other storage related devices connected to the RAID controller or embedded on the server board.

The utility is used the most easily with a mouse, and standard right and left mouse clicks are functional based on the operating system mouse configuration.

The RAID Web Console 2 includes a Configuration Wizard that simplifies the process of creating disk arrays and virtual drives. Within the Configuration Wizard, the user can select from several options:

- Auto Configuration mode automatically creates the best possible configuration based on options configurable with available hardware.
- Guided Configuration mode asks brief questions about the configuration, and then creates the configuration based on the answers provided.
- Manual Configuration mode provides complete control over all aspects of the storage configuration.

A Reconstruction Wizard increases or reduces the size of a virtual disk and changes the RAID level of an array.

The table below briefly describes the available options. See the *Intel® RAID Software User's Guide* (document number D29305-00x) for detail description of these functions.

Table 9. Intel® RAID Web Console 2 Options

Option	Description
Menu Bar	Provides specific menu options including exit, rescan, operations, log and online help.
Physical / Virtual View Panel	Shows the hierarchy of physical / virtual devices in the server.
Properties / Operations / Graphical View Panel	Displays information about the selected device and the operations that can be performed on the selected device.
Event Log Panel	Displays the event log entries for the selected RAID controller.
Adapter Properties	Configure adapter properties. The configuration of these properties within the Intel® RAID Web Console 2 is limited to those properties that can be performed without a reboot of the controller or that are not data destructive.
Physical Drive Properties	View physical drive properties including drive model, serial number, defect tables, and association with virtual drives.
Virtual Disk Properties	View virtual disk properties including drive size, stripe size, disk cache policy, array cache policy, virtual disk name and status.
Configuration Wizard	Clear a configuration, create a new configuration, or add a configuration.

3.3 Command Line Utility

The command line utility (CLU) is an operating system-based text utility that allows the configuration of the RAID controller properties, configuration of disk arrays and virtual drives, configuration of cache settings, firmware update, and error reporting. The CLU is available upon request for DOS*, Windows*, and Linux* operating systems. For a list of all command line options see the *Command-Line User Guide*.

Table 10. Command Line Utility Options

Option	Description
Help	Command-line tool option to command help.
Controller Information	Provides information about controller properties and configuration.
Configuration information	Provides information on physical and virtual drives attached to the controller.
Configuration management	Allows configuration of the RAID controller, virtual drive properties, and hard drive cache configuration.
Configuration creation/deletion	Allows configuration or deletion of virtual drives including RAID level configuration, cache policy configuration, and hot spare configuration.

3.4 Flash Utility

This utility is an operating system based utility that allows you to update RAID controller firmware. It is available for DOS*, Microsoft Windows*, and Linux*. It is designed for use with a separate firmware update file. For a complete list of options, see the utility version release notes.

3.5 SNMP Support

SNMP support includes MIB files that are available upon request for recompilation compatibility with existing SNMP-enabled monitoring applications. An SNMP agent is also available. For operational details see the release notes that accompany these files.

4. RAID Functionality and Features

4.1 Hierarchy

A fundamental purpose of a RAID system is to present a usable data storage medium (virtual drive) with some level of redundancy to a host operating system. The Intel RAID firmware is based on the concept of associating physical drives in arrays and then creating a virtual drive from that array that includes a functional RAID level. To create a virtual drive and present it to the host operating system, the RAID firmware typically follows these steps:

1. One or more physical drives are selected and associated as an array.
2. One or more arrays are associated and given a RAID level. This process creates a virtual drive and provides an option to initialize the virtual drive.
3. The RAID firmware presents the virtual drive to the operating system.

4.1.1 Physical Drive Status

Table 11. RAID Physical Drive Status

Drive State	Code	Description
Unconfigured Good	Unconfigured Good	The drive is functioning normally, but is not part of a configured virtual drive and is not a hot spare.
Online	ONLN	The drive is online, is part of a configured virtual drive, and is functioning normally.
Hot Spare	HOTSP	A physical disk that is configured as a hot spare.
Failed	FAILED	A physical disk that was originally configured as Online or Hot Spare, but on which the firmware detects unrecoverable error.
Rebuilding	REBUILD	A physical disk to which data is being written to restore full redundancy for a virtual disk.
Unconfigured Bad	Unconfigured Bad	A physical disk on which the firmware detects an unrecoverable error; the physical disk was Unconfigured Good or the physical disk could not be initialized.
Missing	Missing	A physical disk that was Online, but which has been removed from its location.
Offline	Offline	A physical disk that is part of a virtual disk but which has invalid data as far as the RAID configuration is concerned.
None	None	A physical disk with an unsupported flag set. An Unconfigured Good or Offline physical disk that has completed the prepare for removal operation.

4.1.2 Virtual Drive Status

Table 12. RAID Virtual Drive Status

Drive State	Code	Description
Optimal	Optimal	The drive operating system is good. All configured drives are online.
Degraded	Degraded	The drive operating condition is not optimal because one of the configured drives has failed or is offline.
Offline	Offline	The drive is not available to the operating system and is unusable.

4.1.3 Drive Limitations

Only drives complying with the SAS and SATA specification extensions are supported.

4.2 SAS Bus and ID Mapping

Devices on the SAS bus are persistently mapped, based on a SAS address.

4.3 RAID Features

4.3.1 RAID Level Support

Table 13. Supported RAID Levels

RAID Level	Description
RAID 0	Data is striped to one or more physical drives. If using more than one disk, each stripe is stored on the drives in a "round robin" fashion. RAID 0 includes no redundancy. If one hard disk fails, all data is lost.
RAID 1	Disk mirroring: all data is stored twice, making each drive the image of the other. Missing data on one drive can be recovered from data on the other drive. RAID 1 requires two drives for each mirrored array.
RAID 5	Data striping with parity: data is striped across the hard disks and the controller calculates redundancy data (parity information) that is also striped across the hard disks. Missing data is rebuilt from parity. RAID 5 requires a minimum of three drives in the array but can be expanded to the capacity of the controller.
RAID 6	Data striping with distributed parity across two disk: Data is striped across all disks in the array and two parity disks are used to provide protection against the failure of up to two physical disks. In each row of data blocks, two sets of parity data are stored
RAID 10	RAID 10 is accomplished by striping data across two or up to eight RAID 1 arrays. Missing data is rebuilt from redundant data stripes. RAID 10 requires a minimum of four drives. RAID 10 provides high data throughput rates.
RAID 50	RAID 50 is accomplished by striping data across two or up to eight RAID 5 arrays. Missing data is rebuilt from redundant data stripes. RAID 50 requires a minimum of six drives. RAID 50 provides high data throughput rates
RAID 60	RAID 60 is accomplished by striping data across two or up to eight RAID 6 arrays. Missing data is rebuilt from redundant data stripes. RAID 60 requires a minimum of eight drives. RAID 60 provides high fault tolerance.

4.3.2 Cache Policies

The RAID cache can temporarily store data so it can be more quickly accessed, or it can wait for the drive to be ready. The cache is available both on the RAID controller and on hard drives. The RAID controller read and write cache policy is set on a virtual drive level. This policy is set when the virtual drive is created, but it can be changed using the Intel® RAID BIOS Console 2 configuration utility, the command line utility, or the Intel® RAID Web Console 2 utility.

The user should not enable specific cache policies if the Intel® RAID Smart Battery is not installed. The drive cache is managed through a user-configurable RAID controller option, but the RAID controller battery does not protect data in the drive cache in the event of a power interruption. Exercise caution when enabling the drive cache.

Table 14. Cache Policies

Array Cache Policy	Cache Option	Description
Cache Policy	Direct I/O	When possible, no cache is involved for both reads and writes. The data transfers will be directly from host to disk and from disk to host.
	Cached I/O	All reads will first look at cache. If a cache hit occurs, the data will be read from cache; if not, the data will be read from disk and the read data will be buffered into cache. All writes to drive are also written to cache.
Read Policy	No Read Ahead	The controller does not use read-ahead.
	Read Ahead	Specifies that additional consecutive data stripes are read and buffered into cache.
	Adaptive Read Ahead	Specifies that the controller begins using read-ahead if the two most recent disk accesses occurred in sequential sectors.
Write Policy	Write Through	The controller sends a data transfer completion signal to the host after the disk subsystem receives all the data in a transaction and the data is successfully written to disk.
	Write Back	The controller sends a data transfer completions signal to the host when the controller cache receives all the data in a transaction and the data is then written to disk as the drive becomes available. If the 'Use Write Through for failed or missing battery' option is disabled, the Write Back mode will be enabled even if the battery backup unit is bad or missing.
Hard Drive Cache	Read and Write Cache	Memory located on the hard drive is use to cache data going to or coming from the drive. Enabling hard drive cache can result in a performance improvement but data held in drive cache is not protected by the RAID controller.

4.3.3 Stripe Size

The stripe size determines the size of each data stripe on each hard drive. The options are 8, 16, 32, 64, 128, 256, 512, and 1024 KB. The stripe size is set when the virtual drive is created. It cannot be changed without removing the virtual drive configuration and all data contained on the virtual drive.

4.3.4 Hot Spare Drives

Hot-spare drives are designated to automatically replace a failed drive. Hot-spare drives must be the same size or larger than the drives they may replace. They can be designated as a private hot-spare drive assigned to one virtual drive, or they may be a global hot-spare that is assigned to all virtual drives attached to the RAID controller. Hot-spare drives can be designated using the Intel® RAID BIOS Console 2 utility, the Intel® RAID Web Console 2 utility, or the command line utility.

4.3.5 Hot-Plug Drive Support

Hot-plug support allows hard drives to be inserted or removed without rebooting the system, as long as both the hard drive and server system backplane support hard drive hot-plug functions.

The RAID controller immediately recognizes when a drive is removed and sets the virtual status to “Missing” until an I/O to the drive fails. The drive status then changes to “Failed.”

A drive inserted into an attached intelligent enclosure is recognized as present. A drive inserted into an attached non-intelligent enclosure may require a bus scan before it is detected. A hot-plug of new drives is supported in both intelligent and non-intelligent enclosures.

4.3.6 Auto-declare Hot Spare Drive

If the RAID controller has a RAID array drive that is in a failed (degraded) state and the failed drive is removed and a new hard drive of the same size or larger is inserted into the same slot, the new drive is automatically marked as a hot spare drive and a rebuild begins. A bus scan may be required in a non-intelligent enclosure.

4.3.7 Physical Drive Roaming

Physical drive roaming allows the user to move drives to any port on the RAID controller without losing the configuration.

4.3.8 Virtual Drive Roaming

Virtual drive roaming allows the user to move a virtual drive from one controller to another system/controller without losing the configuration or data. All virtual drives attached to the RAID controller must be moved as a unit.

4.3.9 RAID Controller Migration

The RAID controller migration feature allows a defective RAID controller to be removed and replaced by a compatible RAID controller without a losing the configuration or data. To avoid a configuration mismatch, it is wise to reset the new controller configuration before attaching the array drives. If a configuration mismatch occurs, then care must be taken to use the configuration on the drives or all data may be lost.

4.3.10 Online Capacity Expansion

Online capacity expansion (OCE) allows additional drives to be added to a virtual drive in an array. OCE is available as an option in the Intel® BIOS Console 2 utility, the Intel® RAID Web Console 2 utility, or the command line utility.

4.3.11 RAID-Level Migration

RAID-level migration allows for the migration from one RAID level to another. RAID-level migration may require the addition of additional physical drives as part of the process. RAID-level migration is an option in the Intel® RAID BIOS Console 2 utility, the Intel® RAID Web Console 2 utility, or the command line utility.

4.4 Operating Certifications

Microsoft Windows* Winqual certification (WHQL).

5. Safety and Regulatory Certifications

5.1 Product Safety Compliance

- UL approval or acceptable NRTL (e.g. ETL) approval
- EN60950 (Europe)
- IEC60950 (International)
- CB Certificate & Report, IEC60950 (report to include all country national deviations)
- CE - Low Voltage Directive 73/23/EEE (Europe)

5.2 Product EMC Compliance - Class A Compliance

- FCC /ICES-003 - Emissions (USA/Canada) Verification
- CISPR 22 – Emissions (International)
- EN55022 - Emissions (Europe)
- EN55024 - Immunity (Europe)
- CE – EMC Directive 89/336/EEC (Europe)
- VCCI Emissions (Japan)
- AS/NZS 3548 Emissions (Australia / New Zealand)
- BSMI CNS13438 Emissions (Taiwan)
- RRL MIC Notice No. 1997-41 (EMC) & 1997-42 (EMI) (Korea)

5.3 Certifications / Registrations / Declarations

- CE Declaration of Conformity (CENELEC Europe)
- FCC/ICES-003 Class B Attestation (USA/Canada)
- C-Tick Declaration of Conformity (Australia)
- BSMI Certification (Taiwan)
- RRL Certification (Korea)

5.4 Supported Specifications and Standards

Table 15. Specifications and Standards

Standard	Description
SAS Specification 1.1	
Serial ATA specification 1.0a	
Extensions to Serial ATA specification 1.0a	
PCI Express Base Specification 1.0	
SAFTE	SCSI Accessed Fault-Tolerant enclosure management
SES	SCSI Enclosure Services (SES)
SSP	Serial SCSI Protocol (SSP) which maps in SCSI, supporting multiple initiators and targets
STP	Serial ATA Tunneled Protocol (STP) mapping Serial ATA, supporting multiple initiators and targets
SMP	Serial Management Protocol (SMP) a management protocol

Appendix A: Event Messages and Error Codes

This appendix lists the Intel® RAID Web Console 2 events that may appear in the event log.

The Intel® RAID Web Console 2 utility monitors the activity and performance of all controllers in the server and the devices attached to them. When an event occurs, such as the completion of a consistency check or the removal of a physical drive, an event message is displayed in the at the bottom of the Intel® RAID Web Console 2 screen. The message is also logged in the Windows Application Log (Event Viewer). Error event levels are:

- **PROGRESS:** This is a progress posting event. Progress events are not saved in NVRAM.
- **INFORMATION:** Informational message. No user action is necessary.
- **WARNING:** Some component may be close to a failure point
- **CRITICAL:** A component has failed, but the system has not lost data
- **FATAL:** A component has failed, and data loss has occurred or will occur
- **DEAD:** A catastrophic error has occurred and the controller has died. Seen only after the controller has been restarted.

The following table lists the Intel® RAID Web Console 2 event messages.

Number	Type	Description
0	Information	Firmware initialization started (PCI ID %04x/%04x/%04x/%04x)
1	Information	Firmware version %s
2	Fatal	Unable to recover cache data from TBBU
3	Information	Cache data recovered from TBBU successfully
4	Information	Configuration cleared
5	Warning	Cluster down; communication with peer lost
6	Information	%s ownership changed from %02x to %02x
7	Information	Alarm disabled by user
8	Information	Alarm enabled by user
9	Information	Background initialization rate changed to %d%%
10	Fatal	Controller cache discarded due to memory/battery problems
11	Fatal	Unable to recover cache data due to configuration mismatch
12	Information	Cache data recovered successfully
13	Fatal	Controller cache discarded due to firmware version incompatibility
14	Information	Consistency Check rate changed to %d%%
15	Dead	Fatal firmware error: %s
16	Information	Factory defaults restored A249
17	Warning	Flash downloaded image corrupt
18	Critical	Flash erase error
19	Critical	Flash timeout during erase
20	Critical	Flash error
21	Information	Flashing image: %s

Number	Type	Description
22	Information	Flash of new firmware image(s)complete
23	Critical	Flash programming error
24	Critical	Flash timeout during programming
25	Critical	Flash chip type unknown
26	Critical	Flash command set unknown
27	Critical	Flash verify failure
28	Information	Flush rate changed to %d seconds
29	Information	Hibernate command received from host
30	Information	Event log cleared
31	Information	Event log wrapped
32	Dead	Multi-bit ECC error: ECAR=%x
33	Warning	Single-bit ECC error: ECAR=%x
34	Dead	Not enough controller memory
35	Information	Patrol Read complete
36	Information	Patrol Read paused
37	Information	Patrol Read Rate changed to %d%%
38	Information	Patrol Read resumed
39	Information	Patrol Read started
40	Information	Rebuild rate changed to %d%%
41	Information	Reconstruction rate changed to %d%%
42	Information	Shutdown command received from host
43	Information	Test event: '%s'
44	Information	Time established as %s; (%d seconds since power on)
45	Information	User entered firmware debugger
46	Warning	Background Initialization aborted on %s
47	Information	Background Initialization corrected medium error (%s at %lx, %s at %lx)
48	Information	Background Initialization completed on %s
49	Fatal	Background Initialization completed with uncorrectable errors on %s
50	Fatal	Background Initialization detected uncorrectable multiple medium errors (%s at %lx on %s)
51	Critical	Background Initialization failed on %s
52	Progress	Background Initialization progress on %s is %s
53	Information	Background Initialization started on %s
54	Information	Policy change on %s to %s from %s
55		OBSOLETE
56	Information	Consistency Check aborted on %s
57	Information	Consistency Check corrected medium error (%s at %lx, %s at %lx)
58	Information	Consistency Check done on %s
59	Information	Consistency Check done with corrections on %s, (corrections=%d)
60	Fatal	Consistency Check detected uncorrectable multiple medium errors (%s at %lx on %s)
61	Critical	Consistency Check failed on %s
62	Fatal	Consistency Check failed with uncorrectable data on %s
63	Information	Consistency Check found inconsistent parity on %s at strip %lx
64	Warning	Consistency Check inconsistency logging disabled on %s (too many inconsistencies)
65	Progress	Consistency Check progress on %s is %s

Number	Type	Description
66	Information	Consistency Check started on %s
67	Information	Initialization aborted on %s
68	Critical	Initialization failed on %s
69	Progress	Initialization progress on %s is %s
70	Information	Fast initialization started on %s
71	Information	Full initialization started on %s
72	Information	Initialization complete on %s
73	Information	%s Properties updated to %s (from %s)
74	Information	Reconstruction complete on %s
75	Fatal	Reconstruction of %s stopped due to unrecoverable errors
76	Fatal	Reconstruct detected uncorrectable multiple medium errors (%s at %lx on %s at %lx)
77	Progress	Reconstruction progress on %s is %s
78	Information	Reconstruction resumed on %s
79	Fatal	Reconstruction resume of %s failed due to configuraiton mismatch
80	Information	Reconstruction started on %s
81	Information	State change on %s from %s to %s
82	Information	Clear aborted on %s
83	Critical	Clear failed on %s (Error %02x)
84	Progress	Clear progress on %s is %s
85	Information	Clear started on %s
86	Information	Clear completed on %s
87	Warning	Error on %s (Error %02x)
88	Information	Format complete on %s
89	Information	Format started on %s
90	Warning	Hot Spare SMART polling failed on %s (Error %02x)
91	Information	Inserted: %s
92	Warning	%s is not supported
93	Information	Patrol Read corrected medium error on %s at %lx
94	Progress	Patrol Read progress on %s is %s
95	Fatal	Patrol Read found an uncorrectable medium error on %s at %lx
96	Warning	Predictive failure: %s
97	Fatal	Puncturing bad block on %s at %lx
98	Information	Rebuild aborted by user on %s
99	Information	Rebuild complete on %s
100	Information	Rebuild complete on %s
101	Critical	Rebuild failed on %s due to source drive error
102	Critical	Rebuild failed on %s due to target drive error
103	Progress	Rebuild progress on %s is %s
104	Information	Rebuild resumed on %s
105	Information	Rebuild started on %s
106	Information	Rebuild automatically started on %s
107	Critical	Rebuild stopped on %s due to loss of cluster ownership
108	Fatal	Reassign write operaiton failed on %s at %lx
109	Fatal	Unrecoverable medium error during rebuild on %s at %lx

Number	Type	Description
110	Information	Corrected medium error during recovery on %s at %lx
111	Fatal	Unrecoverable medium error during recovery on %s at %lx
112	Warning	Removed: %s
113	Information	Unexpected sense: %s, CDB:%s, Sense:%s
114	Information	State change on %s from %s to %s
115	Information	State change by user on %s from %s to %s
116	Warning	Redundant path to %s broken
117	Information	Redundant path to %s restored
118	Information	Dedicated Hot Spare %s no longer useful due to deleted array
119	Critical	SAS topology error: Loop detected
120	Critical	SAS topology error: Unaddressable device
121	Critical	SAS topology error: Multiple ports to the same SAS address
122	Critical	SAS topology error: Expander error
123	Critical	SAS topology error: SMP timeout
124	Critical	SAS topology error: Out of route entries
125	Critical	SAS topology error: Index not found
126	Critical	SAS topology error: SMP function failed
127	Critical	SAS topology error: SMP CRC error
128	Critical	SAS topology error: Multiple subtractive
129	Critical	SAS topology error: Table to table
130	Critical	SAS topology error: Multiple paths
131	Fatal	Unable to access device %s
132	Information	Dedicated Hot Spare created on %s (%s)
133	Information	Dedicated Hot Spare %s (%s) disabled
134		
135	Information	Global Hot Spare created on %s (%s)
136	Information	Global Hot Spare %s (%s) disabled
137		
138	Information	Created %s
139	Information	Deleted %s
140	Information	Marking %s inconsistent due to active writes at shutdown
141	Information	Battery Present
142	Warning	Battery Not Present
143	Information	New Battery Detected
144	Information	Battery has been replaced
145	Warning	Battery temperature is high
146	Warning	Battery voltage low
147	Information	Battery started charging
148	Information	Battery is discharging
149	Information	Battery temperature is normal
150	Fatal	Battery needs replacement - SOH Bad
151	Information	Battery relearn started
152	Information	Battery relearn in progress
153	Information	Battery relearn completed

Number	Type	Description
154	Warning	Battery relearn timed out
155	Information	Battery relearn pending: Battery is under charge
156	Information	Battery relearn postponed
157	Information	Battery relearn will start in 4 days
158	Information	Battery relearn will start in 2 day
159	Information	Battery relearn will start in 1 day
160	Information	Battery relearn will start in 5 hours
161	Warning	Battery removed
162	Warning	Current capacity of the battery is below threshold
163	Information	Current capacity of the battery is above threshold
164	Information	Enclosure (SES) discovered on %s
165	Information	Enclosure (SAF-TE) discovered on %s
166	Critical	Enclosure %s communication lost
167	Information	Enclosure %s communication restored
168	Critical	Enclosure %s fan %d failed
169	Information	Enclosure %s fan %d inserted
170	Warning	Enclosure %s fan %d removed
171	Critical	Enclosure %s power supply %d failed
172	Information	Enclosure %s power supply %d inserted
173	Warning	Enclosure %s power supply %d removed
174	Critical	Enclosure %s EMM %d failed
175	Information	Enclosure %s EMM %d inserted
176	Critical	Enclosure %s EMM %d removed
177	Warning	Enclosure %s temperature sensor %d below warning threshold
178	Critical	Enclosure %s temperature sensor %d below error threshold
179	Warning	Enclosure %s temperature sensor %d above warning threshold
180	Critical	Enclosure %s temperature sensor %d above error threshold
181	Critical	Enclosure %s shutdown
182	Warning	Enclosure %s not supported; too many enclosures connected to port
183	Critical	Enclosure %s firmware mismatch (EMM %d)
184	Warning	Enclosure %s sensor %d bad
185	Critical	Enclosure %s phy bad for slot %d
186	Critical	Enclosure %s is unstable
187	Critical	Enclosure %s hardware error
188	Critical	Enclosure %s not responding
189	Warning	SAS/SATA mixing not supported in enclosure; %s disabled
190	Warning	Enclosure (SES) hotplug on %s was detected
191	Information	Clustering enabled
192	Information	Clustering disabled
193	Information	PD too small to be used for auto-rebuild on %s
194	Information	BBU enabled; changing WT virtual disks to WB
195	Warning	BBU disabled; changing WB virtual disks to WT
196	Warning	Bad block table on %s is 80% full
197	Fatal	Bad block table on %s is full; unable to log block %lx

Number	Type	Description
198	Information	Consistency Check Aborted Due to Ownership Loss on %s
199	Information	Background Initialization (BGI) Aborted Due to Ownership Loss on %s
200	Critical	Battery/charger problems detected; SOH Bad
201	Warning	Single-bit ECC error: ECAR=%x
202	Critical	Single-bit ECC error: ECAR=%x
203	Critical	Single-bit ECC error: ECAR=%x
204	Warning	Enclosure %s Power supply %d switched off
205	Information	Enclosure %s Power supply %d switched on
206	Warning	Enclosure %s Power supply %d cable removed
207	Information	Enclosure %s Power supply %d cable inserted
208	Information	Enclosure %s Fan %d returned to normal
209		
210	Information	BBU Retention test passed
211	Critical	BBU Retention test failed!
212		
213	Information	NVRAM Retention test passed
214	Critical	NVRAM Retention test failed!
215	Information	%s test completed %d passes successfully
216	Critical	%s test FAILED on %d pass. Fail data: errorOffset=%x goodData=%x badData=%x
217	Information	Self check diagnostics completed
218	Information	Foreign Configuration Detected
219	Information	Foreign Configuration Imported
220	Information	Foreign Configuration Cleared
221	Warning	NVRAM is corrupt; reinitializing
222	Warning	NVRAM mismatch occurred
223	Warning	SAS wide port %d lost link on PHY %d
224	Information	SAS wide port %d restored link on PHY %d
225	Warning	SAS port %d, PHY %d has exceeded the allowed error rate
226	Information	Bad block reassigned on %s at %lx to %lx
227	Information	Controller Hot Plug detected
228	Warning	Enclosure %s temperature sensor %d differential detected
229	Information	Disk test cannot start. No qualifying disks found
230	Information	Time duration provided by host is not sufficient for self check
231	Information	Marked Missing for %s on array %d row %d
232	Information	Replaced Missing as %s on array %d row %d
233	Information	Enclosure %s temperature sensor %d returned to normal
234	Information	Enclosure %s Firmware download in progress
235	Warning	Enclosure %s Firmware download failed
236	Warning	%s is not a certified drive
237	Information	Dirty cache data discarded by user
238	Warning	PDs missing from configuration at boot
239	Warning	VDs missing drives and will go offline at boot: %s
240	Warning	VDs missing at boot: %s
241	Warning	Previous configuration completely missing at boot

Number	Type	Description
242	Information	Battery charge complete
243	Information	Enclosure %s fan %d speed changed
244	Information	Dedicated spare %s imported as global due to missing arrays
245	Information	%s rebuild not possible as SAS/SATA is not supported in an array
246	Information	SEP %s has been rebooted as a part of enclosure firmware download. SEP will be unavailable until this process completes.
247	Information	Inserted: %s Info: %s
248	Information	Removed: %s Info: %s
249	Information	%s is now OPTIMAL
250	Warning	%s is now PARTIALLY DEGRADED
251	Critical	%s is now DEGRADED
252	Fatal	%s is now OFFLINE
253	Warning	Battery requires reconditioning; please initiate a LEARN cycle
254	Warning	VD %s disabled because RAID-5 is not supported by this RAID key
255	Warning	VD %s disabled because RAID-6 is not supported by this controller
256	Warning	VD %s disabled because SAS drives are not supported by this RAID key
257	Warning	PD missing: %s
258	Warning	Puncturing of LBAs enabled
259	Warning	Puncturing of LBAs disabled
260	Critical	Enclosure %s EMM %d not installed
261	Information	Package version %s
262	Warning	Global affinity Hot Spare %s commissioned in a different enclosure
263	Warning	Foreign configuration table overflow
264	Warning	Partial foreign configuration imported
265	Information	Connector %s is active
266	Information	Board Revision %s
267	Warning	Command timeout on %s
268	Warning	%s reset (Type %02x)
269	Warning	VD bad block table on %s is 80% full
270	Fatal	VD bad block table on %s is full; unable to log block %lx (on %s at %lx)
271	Fatal	Uncorrectable medium error logged for %s at %lx (on %s at %lx)
272	Information	VD medium error corrected on %s at %lx
273	Warning	Bad block table on %s is 100% full
274	Warning	VD bad block table on %s is 100% full

Appendix B: Glossary

Word / Acronym	Definition
API	Application Programming Interface
ECC	Error Correction Code
FUU	Flash Update Utility
FW	Firmware
Gb	Gigabit
GB	Gigabyte
HBA	Host Bus Adapter
Kb	Kilobit
KB	Kilobyte
LVD	Low Voltage Differential
Mb	Megabit
MB	Megabyte
PCB	Printed Circuit Board
PCI	Peripheral Component Interconnect
POST	Power On Self Test
RAID	Redundant Array of Independent Disks
SAF-TE	SCSI Accessed Fault Tolerant Enclosure, enclosure management that supports SCSI devices
SAS	Serial Attached SCSI
SCSI	Small Computer Systems Interface
SES2	SCSI Enclosure Services 2nd generation, enclosure management that supports SAS devices
SGPIO	Serial General Purpose Input Output, Enclosure management that supports SATA devices
SNMP	Simple Network Management Protocol
XROM	PCI Expansion ROM, a BIOS utility accessed at system POST.
POST	Power On Self Test

Appendix C: Reference Documents

- *Intel® RAID Controller SRCASJV Hardware User's Guide*, document number E16747-00x
- *Intel® RAID Software User's Guide*, document number D29305-00x
- *Intel® RAID Controller SRCASJV Command Line Tool User Guide*, Version 1.0.