

6 Install the Wind Tunnel

This illustration shows the installed locations and airflow directions for Wind Tunnel assemblies.

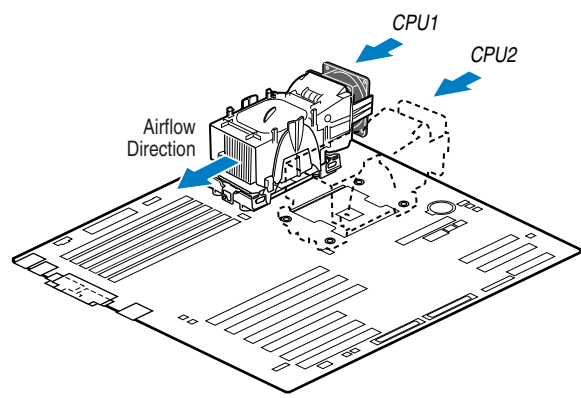

A. Attach the Fan Intake to the Wind Tunnel

- Hold the Fan Intake at approximately 45 degrees and engage the clip at top of Wind Tunnel as shown.
- Insert the tabs into the two mating slots on the Wind Tunnel.
- Rotate Fan Intake downward.
- Make sure Fan Intake snaps onto Wind Tunnel tabs.

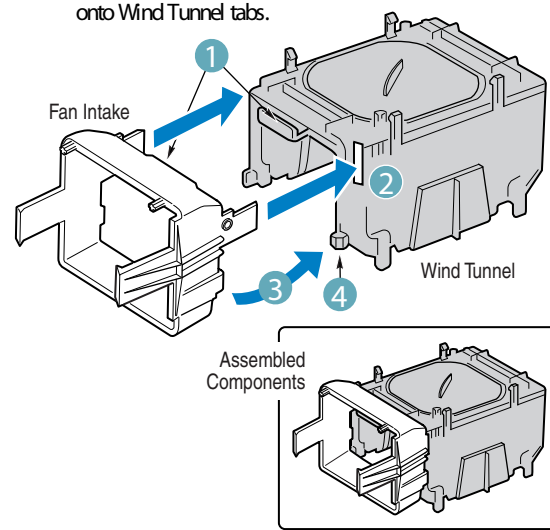

B. Attach the Fan

Note: Although the fan can be mounted at the top of the wind tunnel, for adequate DIMM cooling only the diagrammed installation below is recommended.

Insert one side of fan, then pull out slightly on the tab at the other side of the fan intake to insert the fan between the tabs. The fan label must face into the unit for the air to flow in the correct direction.

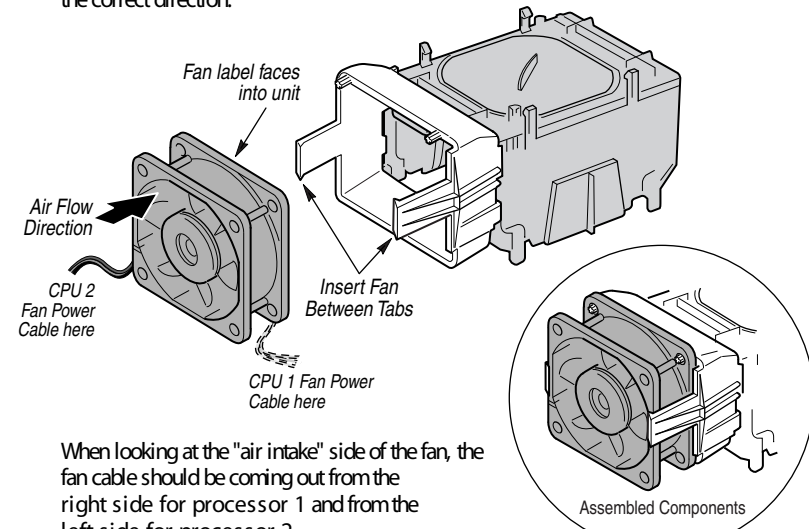

When looking at the "air intake" side of the fan, the fan cable should be coming out from the right side for processor 1 and from the left side for processor 2.

C. Attach the Wind Tunnel to the Processor Assembly

- Spread two Tabs outward slightly.
- Lower Wind Tunnel onto Retention Mechanism.
- Tabs on Tunnel mate to outside surface of Retention Mechanism.
- Ledge on Tunnel snaps into mating recess on Retention Mechanism.
- Correct assembly should look like this.

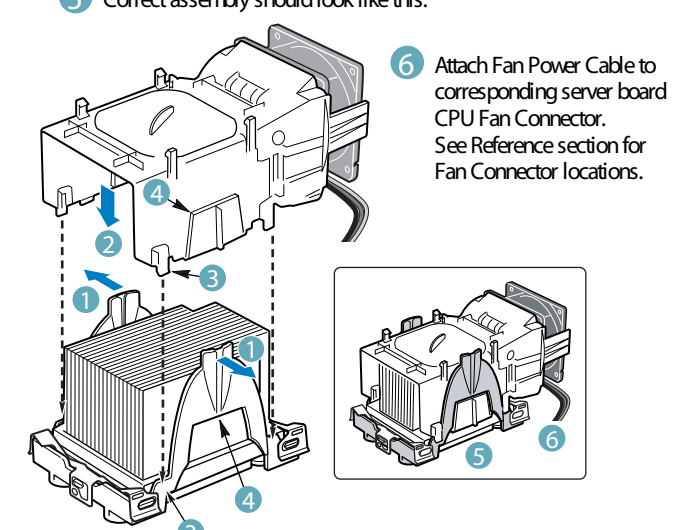

7 Install Memory

DIMM Memory Modules

Memory Type: Minimum of two identical 128MB ECC, DDR200/266-compliant registered SDRAM 184-pin gold DIMMs.

Notes and Cautions: DIMMs must be installed in pairs and must be populated starting with DIMM Bank 1 (contiguous sockets DIMM1A and DIMM1B). Although the server board architecture allows the user to mix various sizes of DIMMs between banks, DIMMs must be identical within each bank.

For example, Bank 1 can use two 128MB DIMMs and Bank 2 can use two 256MB DIMMs.

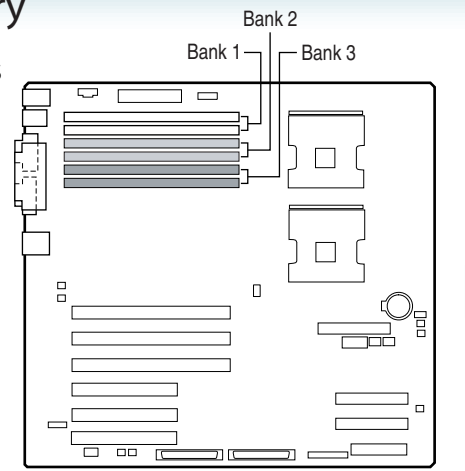

- Open both DIMM socket levers.
 - Note location of alignment notch.
 - Insert DIMM making sure the connector edge of the DIMM aligns correctly with the slot.
 - Check that socket levers are securely latched.
- Avoid touching gold contacts when handling or installing DIMMs.

8 Making Connections to the Server Board ... Quick Reference

Required Connections for Selected Chassis

	SC5200-Base	SC5200-BRP	SC5200-HSRP	SR1350-E
A. Auxiliary Signal Connector	⊘	■	■	⊘
B. Main Power Connector	■	■	■	■
C. +12V CPU Power Connector	■	■	■	■
I. Front Panel Connector	■	■	■	■

CPU/System Fan Connections for Selected Chassis

	SC5200-Base	SC5200-BRP	SC5200-HSRP	SR1350-E
D. CPU1 Fan Header [top]	■	■	■	■
... if CPU2 is installed	■	■	■	■
N. System Fan 1 Header [top]	■	■	■	■
H. System Fan 3 Header	■	■	■	■
F. System Fan 4 Header [bottom]	■	■	■	■
System Fan 5 Header [top]	⊘	⊘	■	■

* For the Intel® Server Chassis SR1350-E, connect chassis fan cable to the nearest available fan connector on the server board.

Optional Connections for Selected Chassis

	SC5200-Base	SC5200-BRP	SC5200-HSRP	SR1350-E
E. Floppy Connector	■	■	■	■
G. Front USB Connector	■	■	■	■
J. SCSI Connectors	■	■	■	■
K. Chassis Intrusion Header	■	■	■	■
L. Serial B Header	■	■	■	■
M. Primary IDE Connector [top, black connector]	■	■	■	■
Secondary IDE Connector [bottom, white connector]	■	■	■	■

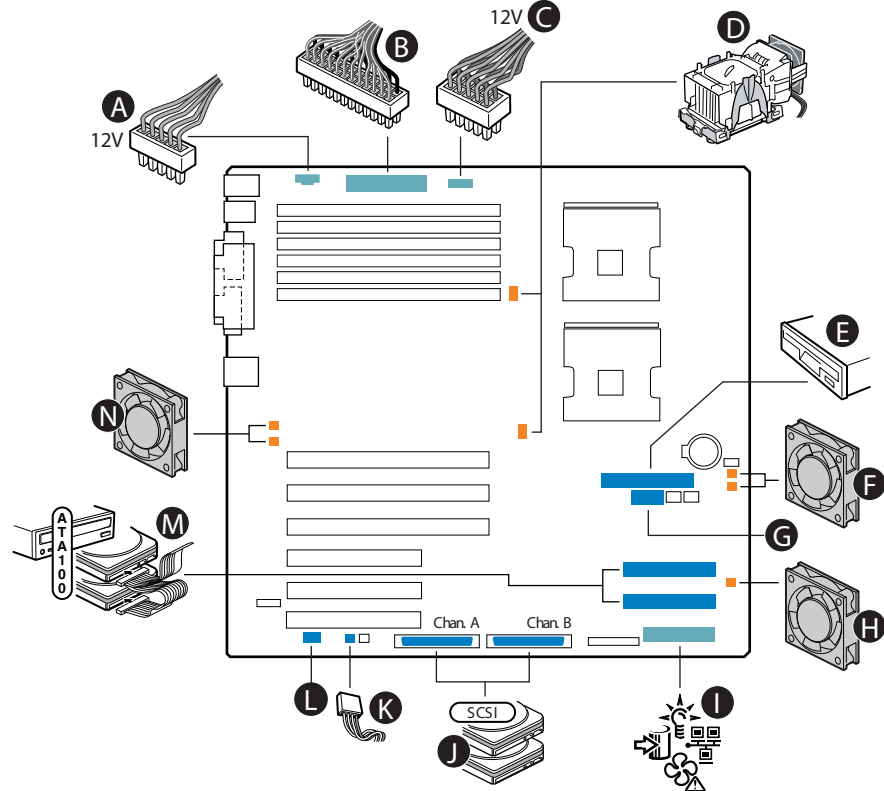

9 Install the Serial B Cable (optional)

For the Intel® Server Chassis SC5200, you can connect the Serial B cable to either the back of the chassis or, on a rack mount system, to the front of the chassis.

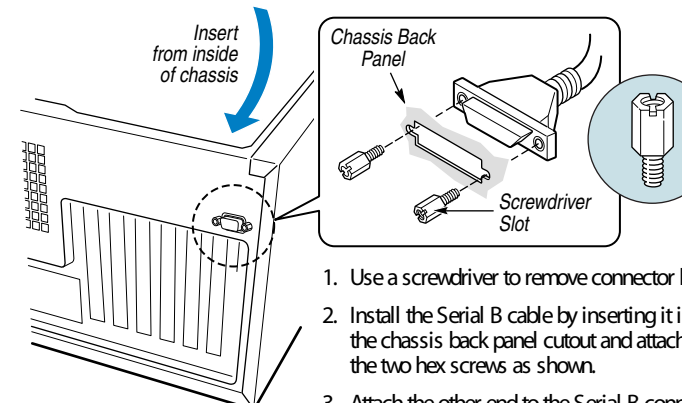

Serial B Back Location

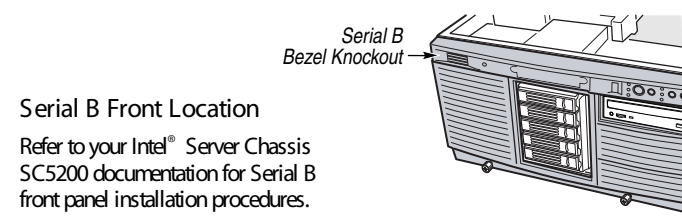

Serial B Front Location

Refer to your Intel® Server Chassis SC5200 documentation for Serial B front panel installation procedures.

10 Finishing Up

Before installing your operating system, you must finish your chassis installation, make I/O connections and plug in AC power.

- Replace the chassis cover.
- See your chassis documentation to complete rack or pedestal installation.
- Connect your keyboard, mouse, video, and other I/O cables as shown.
- Connect the AC power cable last.

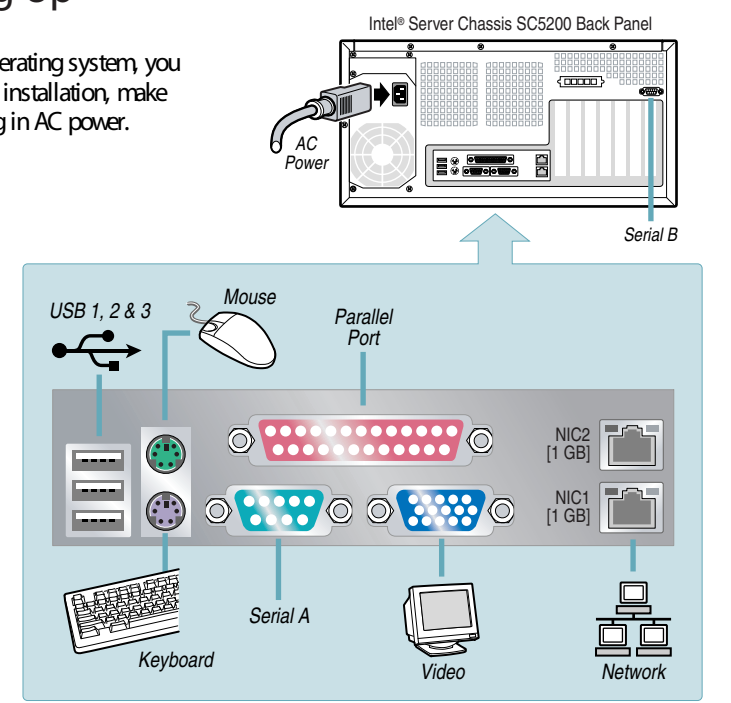

Reference

Server Board Component Layout

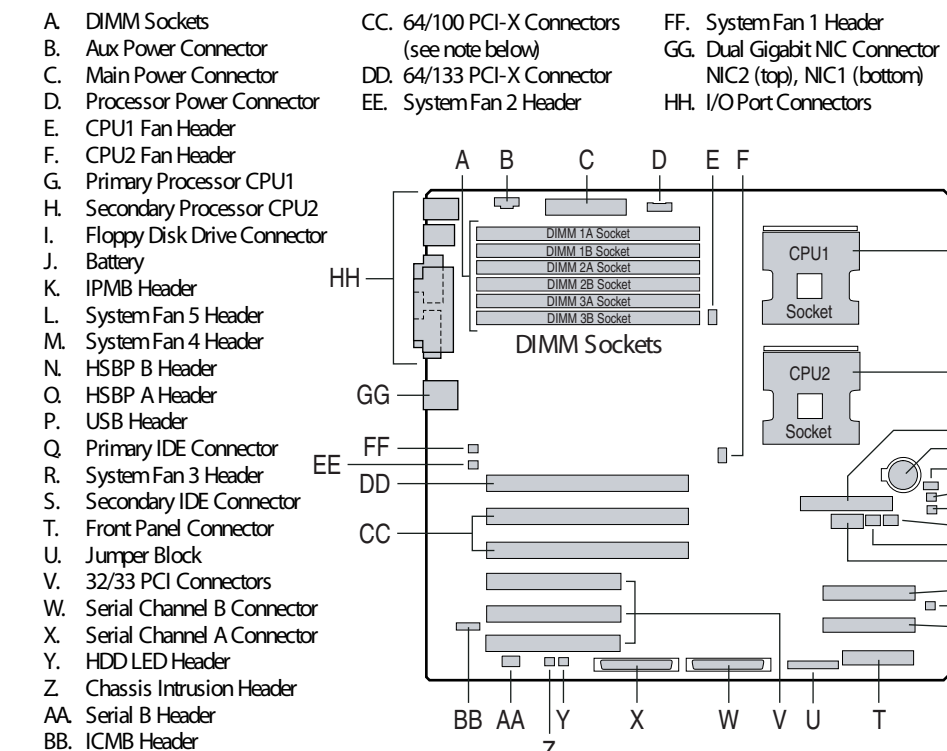

Note: PCI-X Slot 2 supports RAIDiOS Zero Channel RAID (ZCR) cards, such as the Intel® RAID Controller SRCZCR.

Common Problems and Solutions

For a list of hardware components that have been tested with this system, see: <http://support.intel.com/support/motherboards/server/SE7501HG2>

- The system does not boot or show video at power-on.
 - Check that the +12V CPU power connector is plugged in. Without this cable, the processors will not have any power.
 - If configuring with only one processor, verify that the processor is in the Primary Processor socket (CPU1).
 - Beep code 4-3-2-1 in a system using a 533 MHz Intel® Xeon™ processor means you have unrecognized or bad memory. Beep code 4-3-3-1 in a system using a 400 MHz Intel® Xeon processor means you have unrecognized or bad memory.
 - Remove and replace DIMMs one bank at a time to isolate which one is causing problems.
 - Remember, all DIMMs must be:
 - Registered DDR266-compliant 2.5V SDRAM (DDR200 DIMMs can be used if a 400 MHz Intel® Xeon processor is installed).
 - The same speed.
 - From the same manufacturer.
 - Installed beginning with DIMM 1A.
 - Paired with identical DIMMs in a bank.
 - Your power supply must provide a minimum of 450W with 2A standby current, which complies with the SSI EPS 12V specification.

- The system sometimes works, but is exhibiting erratic behavior.
 - This is typically the result of using an under-rated power supply. Make sure you are using at least a 450-W power supply which meets the SSI EPS 12V specification. For more information, see: <http://www.ssiforum.org>

Software

Getting Started with Intel® Server Management and Intel® SMarT Tool (optional)

Intel® Server Management software and the Service Partition provide real-time monitoring and alerting for your Intel® Server Board SE7501HG2, as well as emergency remote management and remote server update. Intel® Server Management is implemented by installing the software within the client-server architecture.

The Intel® Server Maintenance and Reference Training (SMaRT) Tool is an interactive software utility that provides support information to assist with the maintenance and repair of Intel® -based server systems and accessories. The Intel® SMarT Tool features visual, step-by-step instructions for replacing parts, a complete Field Replacement Unit (FRU) database containing part numbers and images, product spares lists, and worldwide Intel Support information.

Intel® Server Management provides an interface to the Intel® SMarT Tool so error detection and alerting are combined with interactive maintenance and repair assistance. To activate Intel® Server Management's interface with the Intel® SMarT Tool, both software programs need to be installed.

For more information on Intel® Server Management and the Intel® SMarT Tool, please refer to each respective CD that was included with your Intel® Server Board SE7501HG2.

Accessories and Order Codes	
Intel® Server Chassis SC5200 Base Configuration	KHD3BASE450
Intel® Server Chassis SC5200 Base Redundant Power (BRP) Configuration	KHD3RP450
Intel® Server Chassis SC5200 Hot Swap Redundant Power (HSRP) and Cooling Configuration	KHD3HSRP650
Intel® Server Chassis SC5200 Redundant Power and Cooling Rack Optimized Configuration	KHD3HSRP650R
Intel® Server Chassis SR1350-E	SR1350-E
Intel® Server Chassis SC5200 Spares Kit	FHD3SPRS
Intel® RAID Controllers	SRCZCR SRCU42L SRCU32U SRCU42X

A complete list of accessories and spares can be found at: www.intel.com/go/serverbuilder