



SR2300 2U Server Chassis

Technical Product Specification

Intel Order Number A94546-004

Revision 1.2

June 2003

Enterprise Platforms and Services Marketing



Revision History

Date	Revision Number	Modifications
4/02	0.5	First Preliminary Release
6/02	0.8	Updated content and illustrations
7/02	1.0	Release document
1/03	1.1	Updated to include SR7501WV2. Made corrections to pages 6-PSU voltage range; 26-tape drive bay & 55-segment A & B.
6/03	1.2	Made corrections to osection 6 – Hot Swap SCSI Backplane – remove reference to dul-mode SE device support.

Disclaimers

Information in this document is provided in connection with Intel® products. No license, express or implied, by estoppel or otherwise, to any intellectual property rights is granted by this document. Except as provided in Intel's Terms and Conditions of Sale for such products, Intel assumes no liability whatsoever, and Intel disclaims any express or implied warranty, relating to sale and/or use of Intel products including liability or warranties relating to fitness for a particular purpose, merchantability, or infringement of any patent, copyright or other intellectual property right. Intel products are not intended for use in medical, life saving, or life sustaining applications. Intel may make changes to specifications and product descriptions at any time, without notice.

Designers must not rely on the absence or characteristics of any features or instructions marked "reserved" or "undefined." Intel reserves these for future definition and shall have no responsibility whatsoever for conflicts or incompatibilities arising from future changes to them.

This document contains information on products in the design phase of development. Do not finalize a design with this information. Revised information will be published when the product is available. Verify with your local sales office that you have the latest datasheet before finalizing a design.

The SR2300 2U Server Chassis may contain design defects or errors known as errata which may cause the product to deviate from published specifications. Current characterized errata are available on request.

This document and the software described in it is furnished under license and may only be used or copied in accordance with the terms of the license. The information in this manual is furnished for informational use only, is subject to change without notice, and should not be construed as a commitment by Intel Corporation. Intel Corporation assumes no responsibility or liability for any errors or inaccuracies that may appear in this document or any software that may be provided in association with this document.

Except as permitted by such license, no part of this document may be reproduced, stored in a retrieval system, or transmitted in any form or by any means without the express written consent of Intel Corporation.

Intel, Pentium, Itanium, and Xeon are trademarks or registered trademarks of Intel Corporation.

*Other brands and names may be claimed as the property of others.

Copyright © Intel Corporation 2002 - 2003.

Table of Contents

1. Overview	1
1.1 Chassis Views	1
1.2 Chassis Dimensions	2
1.3 System Components	2
1.4 Chassis Back I/O Ports and Features.....	3
1.5 Chassis Front Panel and Peripheral Bays	4
1.5.1 Front Panel Controls and Indicators.....	5
1.5.2 Peripheral Bays.....	6
1.6 Power Supply.....	6
1.7 System Cooling.....	7
1.8 Chassis Security	7
1.9 Rack and Cabinet Mounting Options	7
1.10 Front Bezel Features	8
2. Power Sub-system	9
2.1 RPS500 1+1 power supply cage with TPS 500W SSI power supply modules	9
2.1.1 Power Supply Edge Connector Slot.....	11
2.1.2 Hot Swapping Power Modules	11
2.1.3 Intelligent Cage Functions.....	11
2.1.4 FRU Data	11
2.1.5 Power Supply Module	11
2.1.6 Air Flow	16
2.2 EPS2U 480W Power Supply	16
2.2.1 Air Flow	16
2.2.2 FRU Data	17
2.3 Power Supply Harness	17
2.3.1 P1 Baseboard Connector.....	18
2.3.2 P2 Power Management Signal Cable	18
2.3.3 P3 Power Management Signal Cable	18
2.3.4 P7 Hard Drive Interface Board Connector	19
2.4 Thermal Protection	19
3. Chassis Cooling	20
3.1 Fan Assembly	20

4. Chassis Peripheral Bays	24
4.1 Flex Bay.....	25
4.2 Hard Disk Drive Bays.....	25
4.2.1 Hard Disk Drive Trays	25
4.3 Tape Drive Bay	26
5. Front Panel Assembly.....	28
5.1 Front Panel Buttons and Intrusion Switch.....	28
5.2 Front Panel Assembly Connectors	29
5.3 Front Panel System Status LED Indicators	32
5.3.1 Power / Sleep LED	33
5.3.2 System Status LED	34
5.3.3 Drive Activity LED	35
5.3.4 System Identification LED	35
6. Hot-Swap SCSI Backplane	36
6.1 Hot-Swap SCSI Backplane Board Layout	36
6.2 SCSI Backplane Functional Architecture.....	37
6.2.1 Resets	37
6.2.2 Phillips* P80C652FBB Microcontroller.....	37
6.2.3 Symbios* SYM53C80S SCSI Controller	39
6.2.4 SCSI Interface.....	39
6.2.5 LVD to SE Bridge	39
6.2.6 SCSI Termination.....	39
6.2.7 Power Control	40
6.3 Power Connector	40
6.3.1 Power Requirements.....	41
6.3.2 Drive Activity / Fault LEDs.....	41
6.3.3 Internal Management Bus (IMB)	41
6.3.4 Local I ² C EEPROM and Temperature Sensor	41
6.4 SCA2 Hot-Swap Connectors	42
6.5 Baseboard to SCSI Interconnect	42
6.6 Server Baseboards SE7500WV2 and SE7501WV2 to CD/FDD/FP/Video Interface.....	43
6.7 Floppy/CDROM Module Connector	44
6.8 Front Panel Interface Connector.....	45
7. Floppy/CDROM and Floppy/DVD Module Interface Assemblies	47
7.1 CD-ROM Signal Interface	47

7.1.1	FDD Signal Interface	48
7.1.2	CD/FDD Signal Interface.....	48
7.2	CD-ROM/DVD Adapter Board	49
7.2.1	CD-ROM/DVD Signal Interface.....	50
7.2.2	FDD Signal Interface.....	51
8.	PCI Riser Cards	52
9.	Supported Intel® Server Boards.....	55
10.	Serial Port Usage.....	56
11.	Regulatory and Integration Information	57
11.1	Product Regulatory Compliance.....	57
11.1.1	Product Safety Compliance.....	57
11.1.2	Product EMC Compliance	57
11.1.3	Product Regulatory Compliance Markings	57
11.2	Electromagnetic Compatibility Notices	58
11.2.1	USA.....	58
11.2.2	FCC Verification Statement.....	58
11.2.3	ICES-003 (Canada).....	59
11.2.4	Europe (CE Declaration of Conformity).....	59
11.2.5	Japan EMC Compatibility	59
11.2.6	BSMI (Taiwan).....	59
11.3	Replacing the Back up Battery	59
12.	Environmental Limits.....	61
12.1	System Level Environmental Limits.....	61
12.2	System Environmental Testing.....	61
13.	Serviceability and Availability	62
14.	Calculated MTBF	63
	Appendix A: SR2300 Integration and Usage Tips.....	I
	Index.....	II

List of Figures

Figure 1. Chassis Front View with Bezel	1
Figure 2. Chassis Front View without Bezel	1
Figure 3. Chassis Back View – (500W with Redundent spare shown)	1
Figure 4. System Components	2
Figure 5. Chassis Back	3
Figure 6. Chassis Front.....	4
Figure 7. Controls and Indicators.....	5
Figure 8. Peripheral Bays	6
Figure 9. Optional Front Bezel	8
Figure 10. Power Supply Cage Mechanical Drawing.....	10
Figure 11. Outline Drawing Power System Enclosure	12
Figure 12. Edge Connector Layout	14
Figure 13. Power Supply Harness Detail	17
Figure 14. Fan Assembly Location	20
Figure 15. System Fan Connectors on Server Boards SE7500WV2 and SE7501WV2	21
Figure 16. Fan Module Assembly	23
Figure 17. Floppy/CDROM or Floppy/DVD Module	25
Figure 18. Hard Drive Tray Assembly	26
Figure 19. Mounting a Tape Drive	27
Figure 20. Front Panel Location.....	28
Figure 21. Front Panel Assembly.....	28
Figure 22. Front Panel Assembly Interface Board, Front View	29
Figure 23. Component Side Hot-Swap SCSI Backplane Connector Placement.....	36
Figure 24. SCSI Backplane Block Diagram	37
Figure 25. 80-pin SCA2 Connector.....	42
Figure 26. 68-pin SCSI Cable Connector	42
Figure 27. Floppy/CDROM Daughter Board	48
Figure 28. 2U PCI Riser Card Mechanical Drawing.....	54

List of Tables

Table 1. Chassis Dimensions	2
Table 2. Module Output Summary	11
Table 3. LED Indicators	13
Table 4. Edge Connector Pin-out.....	15
Table 5. 24-pin Baseboard Power Connector Pin-out	18
Table 6. Power Management Signal Cable Pin-out.....	19
Table 7. Hard Drive Interface Board Pin-out.....	19
Table 8. Individual Fan Pin-Out	21
Table 9. Fan Module Power/Signal Ribbon Cable	22
Table 10. Control Button and Intrusion Switch Functions	29
Table 11. External USB Connectors (J3).....	30
<i>Table 12. Video Connector</i>	<i>30</i>
Table 13. Internal USB Header (J2).....	31
Table 14. Front Panel (J1) to HDD Backplane Connector	31
• Table 15. Front Panel LED Functions	33
Table 16. SSI Power LED Operation	33
Table 17. SCSI Backplane Power Connector Pin-out.....	40
Table 18. Power Requirements	41
Table 19. Ultra2 (LVD) SCSI Connector Pin-out.....	42
Table 20. Floppy / FP / IDE Connector Pin-out.....	43
Table 21. 80-pin peripheral connector pin-out	44
Table 22. SCSI Backplane FP Connector Pin-out	46
Table 23. CD-ROM (ATA33) Interface Connector (J2) Pin-out.....	47
Table 24. FDD Interface Connector (J1) Pin-out	48
Table 25. SCA2 CD/FDD Interface Connector (J3) Pin-out.....	48
Table 26. CD-ROM (ATA33) Interface Connector (J1) Pin-out (CD/FDD Board Side).....	50
Table 27. CD-ROM (ATA33) Interface Connector (J2) Pin-out (CD-ROM Side)	51
Table 28. Max conditions for PCI Riser Cards	52
Table 29. 3V 64-bit PCI Connector Pin-out.....	53
Table 30. System Office Environment Summary	61
Table 31. Mean Time To Repair Estimate	62
Table 32. SR2300/SE7500WV2 Component MTBF	63
Table 33. SR2300/SE7501WV2 Component MTBF	63

< This page intentionally left blank. >

1. Overview

The SR2300 is a 2U server chassis that is designed to support the Intel® Server Boards SE7500WV2 and SE7501WV2. Both the boards and the chassis have a feature set that is designed to support the high-density server market. This chapter provides a high-level overview of the chassis features. Greater detail is provided in the following chapters.

1.1 Chassis Views

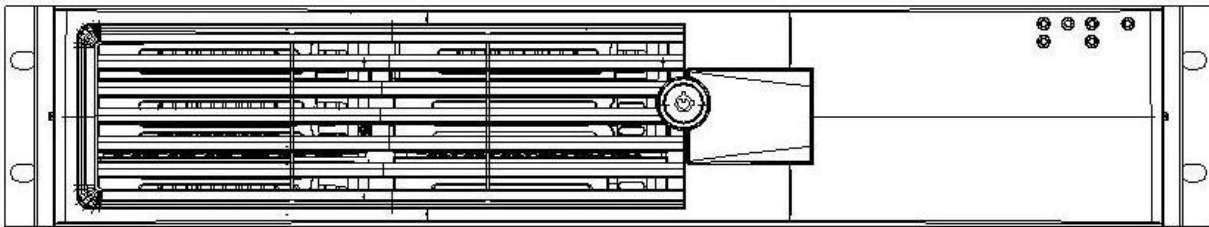

Figure 1. Chassis Front View with Bezel

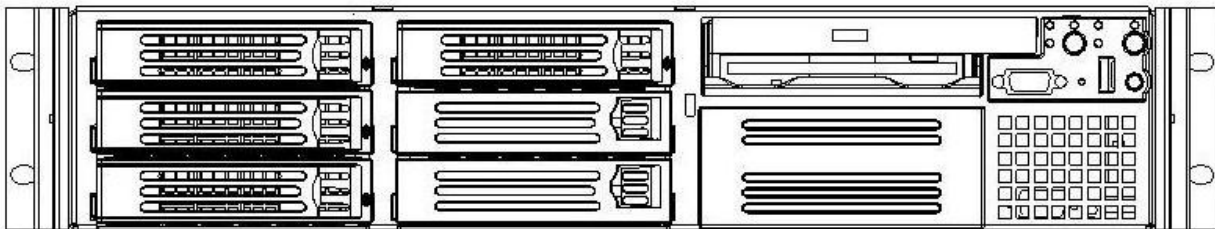

Figure 2. Chassis Front View without Bezel

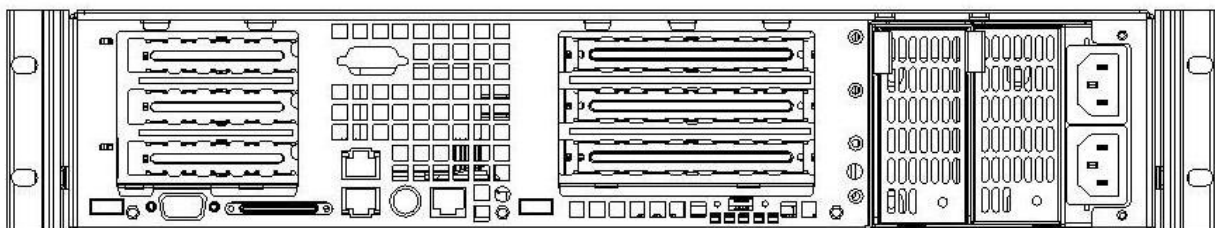

Figure 3. Chassis Back View – (500W with Redundant spare shown)

1.2 Chassis Dimensions

Table 1. Chassis Dimensions

Height	89 mm	3.504"
Width	430 mm	16.93"
Depth	648 mm	25.51"

1.3 System Components

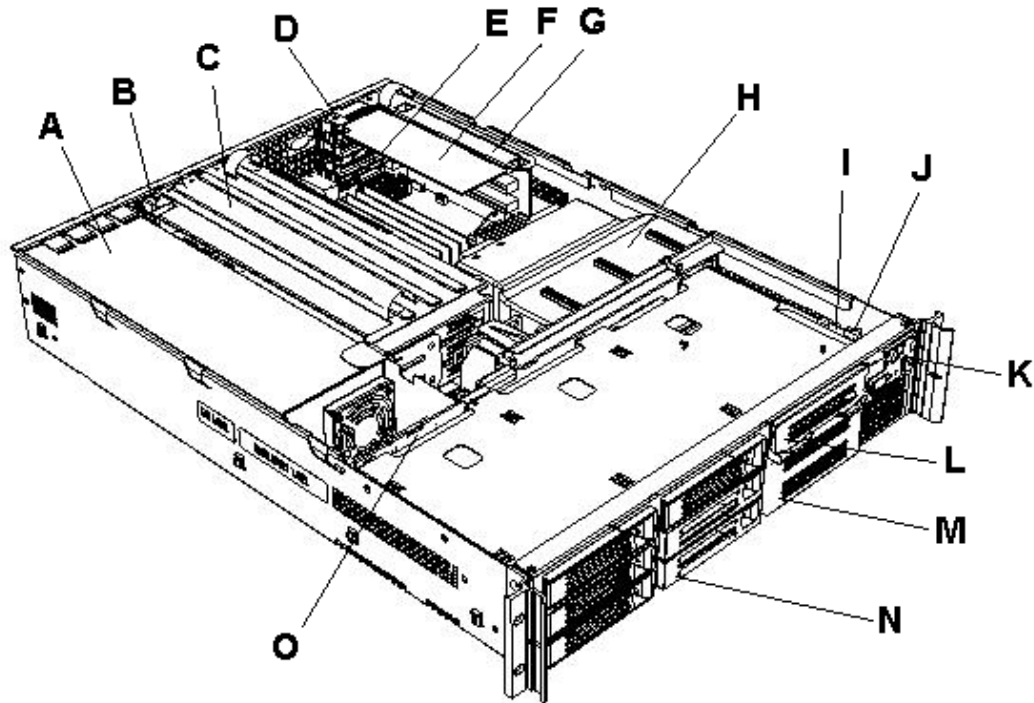

- A. Power supply
- B. PCI card bracket (full-length)
- C. Riser card assembly (full-length)
- D. PCI card bracket (low-profile)
- E. Server board (accessory to system)
- F. PCI add-in card (accessory to system)
- G. Riser card assembly (low-profile)
- H. System fans
- I. Front panel board
- J. Intrusion switch
- K. Control panel
- L. Flex bay (optional CD-ROM drive/FDD module available)
- M. Tape drive bay (tape drive available from others)
- N. Hard drive bay (one of six, accessory to system)
- O. Backplane board

Figure 4. System Components

1.4 Chassis Back I/O Ports and Features

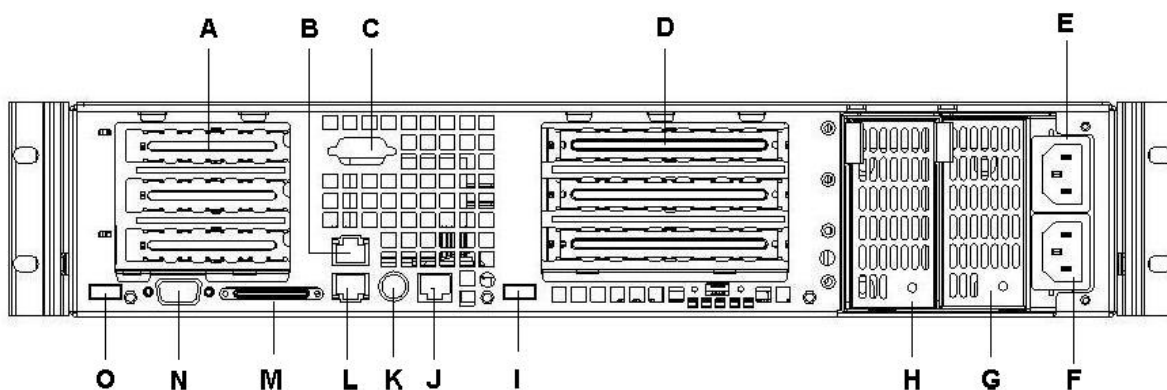

- | | |
|--|-------------------------------------|
| A. PCI card bracket (low profile) | I. USB connector 2 |
| B. RJ45 NIC 2 connector
Green Status LED / Yellow Status LED | J. RJ45 Serial B port |
| C. Serial A port mounting hole (cable
provided and installed by others) | K. PS/2 mouse/keyboard
connector |
| D. PCI card bracket (full-height) | L. RJ45 NIC 1 connector |
| E. AC power input (primary) | M. SCSI connector (If available) |
| F. AC power input (redundant – 500W
only) | N. Video connector |
| G. Power supply module, redundant
(system accessory) | O. USB connector 1 |
| H. Power supply module, primary | |

Figure 5. Chassis Back

The I/O connector locations on the back of the chassis are pre-cut, so the use of an ATX style I/O shield is not required. The supplied EMI gasket must be installed to maintain Electromagnetic Interference (EMI) compliance levels.

Note: The figure above is shown with a 500W power supply and the optional redundant 500W power supply spare.

1.5 Chassis Front Panel and Peripheral Bays

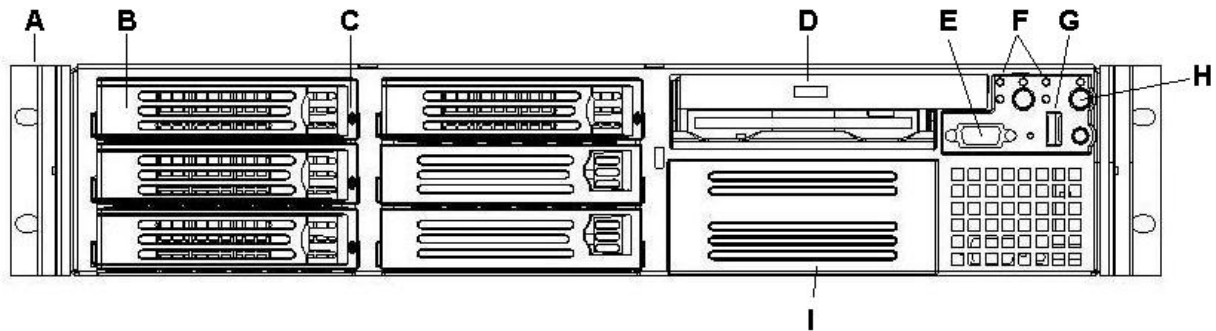

- | | |
|---|---------------------------------|
| A. Chassis handles (2) | F. Front panel indicator lights |
| B. Drive bay (1-inch) | G. USB connector 3 |
| C. HDD activity/fault indicator | H. System ID button |
| D. Flex bay (seventh HDD or optional CD-ROM drive/FDD module) | I. Tape drive bay filler panel |
| E. Front Video port connector | |

Figure 6. Chassis Front

1.5.1 Front Panel Controls and Indicators

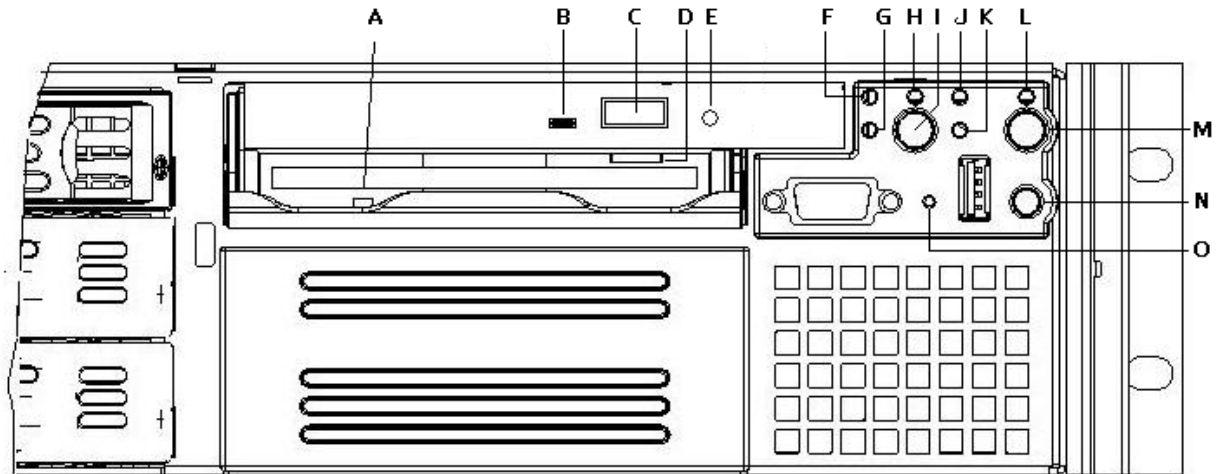

- | | |
|---|-------------------------------|
| A. FDD activity LED | I. Power button |
| B. CD-ROM activity LED | J. System status LED |
| C. CD-ROM drive eject button | K. Hard disk drive status LED |
| D. FDD eject button | L. ID LED |
| E. Manual CD-ROM drive eject button (Tool assisted) | M. ID button |
| F. NIC 1 activity LED | N. Reset button |
| G. NIC 2 activity LED | O. NMI button (tool assisted) |
| H. Power/sleep LED | |

Figure 7. Controls and Indicators

Note: The figure above is shown with an optional Floppy/CD-ROM or Floppy/DVD installed.

1.5.2 Peripheral Bays

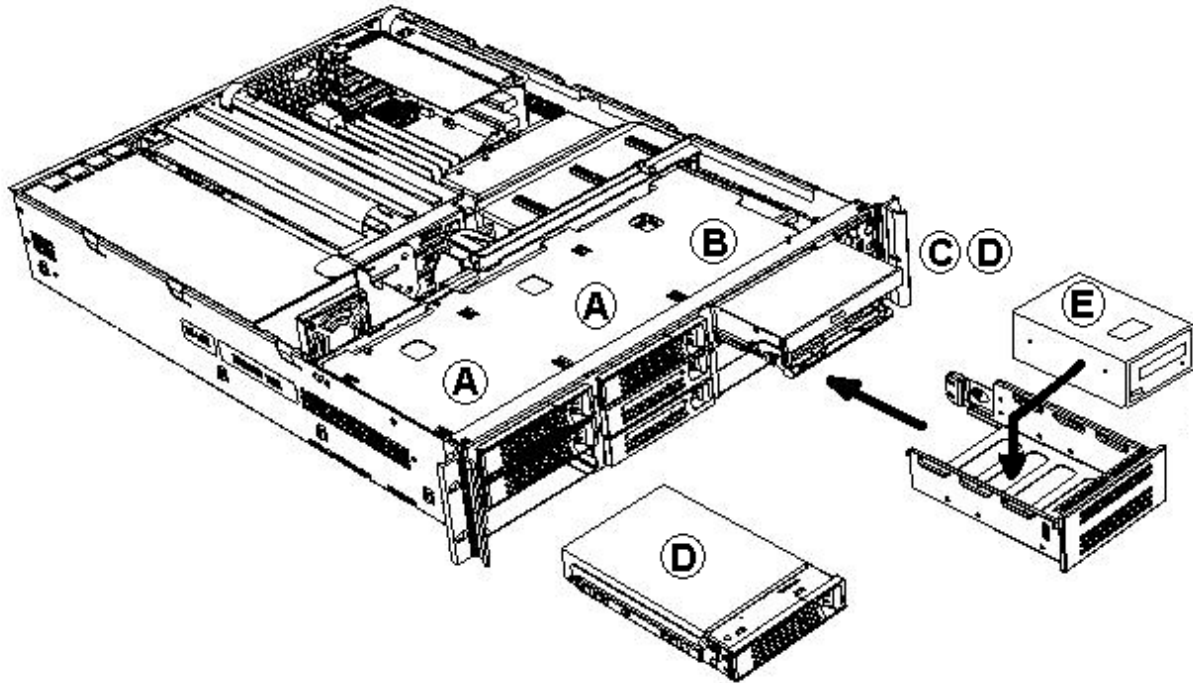

- A. Hard drive bays (6)
- B. Flex bay (1)
- C. CD-ROM drive / floppy disk drive module
- D. Hard disk drive
- E. Tape drive (available as a optional spare)

Figure 8. Peripheral Bays

1.6 Power Supply

The SR2300 supports two power supply models: An EPS2U 480W non-redundant power supply and the TPS 500W supply supporting redundant 1+1 configurations with TPS500W modules. The power subsystem supports the implementation of remote management features, including remote enable that permits power to be activated from a variety of sources.

The TPS 500W supply consists of the power supply bay and one power supply module. A second power supply module can be purchased to provide a redundant, 1+1 system. The supply operates within the following voltage ranges and is rated as follows:

- 90 - 132VAC~ at 50/60 Hertz (Hz); 7.0A maximum
- 180 - 264VAC~ at 50/60 Hz; 3.5A maximum

The EPS1U 480W supply consists of a single integrated power supply unit. It operates within the following voltage ranges and is rated as follows:

- 90 - 132VAC ~ at 50/60 Hertz (Hz); 8.4A maximum
- 180 - 264VAC ~ at 50/60 Hz; 4.2A maximum

With either power supply configuration, the power supply provides 480 watts of power and is designed to minimize EMI.

1.7 System Cooling

The chassis includes three 60-mm non-hot-swappable system fans for cooling the processor(s), hard drives, and add-in cards. A fourth fan may be added in the fan2 position to provide conditional cooling redundancy for system components. The system fans are mounted in a fan assembly located in the middle of the chassis to pull cooling air through the chassis. The power supplies contain a single fan for cooling.

1.8 Chassis Security

To help prevent unauthorized access to the system's peripherals and control panel, an optional key-locked front bezel can be used. The chassis also includes a preinstalled intrusion switch that can be monitored by server management software. When the cover is opened, a switch located on the front panel board transmits a signal to the Baseboard Management Controller (BMC) on the server board. Through server management software, the system can be programmed to respond to an intrusion by powering down or by locking the keyboard. At the chassis level a variety of security options are provided.

1.9 Rack and Cabinet Mounting Options

The SR2300 chassis was designed to support 19" wide by up to 30" deep server cabinets. The chassis comes equipped with a relay rack or cabinet mount kit that can be configured to support front-mount or mid-mount 2-post racks and 4-post cabinets. Intel also provides an optional sliding rail kit that is used to mount the chassis into a standard (19" by up to 30" deep) EIA-310D compatible server cabinet.

For mounting in a regular server cabinet, the front mount brackets are attached to the front of the chassis, and a set of rear support brackets are attached to the back end of the cabinet. This evenly distributes the server to prevent the mounting rails on the cabinet from bending. Caution should be used in using the front mount-only option. Even though the rail mount kit hardware was designed to support the weight of the system, some 2-post relay racks may not, causing the racks to fail. Only use relay racks that are specifically designed to support the weight and stresses of a 2-post front-mount only chassis.

1.10 Front Bezel Features

The optional front bezel is made of molded plastic and uses a snap-on design. When installed, this design provides for maximum airflow. By using light pipes, system status LEDs can be monitored with the front bezel in the closed position.

The front bezel lock provides security for the hard drives, peripheral devices and front panel control.

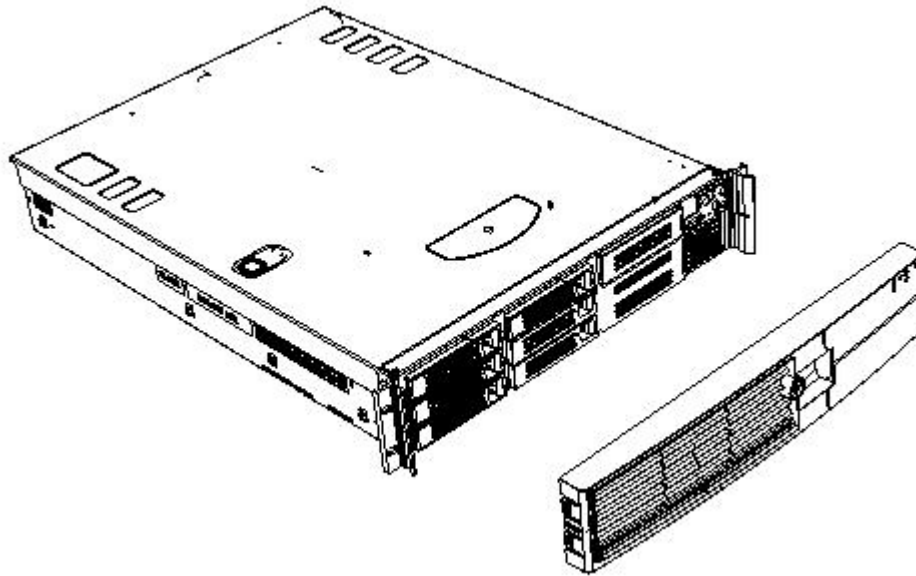

Figure 9. Optional Front Bezel

2. Power Sub-system

This section provides an overview of the SR2300 power supply sub-system. For additional details, refer to the *SR2300 Power Supply Specification*. Two power supplies models are supported in the SR2300. The first is a RPS500 1+1 redundant power supply supporting 1 or 2 TPS 500W modules. The second is the EPS2U 480W non-redundant power supply.

2.1 RPS500 1+1 power supply cage with TPS 500W SSI power supply modules

The RPS500 power supply cage can support up to two TPW 500W SSI power supply modules in a 1+1 configuration or a non-redundant single module configuration (1+0). The cage incorporates dual AC inputs with two EMI filters.

A mechanical drawing for the power supply cage is provided on the following page.

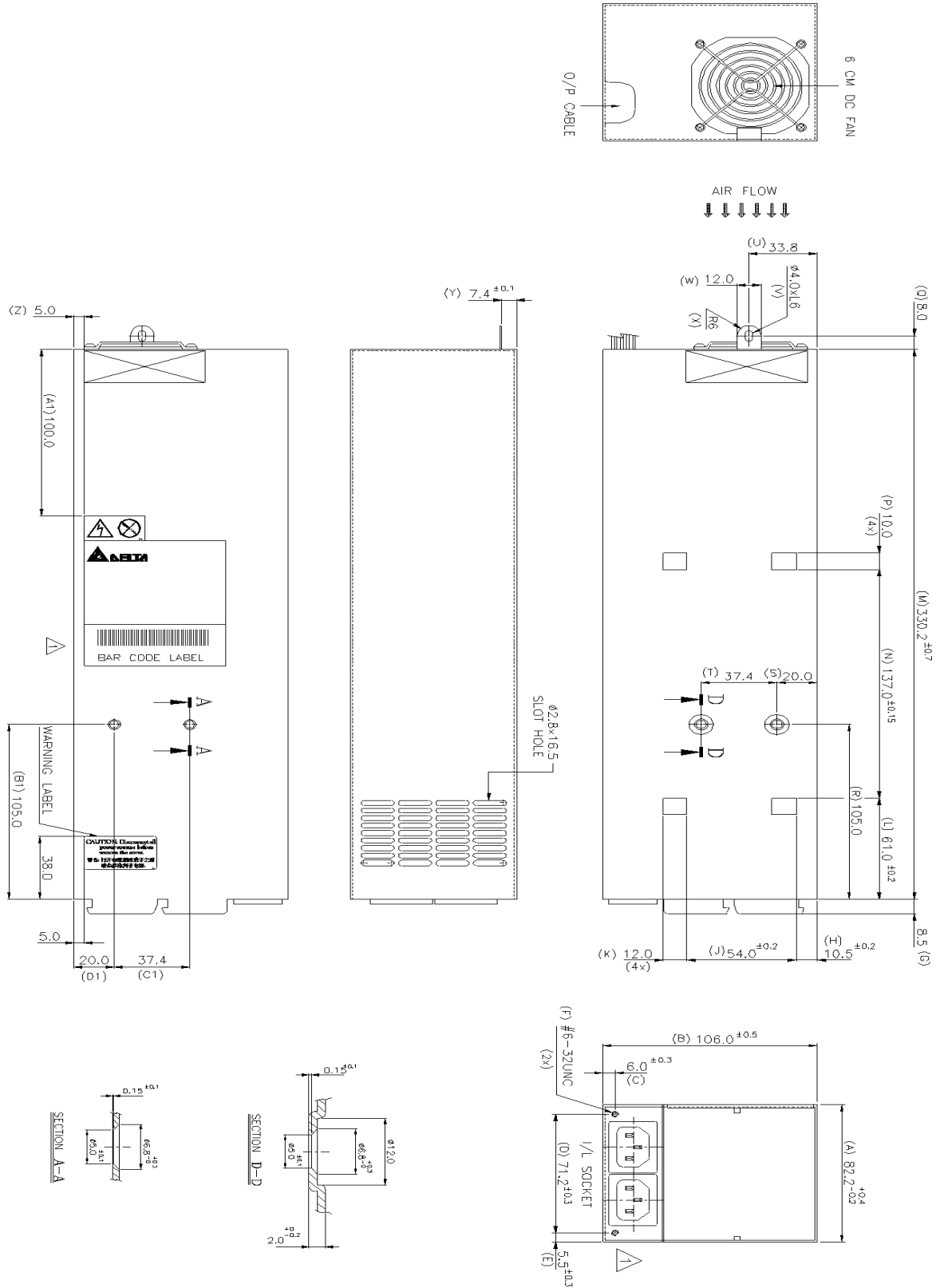

Figure 10. Power Supply Cage Mechanical Drawing

2.1.1 Power Supply Edge Connector Slot

See Section 2.1.5 for details.

2.1.2 Hot Swapping Power Modules

The SR2300 power supply cage is capable of supporting hot swapping of power supply modules in a 1+1 configuration. Hot swapping a power supply module is the process of extracting and inserting a power supply module from an operating system.

2.1.3 Intelligent Cage Functions

The power supply cage contains a Microchip* PIC16C74B OTP or PIC16C74C:MASK ROM microcontroller to monitor the status of the modules and provide control functions for the cage. The microcontroller is configured as a slave device on the SMBus. The statuses of the module and cage signals are available via the SMBus interface. The SMBus is also connected to each power module. The microcontroller is powered by 5Vstandby and is connected to the ground on the power share board. The microcontroller makes use of the watchdog timer to reset the device in case the controller locks up.

2.1.4 FRU Data

The power supply cage contains a 2 KB EEPROM device that contains FRU data for the cage according to the IPMI spec. Each separate output is given a different number for identification purposes.

2.1.5 Power Supply Module

The SR2300 power system supports one 500W SSI TPS (Thin Power Supply) module for a non-redundant configuration, or two in a 1+1 redundant configuration. The power supply module provides three outputs; 5V, 12V, -and 12.

The power supply module contains no fans. However, a fan in the power supply cage provides cooling to the module. The module provides a handle to assist in insertion and extraction and can be inserted and extracted without the assistance of tools.

Table 2. Module Output Summary

	+12V	-12V	5VSB
MAX	40A	0.5A	2.5A
MIN STATIC	0A	0A	0A
MIN DYNAMIC	1.5A	0A	0A

2.1.5.1 Power Supply Module Mechanical

The power supply module mechanical outline and dimensions are shown in the figure below.

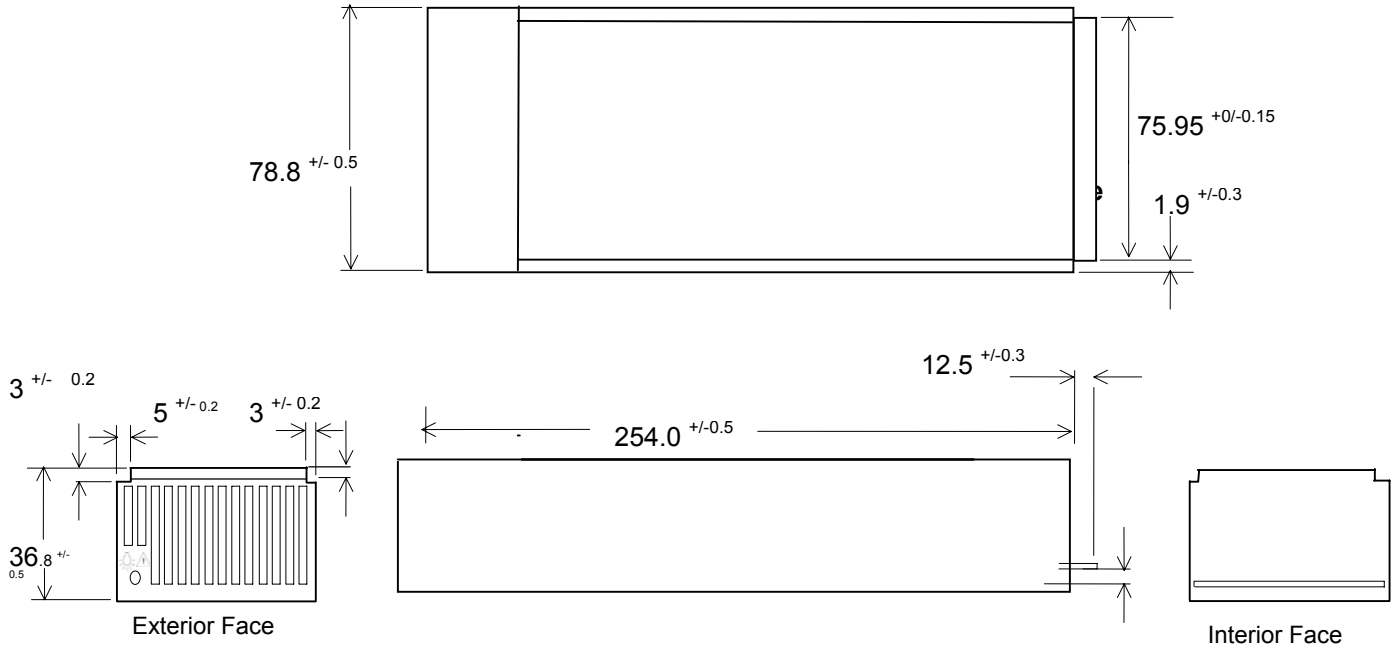

2.1.5.2 Power Supply LED Indicator

The power supply module provides a single external bi-color LED to indicate the status of the power supply. When AC is applied to the PSU and standby voltages are available, the LED will blink green. The LED will be solid on green to indicate that all the power outputs are available. The LED will be solid on amber to indicate that the power supply has failed, shutdown due to over current, shutdown due to over temperature, or is indicating a predictive failure. Refer to the following table for conditions of the LED.

Table 3. LED Indicators

POWER SUPPLY CONDITION	Power Supply LED
No AC power to all PSU	OFF
No AC power to this PSU only	AMBER
AC present / Only Standby Outputs On	BLINK GREEN
Power supply DC outputs ON and OK	GREEN
Power supply failure (includes over voltage, over temperature)	AMBER
VRM failure (cage related)	BLINK GREEN
240VA limit (cage related)	BLINK GREEN
Current limit	AMBER

2.1.5.3 Power Supply Module to Cage Interconnect

The power supply module provides edge fingers that mate to a connector located in the power supply cage. This is a blind mating type connector that connects the power supply's input voltage, output voltages and signals. The following diagram shows edge connector pin layout.

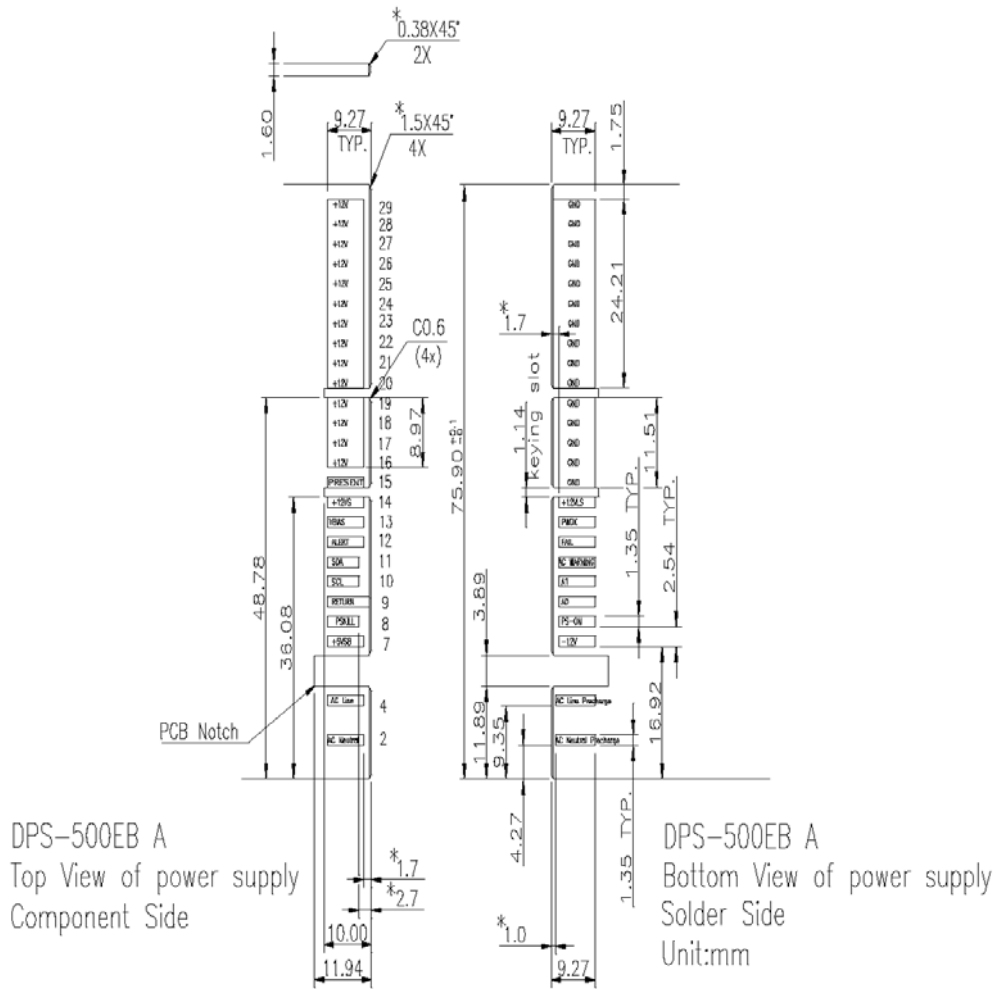

Figure 12. Edge Connector Layout

The following table provides the pin-out for the power supply edge connector.

- Signals that can be defined as low true or high true use the convention: *signal#*= low true
- Reserved pins are for future use.
- No Connect (NC) locations must be empty locations on the power supply edge card and in the mating connector to meet spacing requirements.

Table 4. Edge Connector Pin-out

Description	Pin#	Pin#	Description
NC	B1	A1	NC
AC Neutral Pre-charge	B2	A2	AC Neutral
NC	B3	A3	NC
AC Line Pre-charge	B4	A4	AC Line
NC	B5	A5	NC
NC	B6	A6	NC
-12V	B7	A7	5VSB
PS-ON	B8	A8	PSKill
A0	B9	A9	Returns
A1	B10	A10	SCL
AC warning	B11	A11	SDA
Fail	B12	A12	Alert#
PWOK	B13	A13	Vbias
12LS	B14	A14	+12VS
Ground	B15	A15	Present#
Ground	B16	A16	+12V
Ground	B17	A17	+12V
Ground	B18	A18	+12V
Ground	B19	A19	+12V
Ground	B20	A20	+12V
Ground	B21	A21	+12V
Ground	B22	A22	+12V
Ground	B23	A23	+12V
Ground	B24	A24	+12V
Ground	B25	A25	+12V
Ground	B26	A26	+12V
Ground	B27	A27	+12V
Ground	B28	A28	+12V
Ground	B29	A29	+12V

Keying Locations

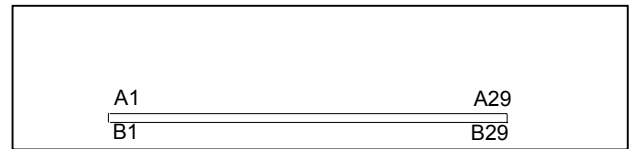

Interior Face

2.1.6 Air Flow

The TPS 500W 1+1 cage contains one 60 x 38mm fan for self-cooling. The cooling air enters the subsystem from the DC connector side, passing through the power supply. The air flowing through the power supply is pre-heated by the system. Inlet air to the power supply shall be in the range of 0 to 50°C. The cage provides 8 CFM at 50 C per module for a 480W total cage load.

2.2 EPS2U 480W Power Supply

The EPS2U 480W Power Supply is a single power supply unit with integrated cooling fan. Following is the mechanical drawing of the EPS2U 480W power supply:

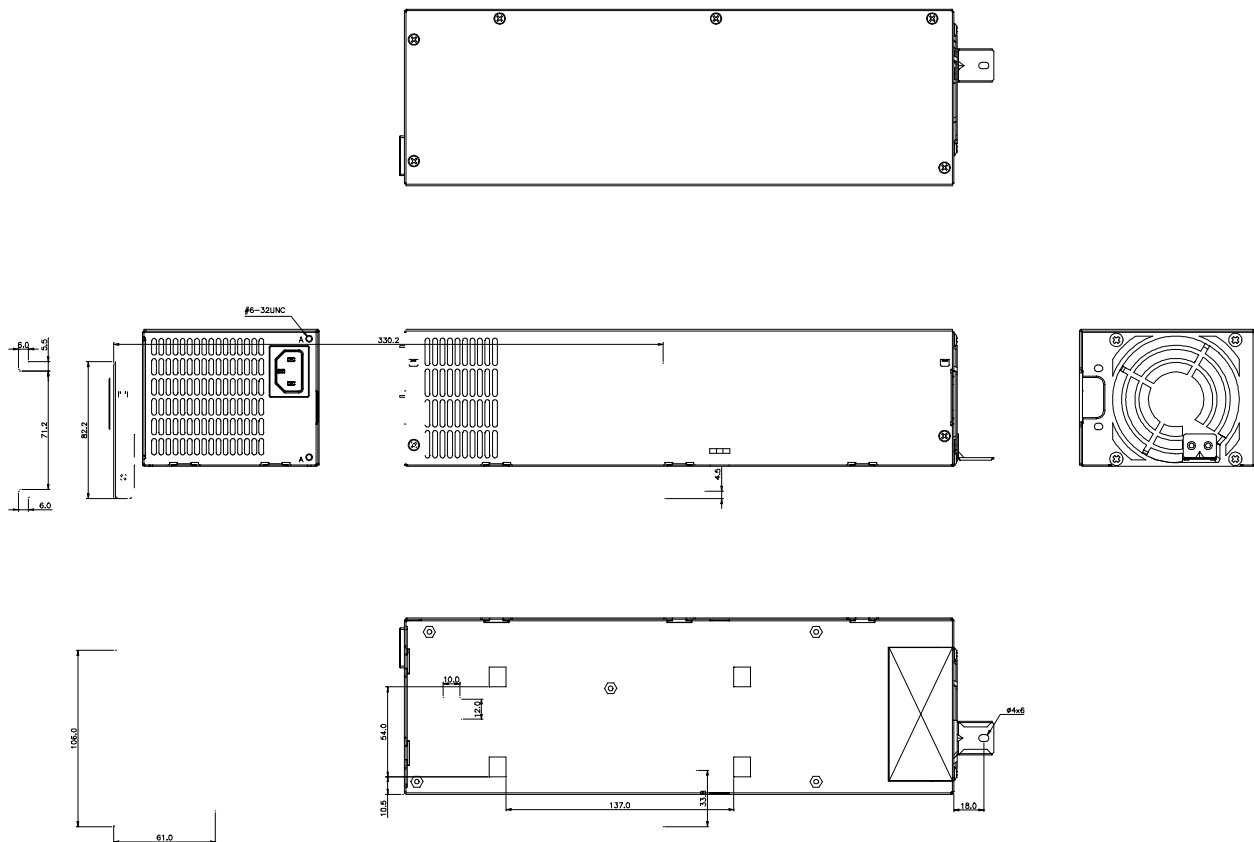

2.2.1 Air Flow

The EPS2U 480W has an 80X38mm two-speed fan(s) and provides cooling to both the supply and the system. The cooling air enters the subsystem from the DC connector side, passing through the power supply. The air flowing through the power supply is pre-heated by the system. Inlet air to the power supply shall be in the range of 0 to 50°C. At high fan speed, the power supply provides 19 CFM of airflow.

2.2.2 FRU Data

The power supply cage contains a 2 KB EEPROM device that contains FRU data for the power supply according to the IPMI specification. Each separate output is given a different number for identification purposes.

2.3 Power Supply Harness

The figure below shows the harness lengths and designators for both power supply options. The DC output harness connectors are UL1007 rated: 105°C, 300V or an Intel-approved equivalent. Each connector is described in detail in the following sections.

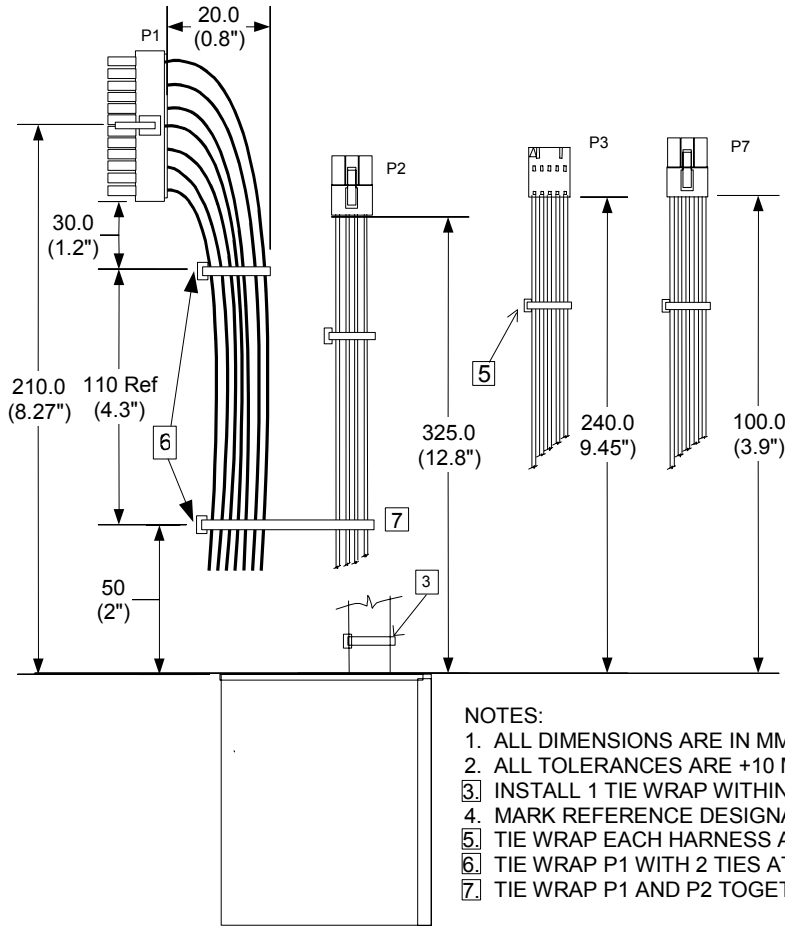

Figure 13. Power Supply Harness Detail

2.3.1 P1 Baseboard Connector

A 24-pin Molex* 39-01-2245 connector and harness from the power supply provides the server boards SE7500WV2 and SE7501WV2 with the required voltages and interface signals. The following table provides the connector pin-out.

Table 5. 24-pin Baseboard Power Connector Pin-out

Pin	Signal	18 AWG COLOR	Pin	Signal	18 AWG COLOR
1	+3.3 Vdc	Orange	13	+3.3Vdc	Orange
2	+3.3 Vdc	Orange	14	-12Vdc	Blue
3	COM	Black	15	COM	Black
4	+5 Vdc	Red	16	PS_ON#	Green
5	COM	Orange	17	COM	Black
6	+5 Vdc	Red	18	COM	Black
7	COM	Black	19	COM	Black
8	PWR OK	Gray	20	Reserved	NC
9	5 VSB	Purple	21	+5VDC	Red
10	+12 Vdc	Yellow	22	+5VDC	Red
11	+12 Vdc	Yellow	23	+5VDC	Red
12	+3.3 Vdc	Orange	24	COM	Black

2.3.2 P2 Power Management Signal Cable

An 8-pin Molex 39-01-2080 connector and harness from the power supply connects to the server boards SE7500WV2 and SE7501WV2 to provide power to the processor subsystem. The following table provides the connector pin-out.

Pin	Signal
1	Common
2	Common
3	Common
4	Common
5	+12V3
6	+12V3
7	+12V3
8	+12V3

2.3.3 P3 Power Management Signal Cable

A 5-wire cable with a Molex 50-57-9405 female housing connector is used to direct power management signals to the server boards SE7500WV2 and SE7501WV2. The following table shows the pin-out.

Table 6. Power Management Signal Cable Pin-out

Pin	Signal	Description
1	SMBus-SCL	Serial Clock
2	SMBus-SDA	Serial Data. Information from the power supply
3	Reserved	Reserved
4	COM	Return remote sense
5	3.3VS	3.3V sense

2.3.4 P7 Hard Drive Interface Board Connector

A 6-wire cable with a Molex Mini-Fit Jr. PN# 39-01-2065 connector is used to provide power to the SCSI backplane board for drive power.

Table 7. Hard Drive Interface Board Pin-out

Pin	Signal	22 AWG COLOR
1	Ground	Black
2	Ground	Black
3	5V	Red
4	12V	Yellow
5	12V	Yellow
6	3.3V	Orange

2.4 Thermal Protection

The power supplies incorporate thermal protection that will cause a shut down if airflow through the power supply is insufficient. Thermal protection shall activate shutdown if the temperature of any power supply component is more than 85% (°C) of rated temperature. This shutdown shall take place before over-temperature induces damage to the power supply.

3. Chassis Cooling

A three-fan module, the power supply fan and ducting provide the necessary airflow to cool the system.

3.1 Fan Assembly

The primary airflow for the system is provided by a removable plastic fan housing which secures up to four 60mm x 38mm multi-speed fans. The base system ships with three fans, and a blank panel to prevent air re-circulation. Adding a fourth fan provides conditional airflow redundancy. If one of the fans should fail, the remaining two will increase their rotation and attempt to maintain the thermal requirements of the system.

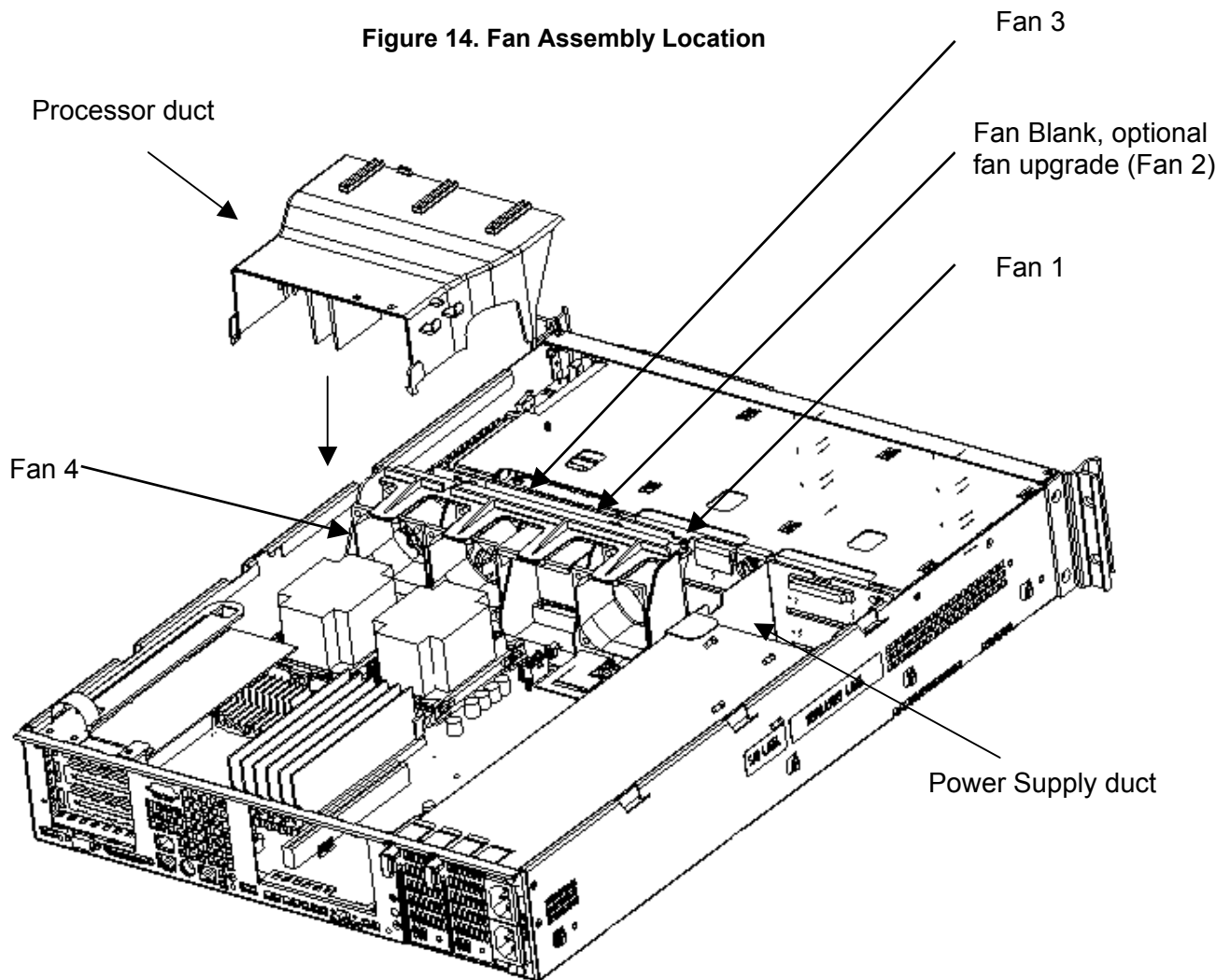

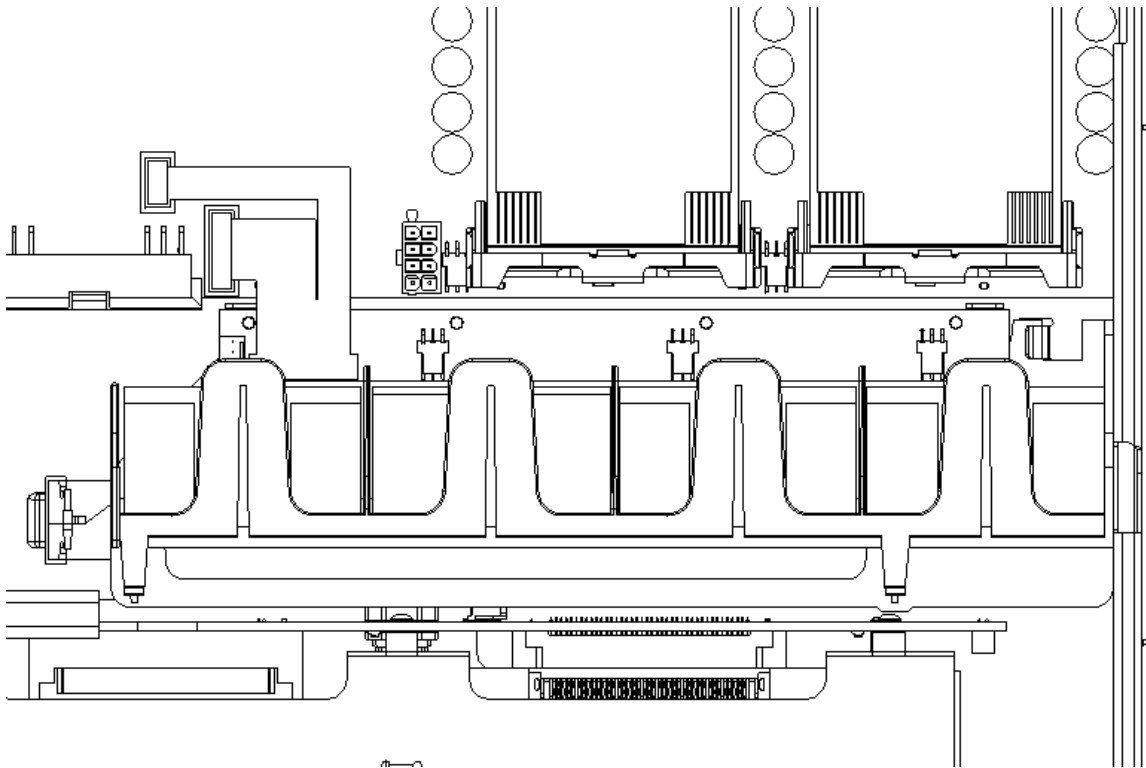

Figure 15. System Fan Connectors on Server Boards SE7500WV2 and SE7501WV2

A 3-wire cable/connector provides each fan with power and tachometer output, allowing it to be monitored independently by server management software. The following table provides the pin-out for the 3-wire cable/connectors on each fan and corresponding header on the fan board.

Table 8. Individual Fan Pin-Out

Pin	Signal Name	Description
1	Return	Ground return
2	12V power	VCC
3	Tachometer	Two pulse per revolution speed monitor

The following table provides the pin-out for the ribbon cable that connects the fan distribution board to the server boards SE7500WV2 and SE7501WV2.

Table 9. Fan Module Power/Signal Ribbon Cable

Ribbon Cable Connection		
(Fan Brd)	Via Conductor	To
P1-1	1 (RED Wire)	P3-6
P1-2	2	P3-5
P1-3	3	P3-4
P1-4	4	P3-3
P1-5	5	P3-2
P1-6	6	P3-1
P1-7	7	P2-12
P1-8	8	P2-11
P1-9	9	P2-10
P1-10	10	P2-9
P1-11	11	P2-8
P1-12	12	P2-7
P1-13	13	P2-6
P1-14	14	P2-5
P1-15	15	P2-4
P1-16	16	P2-3
P1-17	17	P2-2
P1-18	18	P2-1
P1-19	19	Remove Conductor
P1-20	20	Remove Conductor

Each fan within the module is capable of supporting multiple speeds. At normal room ambient of 23C, the fans will run at slow speed for best acoustic performance. If the external temperature of the system increases, the SE7500WV2 and SE7501WV2 baseboards will increase fan speed to compensate for the increased ambient. Fans are not hot swappable. The server must be turned off before a fan can be replaced.

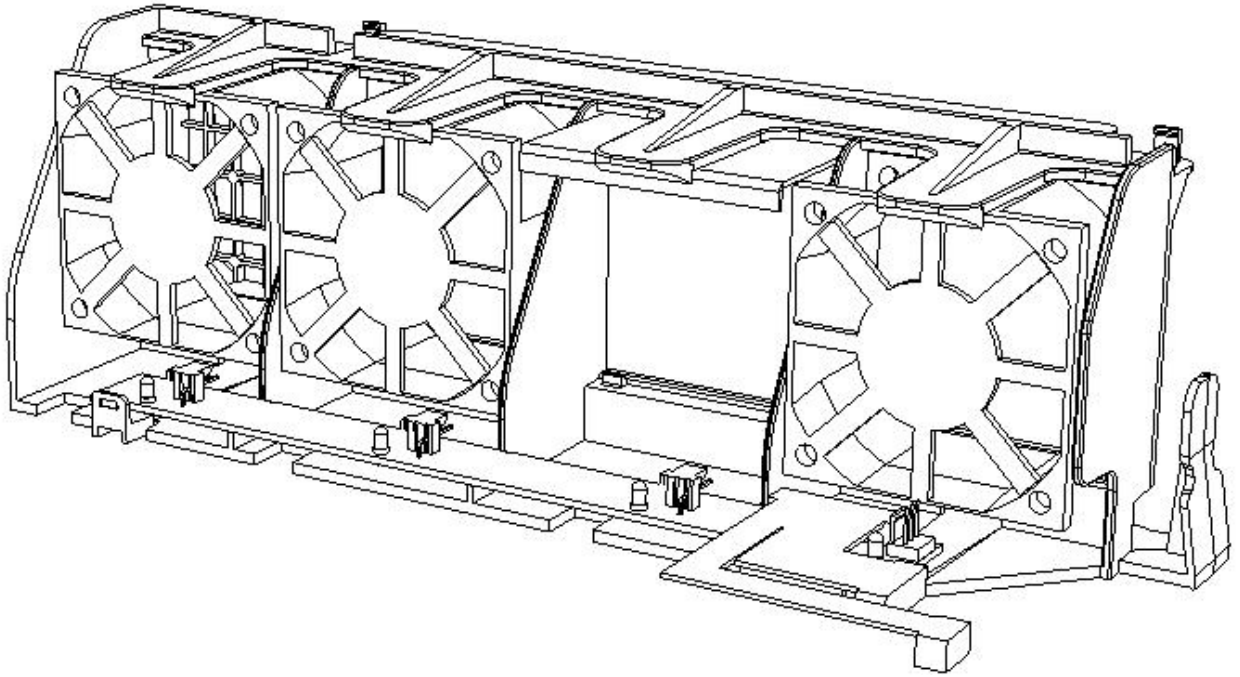
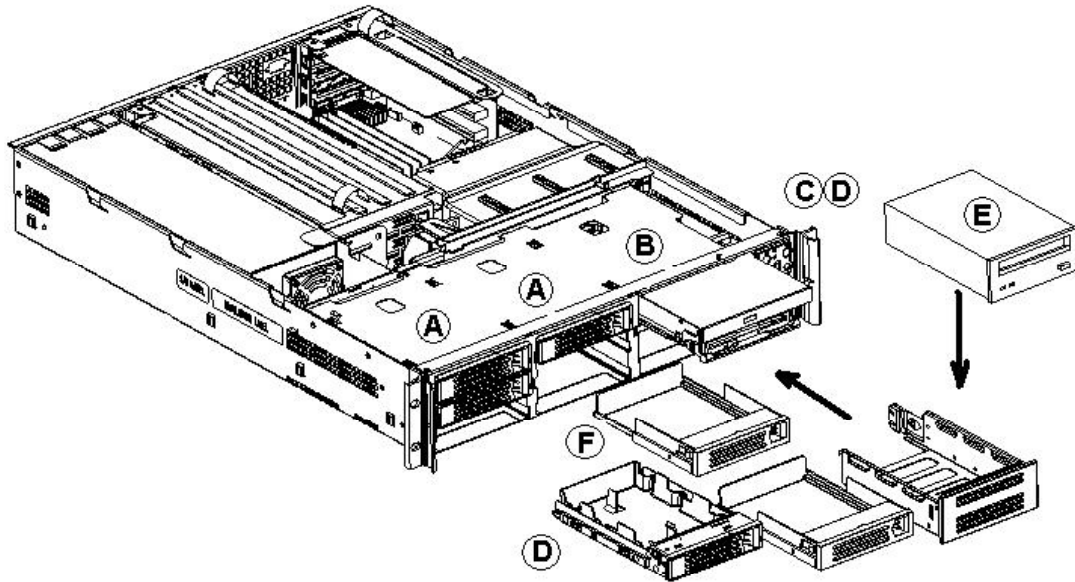

Figure 16. Fan Module Assembly

4. Chassis Peripheral Bays

The SR2300 server chassis provides six hard drive bays at the front of the chassis. An optional seventh drive may be used in the flex bay. All hard drive bays may be populated with a tray-mounted 3.5" hard disk drive. If a configuration requires the use of a floppy disk drive and CD-ROM or DVD drive, an optional Floppy/CDROM or Floppy/DVD module may be used in place of the seventh hard drive in the flex bay. A tape drive bay is located below the flex bay.



- A. Hard drive bays (6)
- B. Flex bay (1)
- C. CD-ROM drive/floppy disk drive module
- D. Hard disk drive
- E. Tape drive (available from others)
- F. Standard shipping config includes drive blanks slot 4 and 5 (as shown)

4.1 Flex Bay

For those configurations that require a floppy drive and CD-ROM or DVD drive, the seventh drive bay or “Flex Bay” can be configured as a peripheral bay by inserting an optional Floppy/CDROM or Floppy/DVD Module. The Floppy/CDROM or Floppy/DVD Module is a 3.5” floppy drive and a 0.5” (12.7mm) slim-line CD-ROM or DVD drive mounted as a single unit in the peripheral bay. A release latch allows for tool-less removal from the front of the server, however, these modules are not hot swappable. The system must be powered down before the module is inserted or removed from the flex bay.

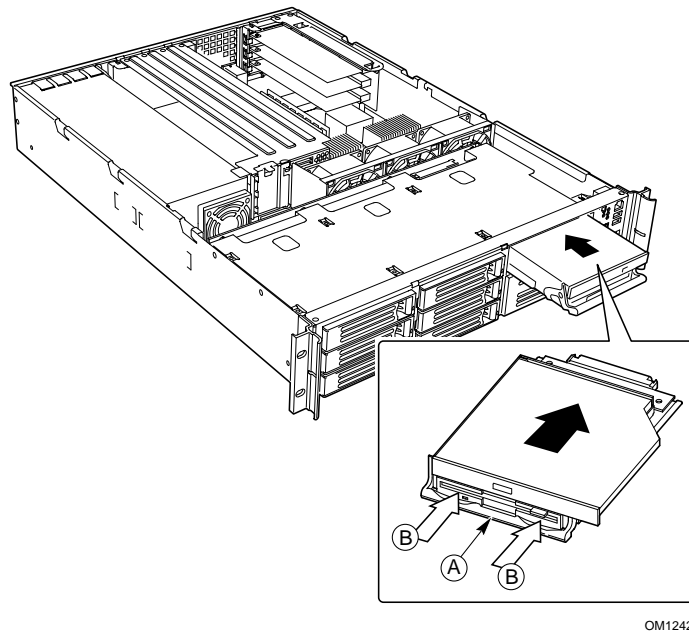

OM12420

Figure 17. Floppy/CDROM or Floppy/DVD Module

4.2 Hard Disk Drive Bays

The SR2300 server chassis can support up to seven tray-mounted SCA2, 3.5” x 1”, Ultra2/Ultra160/U320 hard disk drives. For RAID configurations, the SCSI drives may be hot-swapped while the system is running.

4.2.1 Hard Disk Drive Trays

Each hard drive used in the system must be mounted to a drive tray, making insertion and extraction of the drive from the chassis very simple. Each drive tray has its own dual purpose latching mechanism which is used to both insert/extract drives from the chassis and lock the tray in place. Each drive tray supports a light pipe providing a drive status indicator, located on the backplane, to be viewable from the front of the chassis.

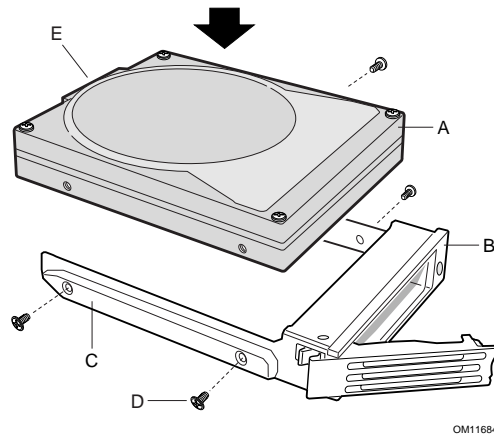

OM11884

Figure 18. Hard Drive Tray Assembly

- A. Hard Drive
- B. Drive Carrier
- C. Side Rail
- D. Mounting Screw
- E. Hard Drive Connector

4.3 Tape Drive Bay

The user can purchase a tape drive and install it in the 3.5-inch drive bay using the carrier provided. The optional tape drive accessory must be used. This accessory includes a power cable to power the tape drive to the SCSI backplane and a round SCSI cable to connect the tape drive to onboard SCSI PCI add in card. The server boards SE7500WV2 and SE7501WV2 onboard internal SCSI connector will be required to connect to the server chassis SR2300 SCSI backplane.

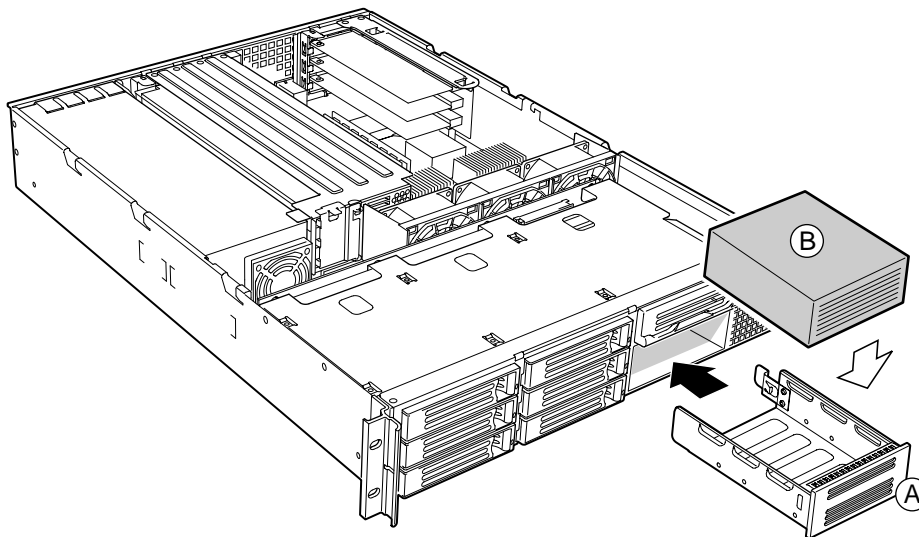

OM12409

- A. Tape Drive Tray

B. Tape Drive

Figure 19. Mounting a Tape Drive

Note: To remove the tape drive tray (A) from the chassis, a spring latch located inside the chassis on the back right side of the carrier must be released to allow the drive tray to slide free. Do not attempt to pull out the drive tray without first releasing the spring latch. Doing so may damage the plastic faceplate.

5. Front Panel Assembly

The SR2300 front panel assembly is located on the right side of chassis and consists of an interface board, front panel and three I/O connectors

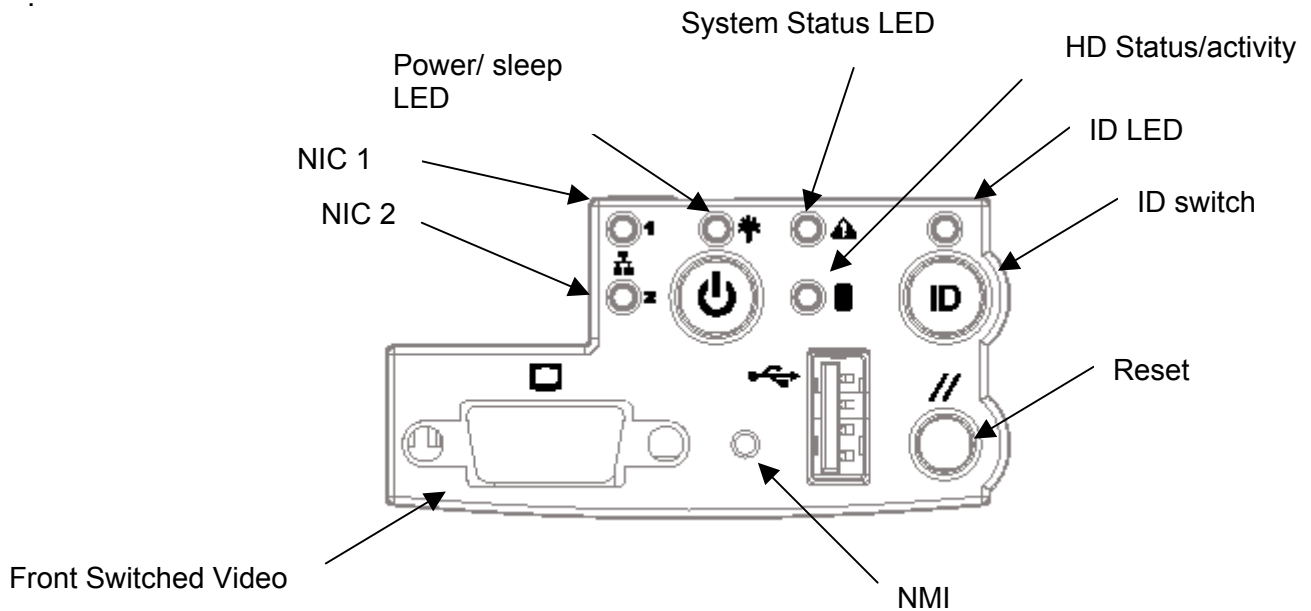

Figure 20. Front Panel Location

5.1 Front Panel Buttons and Intrusion Switch

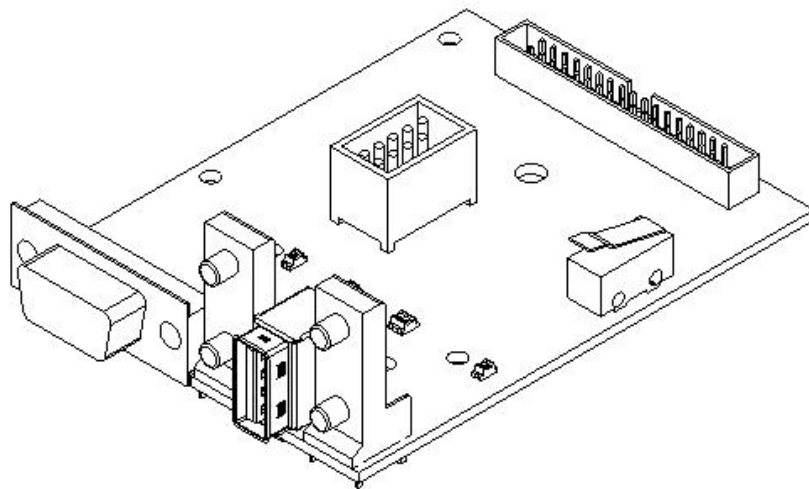

Figure 21. Front Panel Assembly

The SR2300 front panel assembly houses several system control buttons and a chassis intrusion switch. Each of their functions is listed in the table below.

Table 10. Control Button and Intrusion Switch Functions

Feature	Function
Power button	Toggles the system power on/off. This button also functions as a Sleep Button if enabled by an ACPI-compliant operating system.
Reset button	Reboots and initializes the system.
NMI button	Pressing the recessed button with a paper clip or pin puts the server in a halt state for diagnostic purposes and allows you to issue a non-maskable interrupt. After issuing the interrupt, a memory download can be performed to determine the cause of the problem.
ID button	Toggles the front panel ID LED and the baseboard ID LED on/off. The baseboard ID LED is visible through the rear of the chassis and allows you to locate the server you're working on from behind a rack of servers.
Chassis Intrusion Switch	A chassis intrusion switch is located on the interface board behind the front panel.

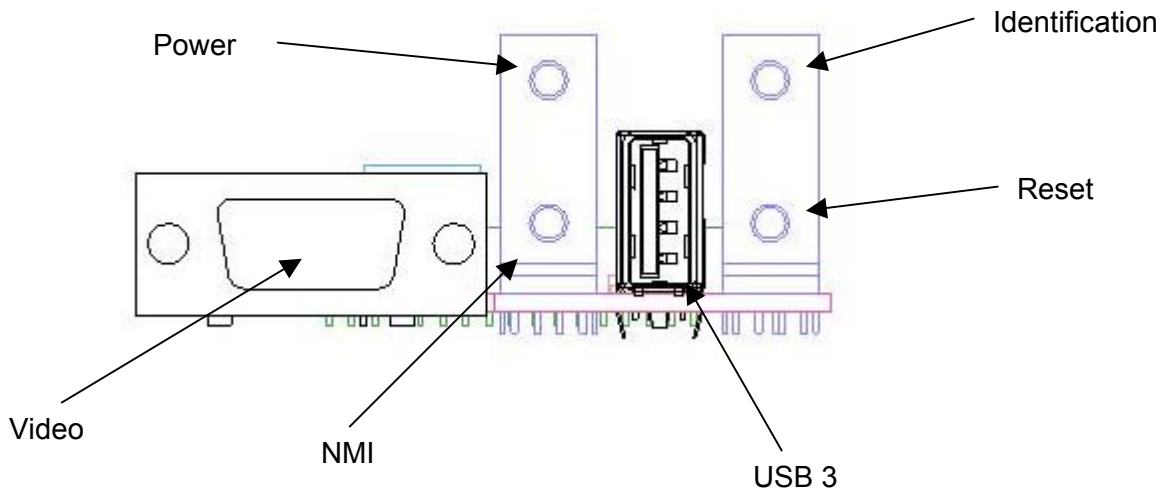

Figure 22. Front Panel Assembly Interface Board, Front View

5.2 Front Panel Assembly Connectors

The front panel assembly has two external I/O connectors:

- One USB port
- One VGA video port

The following tables provide the pin-outs for both types of connectors.

Table 11. External USB Connectors (J3)

Pin #	I/O	Description
1	USBPWR	VREG_FP_USBPWR3
2	I/O	USB_DM3_FP
3	I/O	USB_DP3_FP
4	PWR	GND

Table 12. Video Connector

Pin #	I/O	Description
1	O	Red
2	O	Green
3	O	Blue
4	O	No Connect
5	Pwr	GND
6	Pwr	GND
7	I	Video Switch
8	Pwr	GND
9		No Connect
10	Pwr	GND
11		No Connect
12		No Connect
13	O	Hsync
14	O	Vsync
15		No Connect

If a monitor is connected to the front panel video connector, the rear video port (on the server boards SE7500WV2 and SE7501WV2) will be disabled and the front panel video will be enabled. The video source is the same for both connectors and is switched between the two, with the front panel having priority over the rear video. This provides for easy front accessibility to the server.

The front panel assembly interface board also has two internal connectors:

- A 34-pin header provides control and status information to/from the baseboard through the hard disk drive backplane board.
- A 10-pin USB header provides control for one USB ports from the baseboard.

A 34-pin flat cable connects the front panel to the selected hard drive backplane. The backplane provides a signal path to a 100-pin connector, which is then cabled to the server baseboards SE7500WV2 and SE7501WV2.

Table 13. Internal USB Header (J2)

Pin #	I/O	Description
1	PWR	VREG_FP_USBPWR3
2	PWR	VREG_FP_USBPWR4
3	I/O	USB_DM3_FP
4	I/O	USB_DM4_FP
5	I/O	USB_DP3_FP
6	I/O	USB_DP4_FP
7	PWR	GND
8	PWR	GND
9	NC	KEY
10	NC	USB_FP_OC

Table 14. Front Panel (J1) to HDD Backplane Connector

Pin #	I/O	Description
1	NC	ZZ_V_SWITCH_L
2	NC	TP_FP34_P33
3	I	GND
4	O	V_IO_RED_CONN_FP
5	PWR	GND
6	I	V_IO_GREEN_CONN_FP
7	PWR	GND
8	I	V_IO_BLUE_CONN_FP
9	I	V_IO_HSYNC_BUFF_FP_L
10	I	V_IO_VSYNC_BUFF_FP_L
11	O	NIC2_LED_ON_ACTIVITY
12	I	FP_NMI_BTN_L
13	NC	NC_FP_RSV2
14	NC	NC_FP_KEY
15	O	NIC2_LED_3V_LINK_L
16	PWR	GND
17	I	CHASSIS_INTRUSION_L
18	I	ID_SW_ACTIVE_L
19	I/O	I2C_CLK
20	O	CLIFTON/GIFFORD_LED_CATHOD_L

Pin #	I/O	Description
21	I/O	I2C_DATA
22	I	RST_SW_ACTIVE_L
23	O	NIC1_LED_ON_ACTIVITY
24	O	HDD_LED_FAULT_L
25	O	NIC1_LED_3V_LINK_L
26	I	PWR_SW_ACTIVE_L
27	O	ID_LED_ON_L
28	O	HDD_LED_ON_L
29	PWR	SB5V
30	PWR	VCC
31	O	FP_SYS_FLT_LED2_L
32	O	POWER_LED_ON_L
33	I	FP_SYS_FLT_LED1_L
34	I	LED Anode for another Model

5.3 Front Panel System Status LED Indicators

The front panel houses six LEDs, which are viewable with or without the front bezel to display the system's operating state. The LEDs provide a status for the following system states:

- Power / sleep
- NIC1 / NIC2 activity
- System state
- Disk activity
- System identification

• Table 15. Front Panel LED Functions

LED	Color	State	Description
Power / Sleep (on standby power)	Green	On	Legacy power on / ACPI S0 state
		Blink ^{1,4}	Sleep / ACPI S1 state
	Off	Off	Power Off / ACPI S4 or S5 state
NIC1 / NIC2 Activity	Green	On	NIC Link
	Green	Blink	NIC Activity
System Status (on standby power)	Green	On	Running / normal operation
		Blink ^{1,2}	Degraded
	Amber	On	Critical or non-recoverable condition.
		Blink ^{1,2}	Non-critical condition.
Off	Off	POST / system stop.	
Disk Activity	Green	Random blink	Provides an indicator for disk activity.
	Off	Off ³	No hard disk activity
System Identification	Blue	On	Identify active via command or button.
	Off	Off	No Identification.

Notes:

1. Blink rate is ~1 Hz with at 50% duty cycle.
2. The amber status takes precedence over the green status. When the amber LED is on or blinking, the green LED is off.
3. Also off when the system is powered off (S4/S5) or in a sleep state (S1).
4. The power LED sleep indication is maintained on standby by the chipset. If the system is powered down without going through BIOS, the LED state in effect at the time of power off will be restored when the system is powered on until the BIOS clears it. If the system is not powered down normally, it is possible that the Power LED will be blinking at the same time that the system status LED is off due to a failure or configuration change that prevents the BIOS from running.

The current limiting resistors for the power LED, the system fault LED, and the NIC LEDs are located on the server boards SE7500WV2 and SE7501WV2.

5.3.1 Power / Sleep LED

The BIOS controls the front panel power LED as described in Table 16.

Table 16. SSI Power LED Operation

State	Power Mode	LED	Description
Power Off	Non-ACPI	Off	System power is off, and the BIOS has not initialized the chipset.
Power On	Non-ACPI	On	System power is on, but the BIOS has not yet initialized the chipset.
S5	ACPI	Off	Mechanical is off, and the operating system has not saved any context to the hard disk.

State	Power Mode	LED	Description
S4	ACPI	Off	Mechanical is off. The operating system has saved context to the hard disk.
S3-S1	ACPI	Slow blink ¹	DC power is still on. The operating system has saved context and gone into a level of low-power state.
S0	ACPI	Steady on	System and the operating system are up and running.

Notes:

1. Blink rate is ~ 1Hz with at 50% duty cycle.

5.3.2 System Status LED

5.3.2.1 Critical Conditions

A critical condition is any critical or non-recoverable threshold crossing associated with the following events:

- Temperature, voltage, or fan critical threshold crossing.
- Power subsystem failure. The BMC asserts this failure whenever it detects a power control fault (e.g., the BMC detects that the system power is remaining ON even though the BMC has deserted the signal to turn off power to the system).
- A hot-swap backplane would use the Set Fault Indication command to indicate when one or more of the drive fault status LEDs are asserted on the hot-swap backplane.
- The system is unable to power up due to incorrectly installed processor(s), or processor incompatibility.
- Satellite controller sends a critical or non-recoverable state, via the Set Fault Indication command to the BMC.
- Critical event logging errors, including: System Memory Uncorrectable ECC error, and fatal / uncorrectable bus errors such as PCI SERR and PERR.

5.3.2.2 Non-Critical Conditions

A non-critical condition is threshold crossing associated with the following events:

- Temperature, voltage, or fan non-critical threshold crossing.
- Chassis intrusion
- Satellite controller sends a non-critical state, via the Set Fault Indication command, to the BMC.
- Set Fault Indication command from system BIOS. The BIOS may use the Set Fault Indication command to indicate additional 'non-critical' status such as a system memory or CPU configuration changes.

5.3.2.3 Degraded Conditions

A degraded condition is associated with the following events:

- Non-redundant power supply operation. This applies only when the BMC is configured for a redundant power subsystem.
- One or more processors are disabled by Fault Reliant Booting (FRB) or BIOS.
- BIOS has disabled or mapped out some of the system memory.

5.3.3 Drive Activity LED

The drive activity LED on the front panel indicates drive activity from the onboard hard disk controllers. The server boards SE7500WV2 and SE7501WV2 also provides a header giving access to this LED for add-in controllers.

5.3.4 System Identification LED

The blue system identification LED is used to help identify a system for servicing. This is especially useful when the system is installed when in a high density rack or cabinet that is populated with several similar systems. The system ID LED is illuminated when the System ID button on the front panel is pressed or it can be illuminated remotely through server management software.

6. Hot-Swap SCSI Backplane

The SR2300 server chassis can support a multifunctional SCSI Backplane, supporting the following features:

- Seven SCA-2 compatible hot-swap SCSI connectors, capable of supporting either seven SCA HDDs, or six SCA HDDs and a Floppy/CDROM Module.
- Support for the following SCSI bus specifications: Ultra-2, and Ultra-160
- Active SCSI termination (SPI-4 compatible)
- Support for LVD operations
- Per-drive power control, including automatic slot power-down upon drive removal
- SAF-TE 1.0 compliant, enclosure management and monitoring functions
- Provides a pathway for front panel, ATA-100, and floppy signals from the baseboard to the appropriate connectors

6.1 Hot-Swap SCSI Backplane Board Layout

The Hot-Swap SCSI Backplane resides on the back of the hot-swap drive bay of the SR2300 server chassis.

The following diagram shows the layout of components and connectors on the Hot-swap SCSI Backplane printed circuit board.

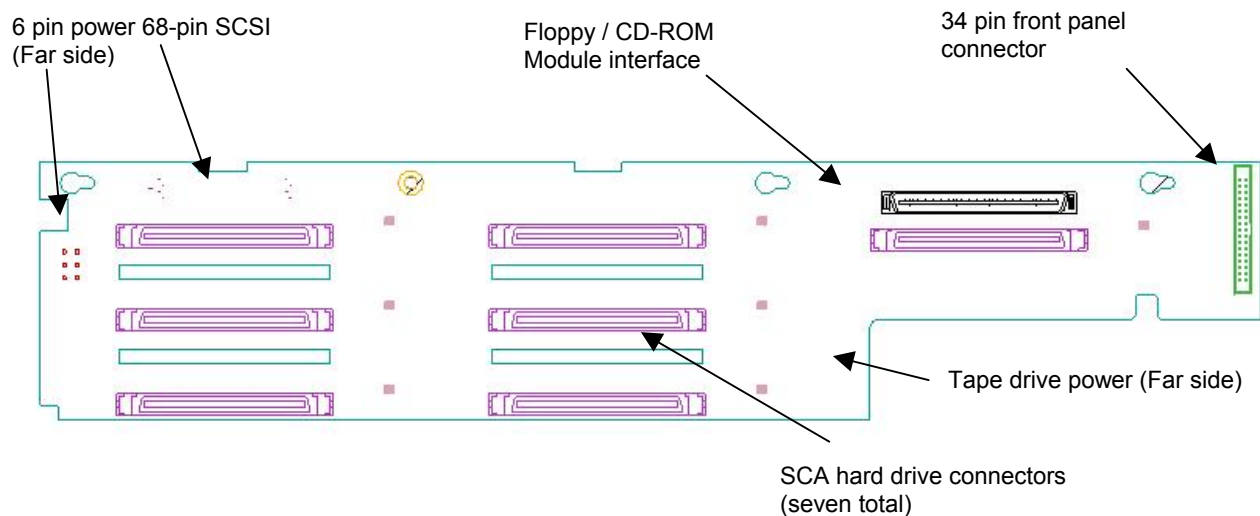

Figure 23. Component Side Hot-Swap SCSI Backplane Connector Placement

6.2 SCSI Backplane Functional Architecture

The SCSI backplane functions begin at power-up. The microprocessor boots up via code residing in the FLASH boot block. The SCSI backplane is capable of downloading firmware via the IMB to update the FLASH executable code.

The following figure shows the functional blocks of the hot-swap SCSI backplane.

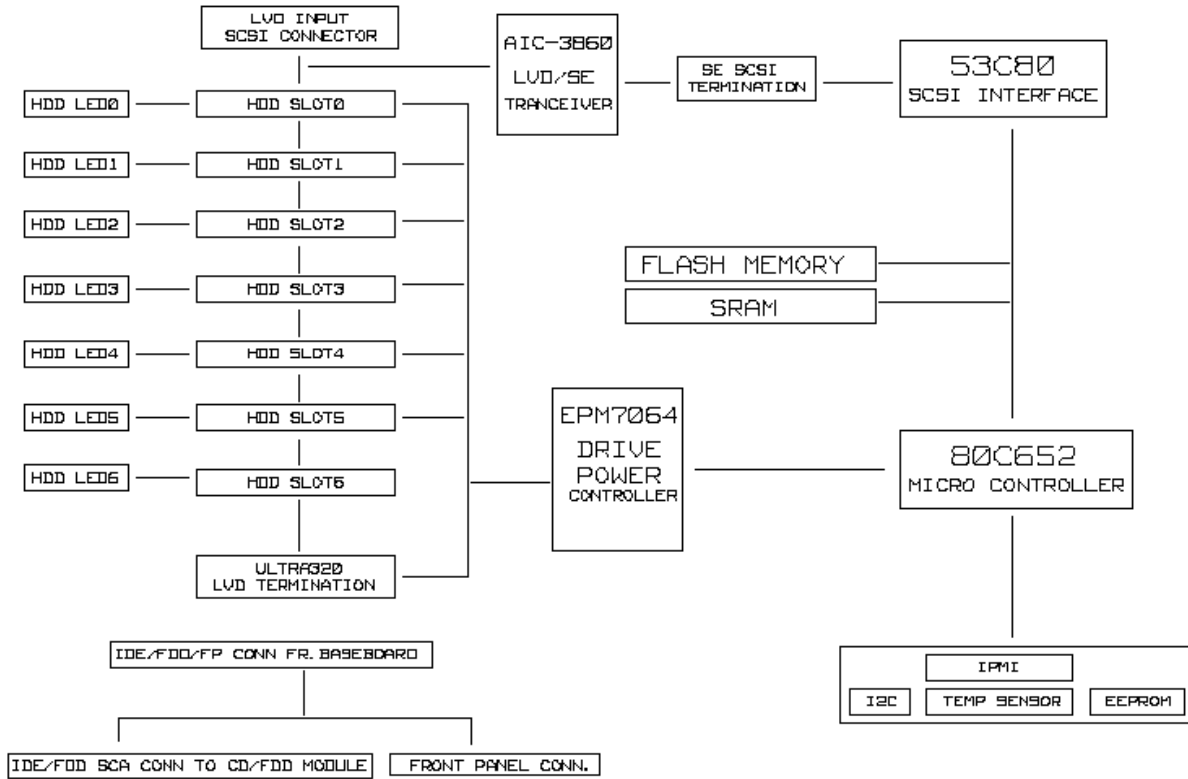

Figure 24. SCSI Backplane Block Diagram

6.2.1 Resets

The SCSI backplane is capable of supporting two types of resets. A cold reset, which occurs when system power is cycled, and a SCSI bus reset, which occurs when the microcontroller receives a "Reset" SAF-TE command.

6.2.2 Phillips* P80C652FBB Microcontroller

The SCSI backplane supports the SAF-TE 1.0 specification and utilizes the Philips P80C652FBB microcontroller for all SAF-TE functions. If necessary, the backplane can function without the SAF-TE microcontroller as a simple interconnection for the SCSI drives and termination in LVD or SE mode.

P80C652FBB features include:

- Operating frequency is 12 MHz
- 80C51-based architecture
- Four 8-bit I/O ports
- Two 16-bit timer/counters
- Full-duplex UART facilities
- I²C serial interface
- Two power control modes: idle mode and power-down mode
- Operating temperature range: 0°C to +70°C

6.2.2.1 I²C Serial Communication-SI01

The I²C pins are alternate functions to port pins P1.6 and P1.7. Because of this, P1.6 and P1.7 on these parts do not have a pull-up structure as found of the 80C51. Therefore, P1.6 and P1.7 have open drain outputs on the 80C652.

6.2.2.2 I²C Electrical Input/Output Specifications

The I²C bus allows communication between devices made from different technologies, which might also use different supply voltages.

For devices with fixed input levels, operating on a supply voltage of +5V ±10%, the following levels have been defined:

- $V_{ILmax} = 1.5V$ (maximum input low voltage)
- $V_{IHmin} = 3V$ (minimum input High voltage)

Devices operating on a fixed supply voltage different from +5V (e.g. I²L), must also have these input levels of 1.5V and 3V for V_{IL} and V_{IH} respectively.

For devices operating over a wide range of supply voltages (e.g. CMOS), the following levels have been defined:

- $V_{ILmax} = 0.3V_{DD}$ (maximum input Low voltage)
- $V_{IHmin} = 0.7V_{DD}$ (minimum input High voltage)

For both groups of devices, the maximum output Low value has been defined:

- $V_{OLmax} = 0.4V$ (max. output voltage Low) at 3mA sink current

The maximum low-level input current at V_{OLmax} of both the SDA pin and the SCL pin of an I²C device is -10uA, including the leakage current of a possible output stage.

The maximum high-level input current at $0.9V_{DD}$ of both the SDA pin and SCL pin of an I²C device is 10uA, including the leakage current of a possible output stage.

The maximum capacitance of both the SDA pin and the SCL pin of an I²C device is 10pf.

6.2.2.3 Noise Margin

- Noise margin minimum on the Low level is $0.1 V_{DD}$
- Noise margin minimum on the High level is $0.2 V_{DD}$

6.2.3 Symbios* SYM53C80S SCSI Controller

The SCSI backplane uses a Symbios SYM53C80S controller to perform all SCSI functions. Device selection is memory-mapped at address FB00-FC00. It is reset on power-up and when reset is asserted to the backplane. SYM53C80S access slows the bus, so it is recommended that SAF-TE be pulsed infrequently. SAF-TE command processing is 2 - 10ms.

The SYM53C80S supports the following features:

- The ANSI X3.131-1994 standard
- Parity generation with optional checking
- No external clock required
- On-chip 48mA single-ended drivers and receivers
- Functions in both the target and initiator roles
- Direct control of all SCSI signals
- Asynchronous data transfers of up to 5.0 MB/second.
- Variety of packaging options
- SCSI protocol efficiency is directly proportional to the speed of the microprocessor
- CMOS parts provide additional grounding and controlled fall times that reduce noise generated by SCSI bus switching
- SCAM Level 1 and 2 compatibility

6.2.4 SCSI Interface

The SCSI interface on the SR2300 Hot-swap SCSI Backplane provides the required circuitry between the SCSI bus and the 80C652 microcontroller. This allows the microcontroller to respond as a SCSI target. The interface consists of a Symbios 53C80S SCSI Interface Chip, which functions as translator between the SCSI bus and the microcontroller. The 53C80S is a single-ended, narrow device.

6.2.5 LVD to SE Bridge

Since the 53C80S is a single-ended, narrow device, an Adaptec* AIC-3860 LVD-to-SE Transceiver (Bridge) is used to create a single-ended extension of the LVD bus. This allows the 53C80S to communicate with the LVD bus.

6.2.6 SCSI Termination

Passive SE termination is used for the single-ended extension of the SCSI bus on which the 53C80S resides.

LVD/SE multi-mode terminators provide SPI-4 compliant active termination for the backplane end of the SCSI bus. It is assumed that the other end of the SCSI segment is properly terminated as required by the SPI-4 specification. Multi-mode termination is implemented on the

SR2300 Hot-swap SCSI Backplane using two Unitrode* UCC5638 Multi-mode SCSI 15 line terminators.

6.2.7 Power Control

Power control on the SR2300 hot-swap SCSI backplane supports the following features:

- Power-down of a drive when a failure is detected and reported (using enclosure services messages) via the SCSI bus. This decreases the likelihood that the drive is damaged during removal from the hot-swap drive bay. When a new drive is inserted, the power control waits a short amount of time for the drive to be fully seated before applying power to the drive.
- If the system power is on, the Hot-swap SCSI Backplane immediately powers off a drive slot when it detects that a drive has been removed. This prevents possible damage to the drive when it is partially removed and re-inserted while full power is available, and prevents disruption of the entire SCSI array from possible sags in supply voltage and resultant current spikes.
- Hot-spare drive support: Spare drives remain in the hot-swap bay, but are left un-powered until a drive is determined to have failed. In case of a drive failure, the hot spare can be powered up and put into service automatically without requiring immediate operator intervention to replace the drive.
- The hot-swap SCSI backplane will automatically bypass the power control circuitry if a shorted drive is inserted or if a drive develops a short during operation. This prevents the hot-swap SCSI backplane from being damaged by a drive that draws excessive current.

6.3 Power Connector

The SCSI backplane provides power to the seven drive bays, supporting up to seven hard disk drives, or six hard disk drives and the optional Floppy/CDROM Module. A 6-pin power cable is routed from the Power Distribution Board and plugs into 2x3 shrouded plastic PC power connector on the SCSI backplane. The following table shows the power connector pin-out.

Table 17. SCSI Backplane Power Connector Pin-out

Pin	Name	Pin	Name
1	GND	4	+12V
2	GND	5	+12V
3	+5V	6	+3.3V

6.3.1 Power Requirements

The Hot-swap SCSI backplane provides power to up to seven peripherals. The integrator should refer to the specific hard drive specification for power requirements. A typical 18 W drive would require approximately 0.9A of +5V and 1.1A of +12V.

Table 18. Power Requirements

# of Typical Hard Drives	Total 5V Current (amps)	Total 12V current (amps)	Total drive power (watts)
1	0.9	1.1	17.7
2	1.8	2.2	35.4
3	2.7	3.3	53.1
4	3.6	4.4	70.8
5	4.5	5.5	88.5
6	5.4	6.6	106.2
7	6.3	7.7	123.9

6.3.2 Drive Activity / Fault LEDs

The SCSI backplane provides Drive Activity/Fault LED Indicators, mounted near each SCA-2 connector. The driving circuitry is entirely contained on the backplane. The drive fault LEDs are activated by the microcontroller, and indicate a failure status for each drive. During initialization, the microcontroller flashes the LEDs for one second as part of POST.

6.3.3 Internal Management Bus (IMB)

The Internal Management Bus is a system-wide server management bus, based on the Phillips* I²C* bus specification. It provides a way for various system components to communicate independently of the standard system interfaces (e.g., PCI bus or processor/memory bus). The I²C bus controller is integrated into the microcontroller. IMB connectivity is provided to the SCSI backplane via the front panel connector.

6.3.4 Local I²C EEPROM and Temperature Sensor

An I²C bus temperature sensor is connected to the microcontroller on a private I²C bus. Microcontroller programming implements the private I²C connection by explicitly setting and clearing appropriate clock and data signals, to emulate an I²C-like interface to the sensor. Temperature information is made available to other devices in the chassis using Enclosure Services messages. A Dallas* DS1624 Serial EEPROM/Temperature Sensor implements this function. The EEPROM stores the Field Replaceable Unit (FRU) information for the backplane.

6.4 SCA2 Hot-Swap Connectors

The SCSI Backplane provides seven hot-swap SCA2 connectors that provide power and SCSI signals using a single connector. Each SCA drive attaches to the backplane using one of these connectors.

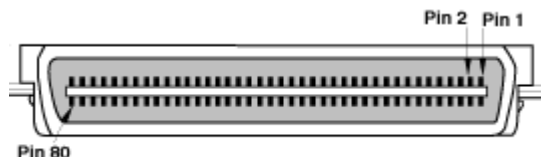

Figure 25. 80-pin SCA2 Connector

6.5 Baseboard to SCSI Interconnect

A 68-pin SCSI cable is used to interface the SCSI backplane with either the on-board SCSI channel of the server boards SE7500WV2 and SE7501WV2 or an add-in PCI SCSI controller installed on the PCI riser card.

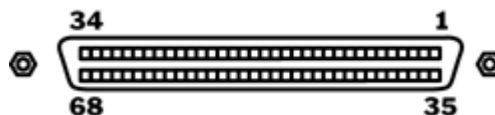

Figure 26. 68-pin SCSI Cable Connector

Table 19. Ultra2 (LVD) SCSI Connector Pin-out

Pin	Name	Pin	Name	Pin	Name	Pin	Name
1	+DB (12)	18	TERMPWR	35	-DB (12)	52	TERMPWR
2	+DB (13)	19	RESERVED	36	-DB (13)	53	RESERVED
3	+DB (14)	20	GROUND	37	-DB (14)	54	GROUND
4	+DB (15)	21	+ATN	38	-DB (15)	55	-ATN
5	+DB (P1)	22	GROUND	39	-DB (P1)	56	GROUND
6	+DB (0)	23	+BSY	40	-DB (0)	57	-BSY
7	+DB (1)	24	+ACK	41	-DB (1)	58	-ACK
8	+DB (2)	25	+RST	42	-DB (2)	59	-RST
9	+DB (3)	26	+MSG	43	-DB (3)	60	-MSG
10	+DB (4)	27	+SEL	44	-DB (4)	61	-SEL
11	+DB (5)	28	+C/D	45	-DB (5)	62	-C/D
12	+DB (6)	29	+REQ	46	-DB (6)	63	-REQ

Pin	Name	Pin	Name	Pin	Name	Pin	Name
13	+DB (7)	30	+I/O	47	-DB (7)	64	-I/O
14	+DB (P)	31	+DB (8)	48	-DB (P)	65	-DB (8)
15	GROUND	32	+DB (9)	49	GROUND	66	-DB (9)
16	DIFFSENS	33	+DB (10)	50	GROUND	67	-DB (10)
17	TERMPWR	34	+DB (11)	51	TERMPWR	68	-DB (11)

6.6 Server Baseboards SE7500WV2 and SE7501WV2 to CD/FDD/FP/Video Interface

The SCSI backplane provides a pathway for the Floppy, Front Panel, IDE and video signals from the server boards SE7500WV2 and SE7501WV2 to the floppy / CD-ROM module interface connector and front panel connector. The following table provides the pin-out for the 100-pin (JAEE*: WR-100S-VF-1) connector.

Table 20. Floppy / FP / IDE Connector Pin-out

Pin	Name	Pin	Name
A1	GND	B1	V_RED
A2	GND	B2	V_GREEN
A3	GND	B3	V_BLUE
A4	V_HSYNC_L	B4	V_VSYNC_L
A5	NIC2_LED_ON_ACTIVITY	B5	FP_NMI_BTN_L
A6	NIC2_LED_3V_LINK_L	B6	GND
A7	CHASSIS_INTRUSION	B7	ID_SW_ACTIVE_L
A8	I2C_CLK	B8	+5V STANDBY
A9	I2C_DATA	B9	RST_SW_ACTIVE_L
A10	NIC1_LED_ON_ACTIVITY	B10	HDD_LED_FAULT_L
A11	NIC1_LED_3V_LINK_L	B11	PWR_SW_ACTIVE_L
A12	ID_LED_ON_L	B12	HDD_LED_ON_L
A13	+5V STANDBY	B13	VCC
A14	FP_SYS_FLT_LED2_L	B14	POWER_LED_ON_L
A15	FP_SYS_FLT_LED1_L	B15	+5V STANDBY
A16	IPMB_5VSB_SCL	B16	RST_P6_PWR_GOOD
A17	GND	B17	IPMB_5VSB_SDA
A18	FDD_HDSEL_L	B18	GND
A19	GND	B19	FDD_DSKCHG_L
A20	FDD_RDATA_L	B20	FDD_WPROT_L
A21	GND	B21	FDD_TRK0_L
A22	FDD_WDATA_L	B22	GND
A23	GND	B23	FDD_WGATE_L
A24	FDD_STEP_L	B24	FDD_DIR_L
A25	GND	B25	FDD_DS0_L
A26	FDD_MTR0_L	B26	GND

Pin	Name	Pin	Name
A27	GND	B27	FDD_INDEX_L
A28	V_SWITCH_L	B28	GND
A29	GND	B29	FDD_DENSEL0
A30	CHP3_CDRST_L	B30	GND
A31	GND	B31	CDR_D7
A32	CDR_D8	B32	CDR_D6
A33	CDR_D9	B33	GND
A34	GND	B34	CDR_D5
A35	CDR_D10	B35	CDR_D4
A36	CDR_D11	B36	GND
A37	GND	B37	CDR_D3
A38	CDR_D12	B38	CDR_D2
A39	CDR_D13	B39	GND
A40	GND	B40	CDR_D1
A41	CDR_D14	B41	CDR_D0
A42	CDR_D15	B42	GND
A43	GND	B43	CDR_DREQ
A44	CDR_IOW_L	B44	GND
A45	CDR_IOR_L	B45	CDR_DACK_L
A46	CDR_IRDY	B46	GND
A47	CDR_IRQ	B47	CDR_ADDR1
A48	CDR_ADDR2	B48	CDR_ADDR0
A49	GND	B49	CDR_CS1_L
A50	CDR_CS3_L	B50	

6.7 Floppy/CDROM Module Connector

An 80-pin SCA-2 connector supports the optional Floppy/CD-ROM peripheral module. Through this connector, the CD-ROM and FDD signals are interfaced to the respective units.

The use of SCSI drives on this connector is not supported. The mechanical design of the hard drive bay and the gender of the SCA2 connector prevents a SCSI HDD from being inserted into this peripheral connector. The following table shows the pin-out for the peripheral connector.

Table 21. 80-pin peripheral connector pin-out

Pin	Name	Pin	Name
1	N.C.	41	GND
2	N.C.	42	GND
3	N.C.	43	GND
4	N.C.	44	CD_FDD_PRSN_L
5	N.C.	45	CDR_DREQ

Pin	Name	Pin	Name
6	N.C.	46	N.C.
7	CDR_CS3_L	47	CDR_CS1_L
8	CDR_ADDR2	48	CDR_ADDR0
9	CDR_DACK_L	49	CDR_ADDR1
10	CDR_IRQ	50	CDR_IRDY
11	CDR_IOR_L	51	CDR_IOW_L
12	CDR_D15	52	CDR_D0
13	CDR_D14	53	CDR_D1
14	CDR_D13	54	CDR_D2
15	CDR_D12	55	CDR_D3
16	CDR_D11	56	CDR_D4
17	CDR_D10	57	CDR_D5
18	CDR_D9	58	CDR_D6
19	CDR_D8	59	CDR_D7
20	CHP3_CDRST_L	60	FDD_INDEX_L
21	FDD_DSKCHG_L	61	FDD_DIR_L
22	FDD_WDATA_L	62	FDD_DENSEL0
23	FDD_TRK0_L	63	FDD_DS0_L
24	FDD_RDATA_L	64	FDD_MTR0_L
25	FDD_STEP_L	65	FDD_WGATE_L
26	FDD_WPROT_L	66	FDD_HDSEL_L
27	N.C.	67	N.C.
28	N.C.	68	N.C.
29	N.C.	69	N.C.
30	N.C.	70	N.C.
31	N.C.	71	N.C.
32	N.C.	72	N.C.
33	N.C.	73	N.C.
34	+5V	74	CD_FDD_PRSN_L
35	+5V	75	GND
36	+5V	76	GND
37	N.C.	77	ACTIVE6_L
38	GND	78	N.C.
39	N.C.	79	N.C.
40	N.C.	80	N.C.

6.8 Front Panel Interface Connector

The SCSI backplane provides a pathway for front panel signals from the 100-pin floppy / FP / IDE connector to the front panel connector (WY* BHS-33A-2.0D-SM). The pin-out for the FP connector is shown in the following table.

Table 22. SCSI Backplane FP Connector Pin-out

Pin	Name	Pin	Name
1	GND	2	FP_SYS_FLT_LED1_L
3	POWER_LED_ON_L	4	FP_SYS_FLT_LED2_L
5	VCC	6	SB5V
7	HDD_LED_ON_L	8	ID_LED_ON_L
9	PWR_SW_ACTIVE_L	10	NIC1_LED_3V_LINK_L
11	HDD_LED_FAULT_L	12	NIC1_LED_ON_ACTIVITY
13	RST_SW_ACTIVE_L	14	I2C_DATA
15	GND	16	I2C_CLK
17	ID_SW_ACTIVE_L	18	CHASSIS_INTRUSION
19	GND	20	NIC2_LED_3V_LINK_L
21	KEY	22	RESERVED 2
23	FP_NMI_BTN_L	24	NIC2_LED_ON_ACTIVITY
25	EMP_DSR2_L	26	EMP_INUSE_L
27	EMP_SIN2	28	EMP_SOUT2
29	EMP_RTS2_L	30	EMP_CTS2_L
31	EMP_DTR2_L	32	EMP_DCD2_L
33	RESERVED 1	34	RESERVED 3

7. Floppy/CDROM and Floppy/DVD Module Interface Assemblies

For system configurations that require a floppy drive and a CD-ROM or DVD drive, an optional Floppy/CDROM or Floppy/DVD drive module can be used. This module plugs into the flex bay (Drive bay closest to the front panel) in the front of the chassis.

The module has an interface board, which provides blind mate attachment with the SCSI backplane. The interface board provides both ATA100 and floppy drive signals.

The module supports the following features:

- ATA100 signal path from the SCA connector to the CD-ROM or DVD drive
- FDD signal path from the SCA connector to the floppy drive

7.1 CD-ROM Signal Interface

The CD-ROM (ATA33) signal interface uses a 40-pin high-density connector (Molex* 54132-4090). The connector pin-out is shown below.

Table 23. CD-ROM (ATA33) Interface Connector (J2) Pin-out

Pin	Signal Name	Signal Name	Pin
1	GND	GND	21
2	GND	GND	22
3	CDR_DREQ	CDR_D (15)	23
4	GND	CDR_D (0)	24
5	VCC	CDR_D (14)	25
6	GND	CDR_D (1)	26
7	VCC	CDR_D (13)	27
8	CDR_CS1_L	CDR_D (2)	28
9	VCC	CDR_D (12)	29
10	CDR_ADDR0	CDR_D (3)	30
11	VCC	CDR_D (11)	31
12	CDR_ADDR1	CDR_D (4)	32
13	VCC	CDR_D (10)	33
14	CDR_IRQ	CDR_D (5)	34
15	CDR_DACK_L	CDR_D (9)	35
16	CDR_IRDY	CDR_D (6)	36
17	CDR_CS3_L	CDR_D (8)	37
18	CDR_IOR_L	CDR_D (7)	38
19	CDR_ADDR2	RESERVED	39
20	CDR_IOW_L	CHP3_CDRST_L	40

7.1.1 FDD Signal Interface

The floppy signal interface uses a 20-pin high density connector (Molex 52271-2690). The connector pin-out is shown below.

Table 24. FDD Interface Connector (J1) Pin-out

Pin	Signal Name	Signal Name	Pin
1	VCC	FDD_STEP_L	14
2	FDD_INDEX_L	GND	15
3	VCC	FDD_WDATA_L	16
4	FDD_DS0_L	GND	17
5	VCC	FDD_WGATE_L	18
6	FDD_DSKCHG_L	GND	19
7	NC	FDD_TRK0_L	20
8	NC	GND	21
9	NC	FDD_WPROT_L	22
10	FDD_MTR0_L	GND	23
11	NC	FDD_RDATA_L	24
12	FDD_DIR_L	GND	25
13	FDD_DENSEL_0	FDD_HDSEL_L	26

7.1.2 CD/FDD Signal Interface

The CD/FDD module signal interface uses an 80-pin SCA2 male connector (AMP* 1123283-9). The connector pin-out is shown below.

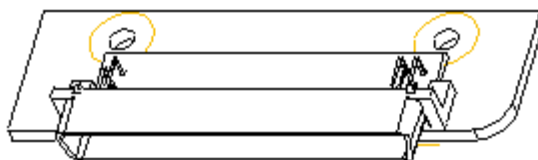

Figure 27. Floppy/CDROM Daughter Board

Table 25. SCA2 CD/FDD Interface Connector (J3) Pin-out

Pin	Signal Name	Signal Name	Pin
1	NC	GND	41
2	NC	GND	42
3	NC	GND	43
4	NC	GND (Drive Present Signal ON)	44

Pin	Signal Name	Signal Name	Pin
5	NC	CDR_DREQ	45
6	NC	NC	46
7	CDR_CD3_L	CDR_CS1_L	47
8	CDR_ADDR2	CDR_ADDR0	48
9	CDR_DACK_L	CDR_ADDR1	49
10	CDR_IRQ	CDR_IRDY	50
11	CDR_IOR_L	CDR_IOW_L	51
12	CDR_D (15)	CDR_D (0)	52
13	CDR_D (14)	CDR_D (1)	53
14	CDR_D (13)	CDR_D (2)	54
15	CDR_D (12)	CDR_D (3)	55
16	CDR_D (11)	CDR_D (4)	56
17	CDR_D (10)	CDR_D (5)	57
18	CDR_D (9)	CDR_D (6)	58
19	CDR_D (8)	CDR_D (7)	59
20	CHP3_CDRST_L	FDD_INDEX_L	60
21	FDD_DSKCHG_L	FDD_DIR_L	61
22	FDD_WDATA_L	FDD_DENSEL0	62
23	FDD_TRK0_L	FDD_DS0_L	63
24	FDD_RDATA_L	FDD_MTR0_L	64
25	FDD_STEP_L	FDD_WGATE_L	65
26	FDD_WPROT_L	FDD_HDSEL_L	66
27	For IDE HSBP Power Control	NC	67
28	For IDE HSBP Power Control	NC	68
29	NC	NC	69
30	NC	NC	70
31	NC	NC	71
32	NC	NC	72
33	NC	NC	73
34	VCC	GND (Drive Present Signal ON)	74
35	VCC	GND	75
36	VCC	GND	76
37	NC	10K Pull-up (Disable DISK ACT LED)	77
38	NC	NC	78
39	NC	NC	79
40	NC	NC	80

7.2 CD-ROM/DVD Adapter Board

The slim-line CD-ROM or DVD drive within the Floppy/CDROM or Floppy/DVD module has a separate interface board connecting the drive to the module.

7.2.1 CD-ROM/DVD Signal Interface

The CD-ROM (ATA33) signal interface has two connectors, a 40-pin high density connector (Molex 52559-4092) and 50-pin high density connector (JAE* Kx14-50K5D1). The connector pin-outs are shown below.

Table 26. CD-ROM (ATA33) Interface Connector (J1) Pin-out (CD/FDD Board Side)

Pin	Name	Name	Pin
1	CHP3_CDRST_L	CDR_IOW_L	21
2	NC	CDR_ADDR2	22
3	CDR_D (7)	CDR_IOR_L	23
4	CDR_D (8)	CDR_CS3_L	24
5	CDR_D (6)	CDR_IRDY	25
6	CDR_D (9)	CDR_DACK_L	26
7	CDR_D (5)	CDR_IRQ	27
8	CDR_D (10)	VCC	28
9	CDR_D (4)	CDR_ADDR1	29
10	CDR_D (11)	VCC	30
11	CDR_D (3)	CDR_ADDR0	31
12	CDR_D (12)	VCC	32
13	CDR_D (2)	CDR_CS1_L	33
14	CDR_D (13)	VCC	34
15	CDR_D (1)	GND	35
16	CDR_D (14)	VCC	36
17	CDR_D (0)	GND	37
18	CDR_D (15)	CDR_DREQ	38
19	GND	GND	39
20	GND	GND	40

7.2.2 FDD Signal Interface

The FDD signal interface uses a 20-pin high density connector (JAEE: Kx14-50K5D1). The connector pin-out is shown below.

Table 27. CD-ROM (ATA33) Interface Connector (J2) Pin-out (CD-ROM Side)

Pin	Name	Name	Pin
1	NC	GND	26
2	NC	CDR_IRDY	27
3	NC	CDR_DACK_L	28
4	NC	CDR_IRQ	29
5	CHP3_CDRST_L	1K Pull-Down	30
6	CARD (8)	CDR_ADDR1	31
7	CARD (7)	1K Pull-Down	32
8	CARD (9)	CDR_ADDR0	33
9	CARD (6)	CDR_ADDR2	34
10	CARD (10)	CDR_CS1_L	35
11	CARD (5)	CDR_CS3_L	36
12	CARD (11)	NC	37
13	CARD (4)	VCC	38
14	CARD (12)	VCC	39
15	CARD (3)	VCC	40
16	CARD (13)	VCC	41
17	CARD (2)	VCC	42
18	CARD (14)	GND	43
19	CARD (1)	GND	44
20	CARD (15)	GND	45
21	CARD (0)	GND	46
22	CDR_DREQ	HDSEL (NC)	47
23	GND	GND	48
24	CDR_IOR_L	NC	49
25	CDR_IOW_L	NC	50

8. PCI Riser Cards

The SR2300 2U server chassis supports the use of two 3-slot PCI riser cards. Each riser card is capable of supporting a 3.3-volt, 64-bit PCI add-in card. Due to component placement requirements on the server boards SE7500WV2 and SE7501WV2, the PCI riser card that is in the riser slot located closest to the edge of the baseboard will only support low-profile add-in cards. The second riser card supports both low-profile and full-height/full length PCI cards. Low profile cards this riser require full height I/O brackets.

Table 28. Max conditions for PCI Riser Cards

Configuration	Bus B with Anvik Dual Nic down and 3 Slot Riser	Bus C with 7899 SCSI down and 3 Slot Riser	Bus C with 7902 SCSI down and 3 Slot Riser
0 Adapter Cards installed and on board device enabled	PCI-X 64/100	PCI-X 64/66	PCI-X 64/100
1 Adapter Card installed and on board device enabled	PCI-X 64/100	PCI-X 64/66	PCI-X 64/100
2 Adapter Card installed and on board device enabled	PCI-X 64/66	PCI-X 64/66	PCI-X 64/100
3 Adapter Card installed and on board device enabled	PCI-X 64/66	PCI-X 64/66	PCI-X 64/66

The following table provides the pin-out of the 64-bit PCI connector.

Table 29. 3V 64-bit PCI Connector Pin-out

Pin	Side B	Side A	Pin	Side B	Side A
1	-12V	TRST#	49	M66EN	AD [09]
2	TCK	+12V	50	Ground	Ground
3	Ground	TMS	51	Ground	Ground
4	TDO	TDI	52	AD [08]	C/BE [0]#
5	+5V	+5V	53	AD [07]	+3.3V
6	+5V	INTA#	54	+3.3V	AD [06]
7	INTB#	INTC#	55	AD [05]	AD [04]
8	INTD#	+5V	56	AD [03]	Ground
9	PRSNT1#	Reserved	57	Ground	AD [02]
10	Reserved	+3.3V (I/O)	58	AD [01]	AD [00]
11	PRSNT2#	Reserved	59	+3.3V (I/O)	+3.3V (I/O)
12	CONNECTOR KEY	CONNECTOR KEY	60	ACK64#	REQ64#
13	CONNECTOR KEY	CONNECTOR KEY	61	+5V	+5V
14	Reserved	Reserved	62	+5V	+5V
15	Ground	RST#		CONNECTOR KEY	CONNECTOR KEY
16	CLK	+3.3V (I/O)		CONNECTOR KEY	CONNECTOR KEY
17	Ground	GNT#	63	Reserved	Ground
18	REQ#	Ground	64	Ground	C/BE [7]#
19	+3.3V (I/O)	Reserved	65	C/BE [6]#	C/BE [5]#
20	AD [31]	AD [30]	66	C/BE [4]#	+3.3V (I/O)
21	AD [29]	+3.3V	67	Ground	PAR64
22	Ground	AD [28]	68	AD [63]	AD [62]
23	AD [27]	AD [26]	69	AD [61]	Ground
24	AD [25]	Ground	70	+3.3V (I/O)	AD [60]
25	+3.3V	AD [24]	71	AD [59]	AD [58]
26	C/BE [3]#	IDLES	72	AD [57]	Ground
27	AD [23]	+3.3V	73	Ground	AD [56]
28	Ground	AD [22]	74	AD [55]	AD [54]
29	AD [21]	AD [20]	75	AD [53]	+3.3V (I/O)
30	AD [19]	Ground	76	Ground	AD [52]
31	+3.3V	AD [18]	77	AD [51]	AD [50]
32	AD [17]	AD [16]	78	AD [49]	Ground
33	C/BE [2]#	+3.3V	79	+3.3V (I/O)	AD [48]
34	Ground	FRAME#	80	AD [47]	AD [46]
35	IRDY#	Ground	81	AD [45]	Ground
36	+3.3V	TRDY#	82	Ground	AD [44]
37	DEVSEL#	Ground	83	AD [43]	AD [42]

9. Supported Intel® Server Boards

The SR2300 2U server chassis is designed to support the feature requirements of the Intel® server boards SE7500WV2 and SE7501WV2. Please refer to the SE7500WV2 Technical Product Specification and the SE7501WV2 Technical Product Specification for additional baseboard information. It will support the following feature set:

- Dual Intel® Xeon processors socket 604
- Intel® E7500 chipset or Intel E7501 chipset.
- Support for six DDR 200 or DDR266 Registered ECC memory with two-way interleaving up to 12GB's.
- Three separate PCI buses:
 - Segment A: 32-bit, 33 MHz, 5 V (P32-A) with four embedded devices:
 - 2D/3D graphics controller: ATI RAGE* XL video controller with 8 MB of SDRAM
 - ATA-100 controller: Promise Technology* PDC20277 (*ATA-100 SE7500WV2 and SE7501WV2 server boards only*)
 - Segment B: 64-bit, 100MHz, 3.3 V, (P64-B) supporting the following configuration:
 - Three PCI I/O riser slots capable of supporting full height / full length PCI add-in cards
 - Two network interface controllers: Intel® 82546PM Fast Ethernet Controllers
 - Segment C: 64-bit, 100MHz, 3.3 V (P64-C) supporting the following device:
 - Three PCI I/O riser slots, with support for low-profile PCI add-in cards only
 - Dual-channel wide Ultra-160 or Ultra- 320 SCSI controller providing one internal and one high density external channel support: Adaptec* AIC-7899W or Adaptec AIC-7902 SCSI Controller (SCSI SE7500WV2 and SE7501WV2 server boards only)
- LPC (Low Pin Count) bus segment with two embedded devices:
 - Platform Management Controller (PMC) providing monitoring, alerting, and logging of critical system information obtained from embedded sensors on server board
 - Super I/O controller chip providing all PC-compatible I/O (floppy, serial, keyboard, mouse)
- X-Bus segment with one embedded device:
 - Flash ROM device for system BIOS: Intel® 32-megabit 28F320C3 Flash ROM
- Two external Universal Serial Bus (USB) ports on the rear of the board with an additional internal header that provides one optional USB port for front panel support
- One external low-profile RJ45 Serial B port on the back of the board. An internal header is available providing an optional Serial A port.
- Support for up to 4 multi-speed fans and 2 fixed speed fans.
- High density connectors for 2U chassis design support: front panel, floppy, ATA.
- SSI compliant connectors for SSI interface support: front panel, floppy, ATA.

10. Serial Port Usage

The SR2300 server chassis, when integrated with either a server boards SE7500WV2 and SE7501WV2, provides one external RJ45 serial port (Serial B) and one optional DB9 serial port (Serial A) cabled from the SE7500WV2 or SE7501WV2 to the DB9 cutout in the rear chassis bulkhead. The Serial A cable is included as a part of the RS232 to DB9 dongle accessory.

The use of RJ45 connectors for the serial interface is widely becoming a standard for use in the high-density server market. The intended usage model for the RJ45 serial connector is for use as an interface to a serial port concentrator allowing for remote access to the server's Emergency Management Port (EMP). See the *SE7500WV2 or SE7501WV2 Technical Product Specifications* for more information concerning server management and EMP usage.

The intended use for the RJ45 serial port, located in the back of the system, is for remote EMP communication by connecting the port to a serial terminal concentrator. With the optional RJ45-to-DB9 adapter, the serial port can also be configured for use with a modem or other serial device requiring a DB9 connection to the serial port.

Serial terminal concentrators use one of two serial communication standards. Some terminal concentrators require a DC-to-DC (DCD) signal, while others require a DSR signal. The server boards SE7500WV2 and SE7501WV2 can be configured to support either of these configurations by setting the appropriate jumper on the jumper block, located directly behind the RJ45 serial connector on the baseboard. Refer to the *SE7500WV2 or the SE7501WV2 Technical Product Specifications* for additional configuration information of the serial port. If the RJ45-to-DB9 adapters are used – the proper adapter should be used with its corresponding jumper setting (DSR or DCD).

11. Regulatory and Integration Information

11.1 Product Regulatory Compliance

11.1.1 Product Safety Compliance

The SR2300 complies with the following safety requirements:

- UL 1950 - CSA 950 (US/Canada)
- EN 60 950 (European Union)
- IEC60 950 (International)
- CE – Low Voltage Directive (73/23/EEC) (European Union)
- EMKO-TSE (74-SEC) 207/94 (Nordics)

11.1.2 Product EMC Compliance

The SR2300 has been tested and verified to comply with the following electromagnetic compatibility (EMC) regulations when installed a compatible Intel host system. For information on compatible host system(s) refer to Intel's Server Builder website or contact your local Intel representative.

- FCC (Class A Verification) – Radiated & Conducted Emissions (USA)
- ICES-003 (Class A) – Radiated & Conducted Emissions (Canada)
- CISPR 22 (Class A) – Radiated & Conducted Emissions (International)
- EN55022 (Class A) – Radiated & Conducted Emissions (European Union)
- EN55024 (Immunity) (European Union)
- EN61000-3-2 & -3 (Power Harmonics & Fluctuation and Flicker)
- CE – EMC Directive (89/336/EEC) (European Union)
- VCCI (Class A) – Radiated & Conducted Emissions (Japan)
- AS/NZS 3548 (Class A) – Radiated & Conducted Emissions (Australia / New Zealand)
- RRL (Class A) Radiated & Conducted Emissions (Korea)
- BSMI (Class A) Radiated & Conducted Emissions (Taiwan)

11.1.3 Product Regulatory Compliance Markings

This product is provided with the following Product Certification Markings.

- UL / cUL Listing Mark
- CE Mark
- German GS Mark
- Russian GOST Mark
- FCC, Class A Verification Marking
- ICES-003 (Canada EMC Compliance Marking)
- VCCI, Class A Mark
- Australian C-Tick Mark
- Taiwan BSMI Certification Number and Class A Warning

11.2 Electromagnetic Compatibility Notices

11.2.1 USA

This device complies with Part 15 of the FCC Rules. Operation is subject to the following two conditions: (1) this device may not cause harmful interference, and (2) this device must accept any interference received, including interference that may cause undesired operation.

For questions related to the EMC performance of this product, contact:

Intel Corporation
5200 N.E. Elam Young Parkway
Hillsboro, OR 97124
1-800-628-8686

This equipment has been tested and found to comply with the limits for a Class A digital device, pursuant to Part 15 of the FCC Rules. These limits are designed to provide reasonable protection against harmful interference in a residential installation. This equipment generates, uses, and can radiate radio frequency energy and, if not installed and used in accordance with the instructions, may cause harmful interference to radio communications. However, there is no guarantee that interference will not occur in a particular installation. If this equipment does cause harmful interference to radio or television reception, which can be determined by turning the equipment off and on, the user is encouraged to try to correct the interference by one or more of the following measures:

- Reorient or relocate the receiving antenna.
- Increase the separation between the equipment and the receiver.
- Connect the equipment to an outlet on a circuit other than the one to which the receiver is connected.
- Consult the dealer or an experienced radio/TV technician for help.

Any changes or modifications not expressly approved by the grantee of this device could void the user's authority to operate the equipment. The customer is responsible for ensuring compliance of the modified product.

Only peripherals (computer input/output devices, terminals, printers, etc.) that comply with FCC Class B limits may be attached to this computer product. Operation with noncompliant peripherals is likely to result in interference to radio and TV reception.

All cables used to connect to peripherals must be shielded and grounded. Operation with cables, connected to peripherals, that are not shielded and grounded may result in interference to radio and TV reception.

11.2.2 FCC Verification Statement

Product Type: SR2300; SE7500WV2 and SE7501WV2

This device complies with Part 15 of the FCC Rules. Operation is subject to the following two conditions: (1) This device may not cause harmful interference, and (2) this device must accept any interference received, including interference that may cause undesired operation.

For questions related to the EMC performance of this product, contact:

Intel Corporation
5200 N.E. Elam Young Parkway
Hillsboro, OR 97124-6497
Phone: 1 (800)-INTEL4U or 1 (800) 628-8686

11.2.3 ICES-003 (Canada)

Cet appareil numérique respecte les limites bruits radioélectriques applicables aux appareils numériques de Classe A prescrites dans la norme sur le matériel brouilleur: "Appareils Numériques", NMB-003 édictée par le Ministre Canadien des Communications.

(English translation of the notice above) This digital apparatus does not exceed the Class A limits for radio noise emissions from digital apparatus set out in the interference-causing equipment standard entitled "Digital Apparatus," ICES-003 of the Canadian Department of Communications.

11.2.4 Europe (CE Declaration of Conformity)

This product has been tested in accordance too, and complies with the Low Voltage Directive (73/23/EEC) and EMC Directive (89/336/EEC). The product has been marked with the CE Mark to illustrate its compliance.

11.2.5 Japan EMC Compatibility

Electromagnetic Compatibility Notices (International)

この装置は、情報処理装置等電波障害自主規制協議会（VCCI）の基準に基づくクラス A 情報技術装置です。この装置を家庭環境で使用すると電波妨害を引き起こすことがあります。この場合には使用者が適切な対策を講ずるよう要求されることがあります。

English translation of the notice above:

This is a Class A product based on the standard of the Voluntary Control Council For Interference (VCCI) from Information Technology Equipment. If this is used near a radio or television receiver in a domestic environment, it may cause radio interference. Install and use the equipment according to the instruction manual.

11.2.6 BSMI (Taiwan)

The BSMI Certification number and the following warning is located on the product safety label which is located on the bottom side (pedestal orientation) or side (rack mount configuration).

警告使用者：

這是甲類的資訊產品，在居住的環境中使用時，可能會造成射頻干擾，在這種情況下，使用者會被要求採取某些適當的對策。

11.3 Replacing the Back up Battery

The lithium battery on the server board powers the real time clock (RTC) for up to 10 years in the absence of power. When the battery starts to weaken, it loses voltage, and the server settings stored in CMOS RAM in the RTC (for example, the date and time) may be wrong. Contact your customer service representative or dealer for a list of approved devices.



WARNING

Danger of explosion if battery is incorrectly replaced. Replace only with the same or equivalent type recommended by the equipment manufacturer. Discard used batteries according to manufacturer's instructions.



ADVARSEL!

Lithiumbatteri - Eksplosionsfare ved fejlagtig håndtering. Udskiftning må kun ske med batteri af samme fabrikat og type. Levér det brugte batteri tilbage til leverandøren.



ADVARSEL

Lithiumbatteri - Eksplosjonsfare. Ved utskifting benyttes kun batteri som anbefalt av apparatfabrikanten. Brukt batteri returneres apparatleverandøren.



WARNING

Explosionsfara vid felaktigt batteribyte. Använd samma batterityp eller en ekvivalent typ som rekommenderas av apparattillverkaren. Kassera använt batteri enligt fabrikantens instruktion.



VAROITUS

Paristo voi räjähtää, jos se on virheellisesti asennettu. Vaihda paristo ainoastaan laitevalmistajan suosittelemaan tyyppiin. Hävitä käytetty paristo valmistajan ohjeiden mukaisesti.

12. Environmental Limits

12.1 System Level Environmental Limits

The table below defines the system level operating and non-operating environmental limits (Office or Computer room Environment)

Table 30. System Office Environment Summary

Parameter	Limits
Operating Temperature	+10°C to +35°C with the maximum rate of change not to exceed 10°C per hour.
Non-Operating Temperature	-40°C to +70°C
Non-Operating Humidity	90%, non-condensing @ 35°C
Acoustic noise	Sound Pressure: 55 dBA (Rackmount) in an idle state at typical office ambient temperature. (23 +/- degrees C) Sound Power: 7.0 BA in an idle state at typical office ambient temperature. (23 +/- 2 degrees C)
Operating Shock	No errors with a half sine wave shock of 2G (with 11 millisecond duration).
Package Shock	Operational after a 24 inch free fall, although cosmetic damage may be present (Chassis Weight 40-80 lbs)
ESD	+/-15kV per Intel Environmental test specification
System Cooling Requirement in BTU/Hr	1826 BTU/hour

12.2 System Environmental Testing

The system will be tested per the Environmental Standards Handbook, Intel Doc.#662394-05. These tests includes:

- Temperature Operating and Non-Operating
- Humidity Non-Operating
- Packaged and Unpackaged Shock
- Packaged and Unpackaged Vibration
- AC Voltage, Freq. & Source Interrupt
- AC Surge
- Acoustics
- ESD
- EMC Radiated and Conducted Emissions Certifications

13. Serviceability and Availability

The system is designed to be serviced by qualified technical personnel only.

The desired Mean Time To Repair (MTTR) of the system is 30 minutes including diagnosis of the system problem. To meet this goal, the system enclosure and hardware have been designed to minimize the MTTR.

Following are the maximum times that a trained field service technician should take to perform the listed system maintenance procedures, after diagnosis of the system.

Table 31. Mean Time To Repair Estimate

Activity	Time Estimate
Remove cover	0.5 minutes
Remove and replace hard disk drive	3 minutes
Remove and replace power supply module	1 minute
Remove and replace power supply enclosure	10 minutes
Remove and replace front system fan	3 minutes
Remove and replace expansion board	5 minutes
Remove and replace front panel board	5 minutes
Remove and replace baseboard (with no expansion boards)	10 minutes

14. Calculated MTBF

The MTBF (Mean Time Between Failures) for the SR2300 Server chassis as configured from the factory is calculated at 35000 hours operating at 35 Degrees C.

Table 32. SR2300/SE7500WV2 Component MTBF

Sub Assembly	MTBF (Hours)	FIT (Failures/10 ⁹ hrs)
Server Board SE7500WV2	100,000	10,000
HDDI Board	1,500,000	667
PCI riser card	4,000,000	250
PCI riser card	4,000,000	250
Front Panel board	2,500,000	400

Table 33. SR2300/SE7501WV2 Component MTBF

Sub Assembly	MTBF (Hours)	FIT (Failures/10 ⁹ hrs)
Server Board SE7501WV2	TBD	TBD
HDDI Board	TBD	TBD
PCI riser card	TBD	TBD
PCI riser card	TBD	TBD
Front Panel board	TBD	TBD

This page intentionally left blank

Appendix A: SR2300 Integration and Usage Tips

This appendix provides a list of useful information that is unique to the SR2300 server chassis and should be kept in mind while integrating and configuring your SE7500WV2 or SE7501WV2-based servers.

- Only low-profile PCI add-in cards can be used in the PCI riser located closest to the edge of the chassis.
- The flex bay may be used to support a seventh LVD SCSI hard drive or a Floppy/CDROM or Floppy/DVD module.
- The optional Floppy/CDROM and Floppy/DVD modules are NOT hot-swappable. The system must be powered down before the module is inserted or removed.
- The SR2300 server chassis will not support single ended (SE) SCSI drives. Only LVD SCSI drives will be supported.
- Before installing the server boards SE7500WV2 or SE7501WV2 into the chassis, verify the sheet of mylar that sits between the server board and the sheet metal of the chassis is in place.
- When installing the server boards SE7500WV2 or SR7501WV2 into the chassis, verify that the back edge of the server board is sitting securely below the board retention stud protruding from the back wall of the chassis. This helps to keep the server board laying flat and prevents the board from flexing when removing the full length riser card.
- When installing the brown Floppy/FP/ATA cable, verify that both cable connectors are seated securely and lay flat to the connectors located on the baseboard and backplane.
- The blue system ID LEDs on both the server boards SE7500WV2 or SE7501WV2 and the SR2300 front panel are used to help locate a system for servicing when the server is installed in a rack with multiple servers installed. Both LEDs are illuminated when the ID button on the front panel is pushed, or in some cases may be illuminated remotely with a user defined server management interface.
- To remove the tape drive tray from the chassis, a spring latch located on the back right side of the carrier must be released allowing the drive tray to slide free. Do not attempt to pull the drive tray out without first releasing the spring latch, doing so may damage the plastic faceplate

Refer to the latest SR2300 Specification Update for a list of the latest specification changes, updates, and errata associated with the SR2300 server chassis. Specification updates are released on a monthly basis after production and can be downloaded from the Intel Customer Support Web site at <http://support.intel.com/>

Index

- 28F320C3, 55
- 2**
- Control panel, 2
 Critical condition, 33, 34
 Critical event logging error, 34
 Critical threshold crossing, 34
- 3-slot PCI riser cards, 52
- 3**
- 52271-2690, 48
 53C80S, 39
- 5**
- 8**
- 80C51, 38
 80C652, 38, 39
 82550PM, 55
- A**
- AC power input, 3
 agency certification, 58, 59
 AIC-7899W, 55
 Air flow, 16
 Air re-circulation, prevention, 20
 Airflow redundancy, 20
- B**
- battery
 disposing of safely, 60
 removing, 59
 BHS-33A-2.0D-SM, 46
 Bus temperature sensor, 41
- C**
- Cabinet mount kit, 7
 CD/FDD module signal interface connector, 48
 CD-ROM activity LED, 5
 CD-ROM drive eject button, 5
 CD-ROM signal interface connector, 47, 50
 certifications, 58, 59
 Chassis handles, 4
 Chassis intrusion, 34
 Chassis Intrusion Switch, 29
- D**
- DC output harness connectors, 17
 Degraded condition, 35
 Disk activity LED, 32
 Drive Act/Fault LED Indicators, 41
 Drive activity LED, 35
 Drive bay, 4, 47
 Drive power, 19, 36, 41
 Drive power-down, 40
 DS1624, 41
 Dual-mode SE/LVD, 36
- E**
- electromagnetic compatibility. *See* EMC
 EMC
 notice of test and compliance, international, 59
 EMI gasket, 3
 EMP, *See also* Emergency Management Port, 56
- F**
- Fan assembly, 7
 Fan cable/connector, 21
 Fan speed, 22
 FDD activity LED, 5
 FDD eject button, 5
 FDD signal interface connector, 51
 Flex bay, 2, 4, 6, 24, 25, 47, 1
 Floppy signal interface connector, 48
 Floppy/CDROM Module, 25
 Floppy/CD-ROM Module Connector, 44
 Floppy/DVD Module, 25
 Front bezel, 8, 32
 Front mount brackets, 7
 Front panel assembly, 28, 29, 30
 Front panel board, 2
 Front panel LEDs, 32
 Front Video, 30
 Front Video Port, 4
- H**
- Hard disk drive status LED, 5
 Hard drive bay, 2
 Hard drive bays, 6, 24
 HDD activity/fault indicator, 4

Hot-spare drive support, 40
Hot-swap drive bay, 36, 40

I

I/O shield, 3
I²C, 43
I²C electrical input/output specifications, 38
ID button, 29, 35, 1
ID Button, 5
ID LED, 5, 29, 35
Internal Management Bus, 41
Intrusion switch, 2, 7, 29
IPMB, See also Intelligent Platform Management Bus,
43

K

Key-locked front bezel, 7
Kx14-50K5D1, 50, 51

L

LED, 43
lithium backup battery
 disposing of safely, 60
 removing, 59

M

Manual CD-ROM drive eject button (Tool assisted), 5
Mean Time Between Failures, 63
Mean Time To Repair, 62
MTBF, 63
MTTR, 62
Multi-mode terminators, 39

N

NIC1 / NIC2 activity LED, 32
NIC1 activity LED, 5
NIC2 activity LED, 5
NMI, 43
NMI button, 5, 29
Noise margin, 39
Non-critical condition, 34

P

P1.6, 38
P1.7, 38
P80C652FBB, 37, 38
PCI add-in card, 2, 52

PCI buses, 55
PCI card bracket, 2, 3
PDC20267, 55
Power / sleep LED, 32
Power button, 5, 29
Power management signals, 19
Power subsystem failure, 34
Power supply, 2
Power supply, 18
Power supply bay, 6
Power supply cage, 9, 11, 13, 17
Power supply LED, 13
Power supply module, 3, 6, 11, 12, 13, 62
Power supply module handle, 11
Power/sleep LED, 5
Power/Sleep LED, 5
PS/2 mouse/keyboard connector, 3

R

Relay rack, 7
Reset button, 29
Reset Button, 5
Reset types, 37
Riser card assembly, 2
RJ45 NIC 1 connector, 3
RJ45 NIC 2 connector, 3
RJ45 Serial B port, 3

S

SCB2, 18, 56
SCSI connector, 3
SCSI connectors, 36
SCSI drives, hot-swap, 25
SCSI interface, 39
SCSI termination, 36
SE7500WV2, 56
Serial, 56
Serial A port mounting hole, 3
Set Fault Indication command, 34
Sliding rail kit, 7
South Bridge, 55
SYM53C80S, 39
System controls, 4
System fans, 2
System identification LED, 32, 35
System state LED, 32

T

Tape drive bay, 2, 4, 24
Thermal protection, 19

U

UCC5638, 40
USB connector, 3
USB connector 3, 4

W

Warning
dispose of lithium battery safely, 60
WR-100S-VF-1, 43

V

VCCI notice, 59
Video connector, 3