



Intel® Entry Server Chassis SC5295-E

Technical Product Specification

D18216-001

Revision 1.0

August, 2005

Enterprise Platforms and Services Marketing

Revision History

Date	Revision Number	Modifications
Aug. 19, 2005	1.0	Initial Release

Disclaimers

Information in this document is provided in connection with Intel® products. No license, express or implied, by estoppel or otherwise, to any intellectual property rights is granted by this document. Except as provided in Intel's Terms and Conditions of Sale for such products, Intel assumes no liability whatsoever, and Intel disclaims any express or implied warranty, relating to sale and/or use of Intel products including liability or warranties relating to fitness for a particular purpose, merchantability, or infringement of any patent, copyright or other intellectual property right. Intel products are not intended for use in medical, life saving, or life sustaining applications. Intel may make changes to specifications and product descriptions at any time, without notice.

Designers must not rely on the absence or characteristics of any features or instructions marked "reserved" or "undefined." Intel reserves these for future definition and shall have no responsibility whatsoever for conflicts or incompatibilities arising from future changes to them.

This document contains information on products in the design phase of development. Do not finalize a design with this information. Revised information will be published when the product is available. Verify with your local sales office that you have the latest datasheet before finalizing a design.

The Intel® Entry Server Chassis SC5295-E may contain design defects or errors known as errata which may cause the product to deviate from published specifications. Current characterized errata are available on request.

Intel Corporation server baseboards contain a number of high-density VLSI and power delivery components that need adequate airflow to cool. Intel's own chassis are designed and tested to meet the intended thermal requirements of these components when the fully integrated system is used together. It is the responsibility of the system integrator that chooses not to use Intel developed server building blocks to consult vendor datasheets and operating parameters to determine the amount of air flow required for their specific application and environmental conditions. Intel Corporation can not be held responsible if components fail or the server board does not operate correctly when used outside any of their published operating or non-operating limits.

Intel, Pentium, Itanium, and Xeon are trademarks or registered trademarks of Intel Corporation.

*Other brands and names may be claimed as the property of others.

Copyright © Intel Corporation 2005.

Table of Contents

1. Product Overview	1
1.1 Intel® Entry Server Chassis SC5295-E Design Features.....	1
1.2 Chassis Views	4
1.3 System Color	8
1.4 Chassis Security	8
1.5 I/O Panel.....	8
1.6 Rack and Cabinet Mounting Option.....	8
1.7 Front Bezel Features	9
1.8 Peripheral Bays	9
2. Power Sub-system	10
2.1 350-Watt Power Supply	10
2.1.1 Mechanical Overview	10
2.1.2 Airflow and Temperature.....	12
2.1.3 Output Cable Harness.....	12
2.1.4 AC Input Requirements.....	15
2.1.5 DC Output Specifications	17
2.1.6 Protection Circuits	22
2.2 420-Watt Power Supply	24
2.2.1 Mechanical Overview	25
2.2.2 Airflow and Temperature.....	26
2.2.3 Output Cable Harness.....	26
2.2.4 AC Input Requirements.....	30
2.2.5 DC Output Specifications	33
2.2.6 Protection Circuits	38
2.3 500-Watt Power Supply	41
2.3.1 Mechanical Overview	41
2.3.2 Handle and Retention Mechanism	42
2.3.3 Hot Swap Support.....	42
2.3.4 Airflow and Temperature.....	42
2.3.5 Output Cable Harness.....	43
2.3.6 AC Input Requirements.....	43
2.3.7 DC Output Specification.....	46

2.3.8	Protection Circuits	50
2.3.9	SMBus Monitoring Interface	54
2.4	500-Watt Power Distribution Board	54
2.4.1	Mechanical Overview	55
2.4.2	Airflow and Temperature Requirements	55
2.4.3	Electrical Specification	56
2.4.4	Efficiency	62
2.4.5	Grounding	62
2.4.6	Remote Sense	63
2.4.7	Outputs Load Requirements	63
2.4.8	DC/DC Converters Voltage Regulation	63
2.4.9	DC / DC Converters Dynamic Loading	64
2.4.10	DC / DC Converter Capacitive Loading	65
2.4.11	DC/DC Converters Ripple / Noise	65
2.4.12	Protection Circuits	65
2.4.13	Control and Indicator Functions (Hard-wired)	66
2.4.14	SMBUS Monitoring Interface	68
2.5	600-Watt Power Supply	68
2.5.1	Mechanical Overview	69
2.5.2	Airflow and Temperature	70
2.5.3	Output Cable Harness	70
2.5.4	AC Input Requirements	77
2.5.5	DC Output Specifications	79
2.5.6	Protection Circuits	85
2.5.7	Control and Indicator Functions	87
3.	Chassis Cooling	89
3.1	Fan Configuration	89
3.1.1	Intel® Entry Server Chassis SC5295-E UP/DP/BRP Fan Configuration	89
3.1.2	Intel® Entry Server Chassis SC5295-E WS Fan Configuration	89
3.2	Server Board Fan Control	90
3.3	Cooling Solution	90
4.	Peripheral and Hard Drive Support	92
4.1	3.5-in Peripheral Drive Bay	92
4.2	5.25-in Peripheral Drive Bays	93
4.3	Hard Disk Drive Bays	93

4.3.1	Fixed Hard Drive Bay	93
4.3.2	6HDD SCSI Hot-Swap Backplane (HSBP) Overview	94
4.3.3	Serial-ATA (SATA) Hot Swap Back Plane (HSBP)	104
5.	Standard Control Panel	116
5.1	SC5295UP Control Panel	116
5.2	SC5295DP/WS/BRP Control Panel	117
6.	Intel® Local Control Panel.....	119
6.1	Internal Control Panel Headers	120
7.	System Interconnection.....	121
7.1	Signal Definitions	121
7.2	Chassis Internal Cables.....	121
7.2.1	Control Panel Cable	121
7.2.2	USB Cable	121
7.2.3	Fan Connector	121
7.2.4	Chassis Intrusion Cable	121
7.3	Server Board Internal Cables	121
7.4	Accessory Cables	122
7.4.1	External SCSI Cable	122
7.5	I/O Panel Connectors	122
7.6	Spares and Accessories	122
8.	Supported Intel® Server Boards	123
9.	Regulatory, Environmentals, and Specifications	124
9.1	Product Regulatory Compliance	124
9.1.1	Product Safety Compliance.....	124
9.1.2	Product EMC Compliance – Class A Compliance	124
9.1.3	Certifications / Registrations / Declarations	125
9.1.4	Product Regulatory Compliance Markings.....	126
9.2	Electromagnetic Compatibility Notices	127
9.2.1	FCC Verification Statement (USA).....	127
9.2.2	ICES-003 (Canada).....	128
9.2.3	Europe (CE Declaration of Conformity).....	128
9.2.4	Japan EMC Compatibility	128
9.2.5	BSMI (Taiwan)	128
9.2.6	RRL (Korea).....	129
9.2.7	CNCA (CCC-China)	129

9.3 Regulated Specified Components..... 129

9.4 Replacing the Back up Battery 129

9.5 System Level Environmental Limits 130

9.6 Serviceability and Availability..... 131

9.7 Calculated MTBF 131

Appendix A: Integration and Usage Tips..... 133

Glossary..... 134

List of Figures

Figure 1. Front Closed Chassis View of Intel® Entry Server Chassis SC5295-E DP/WS/BRP...	4
Figure 2. Front Closed Bezel View of Intel® Entry Server Chassis SC5295-E UP.....	5
Figure 3. Rear Closed Chassis View of Intel® Entry Server Chassis SC5295-E UP/DP/WS/BRP6	
Figure 4. Front Internal Chassis View of Intel® Entry Server Chassis SC5295-E DP/WS/BRP ..	7
Figure 5. Rear Internal Chassis View of Intel® Entry Server Chassis SC5295-E UP/DP/WS/BRP	7
Figure 6. ATX 2.2 I/O Aperture	8
Figure 7. Mechanical Drawing for Power Supply Enclosure and Output Cable Harness	11
Figure 8. Output Voltage Timing	21
Figure 9. Mechanical Drawing for Power Supply Enclosure	25
Figure 10. Output Cable Harness for 420-W Power Supply	27
Figure 11. Output Voltage Timing	37
Figure 12. Mechanical Drawing for Dual (1+1 configuration) Power Supply Enclosure with Power Distribution Board.....	41
Figure 13. Output Voltage Timing	49
Figure 14. Mechanical Drawing for Dual (1+1 configuration) Power Supply Enclosure with Power Distribution Board.....	55
Figure 15. Output Cable Harness for 500-W Power Supply	58
Figure 16. Mechanical Drawing for the Power Supply Enclosure	69
Figure 17. Output Cable Harness for 600-W Power Supply	71
Figure 18. Output Voltage Timing	84
Figure 19. Cooling Fan Configuration	90
Figure 20. Drive Bay Locations for Intel® Entry Server Chassis SC5295-E.....	92
Figure 21. 6-HDD Fixed Drive Bay, Rear Isometric View	94
Figure 22. 68-Pin SCSI Cable Connector	96
Figure 23. 68-Pin SCSI Cable Connector	99
Figure 24. 6 HDD Hot Swap Drive Bay, Rear / Front Isometric View	103
Figure 25. Drive Carrier with Air Baffle Installed	103
Figure 26. Hard Drive Carrier Assembly	104
Figure 27. Intel® Entry Server Chassis SC5295-E 6HDD SATA HSBP Block Diagram.....	105
Figure 28. Intel® Entry Server Chassis SC5295-E 6HDD SATA HSBP I ² C Bus Connection Diagram.....	107

Figure 29. Intel® Entry Server Chassis SC5295-E 6HDD SATA Hot Swap Backplane Board Layout..... 114

Figure 30. Panel Controls and Indicators for UP Configuration 116

Figure 31. Panel Controls and Indicators for DP, WS, and BRP Configurations 117

Figure 32. SKU3: Pedestal Server Application 119

Figure 33. Local Control Panel Components 119

List of Tables

Table 1. Intel® Entry Server Chassis SC5295-E UP, DP, BRP, and WS Features.....	2
Table 2. Environmental Requirements.....	12
Table 3. Cable Lengths.....	12
Table 4. P1 Baseboard Power Connector	13
Table 5. P2 Processor Power Connector.....	14
Table 6. P3-P6, P8-P9 Peripheral Connectors	14
Table 7. P5 Floppy Power Connector	14
Table 8. P11 SATA Power Connector	15
Table 9. AC Input Rating.....	15
Table 10. AC Line Sag Transient Performance	16
Table 11. AC Line Surge Transient Performance.....	17
Table 12. Load Ratings.....	18
Table 13. Voltage Regulation Limits	18
Table 14. Transient Load Requirements.....	19
Table 15. Capacitive Loading Conditions	19
Table 16. Ripple and Noise.....	20
Table 17. Output Voltage Timing	20
Table 18. Turn On / Off Timing	21
Table 19. Over Voltage Protection Limits	23
Table 20. PSON [#] Signal Characteristic.....	23
Table 21. PWOK Signal Characteristics	24
Table 22. Environmental Requirements.....	26
Table 23. Cable Lengths.....	28
Table 24. P1 Baseboard Power Connector	28
Table 25. P2 Processor Power Connector.....	29
Table 26. P3-P6, P8-P9 Peripheral Connectors	29
Table 27. P10 Right-angle SATA Power Connector.....	30
Table 28. AC Input Rating.....	30
Table 29. AC Line Sag Transient Performance	32
Table 30. AC Line Surge Transient Performance.....	32
Table 31. Load Ratings.....	33
Table 32. Voltage Regulation Limits	34

Table 33. Transient Load Requirements.....	34
Table 34. Capacitive Loading Conditions	35
Table 35. Ripple and Noise.....	35
Table 36. Output Voltage Timing	36
Table 37. Turn On / Off Timing	37
Table 38. Over Voltage Protection Limits	39
Table 39. PSON# Signal Characteristic.....	40
Table 40. PWOK Signal Characteristics	40
Table 41. Environmental Requirements.....	42
Table 42. AC Input Rating.....	43
Table 43. Efficiency.....	43
Table 44. Holdup Requirements	44
Table 45. AC Line Sag Transient Performance	45
Table 46. AC Line Surge Transient Performance	45
Table 47. Power Supply Edge Connector Slot Pin-out (location)	46
Table 48. Power Supply Module Load Ratings.....	47
Table 49. Voltage Regulation Limits	47
Table 50. Transient Load Requirements.....	48
Table 51. Capacitive Loading Conditions	48
Table 52. Ripple and Noise.....	48
Table 53. Output Voltage Timing	49
Table 54. Turn On / Off Timing	50
Table 55. Over Current Protection (OCP).....	51
Table 56. Over Voltage Protection Limits	51
Table 57. PSON# Signal Characteristic.....	52
Table 58. PSKILL Signal Characteristics	52
Table 59. PWOK Signal Characteristics	53
Table 60. LED Indicators	54
Table 61. Environmental Requirements.....	56
Table 62. Edge Finger Power Supply Connector Pin-out	56
Table 63. Cable Lengths.....	59
Table 64. P1 Baseboard Power Connector	59
Table 65. P2 Processor Power Connector.....	60
Table 66. Power Signal Connector	61
Table 67. Peripheral Power Connectors	61

Table 68. Floppy Power Connector	61
Table 69. SATA Power Connector	62
Table 70. SATA Power Connector	62
Table 71. Cage Load Ratings	63
Table 72. Voltage Regulation Limits	64
Table 73. Transient Load Requirements	64
Table 74. Capacitive Loading Conditions	65
Table 75. Ripple and Noise.....	65
Table 76. Over Current Protection Limits / 240VA Protection.....	66
Table 77. Over Voltage Protection (OVP) Limits	66
Table 78. PSON# Signal Characteristics.....	67
Table 79. PWOK Signal Characteristics	68
Table 80. Environmental Requirements.....	70
Table 81. Cable Lengths.....	72
Table 82. P1 Baseboard Power Connector	73
Table 83. P2 Processor Power Connector.....	74
Table 84. Power Signal Connector	74
Table 85. PCI Express Connector	75
Table 86. Peripheral Connectors	75
Table 87. P7 Right-angle Peripheral Power Connector	75
Table 88. P5 Floppy Power Connector	76
Table 89. P12 Right-angle SATA Power Connector	76
Table 90. P13 SATA Power Connector	76
Table 91. AC Input Rating.....	77
Table 92. AC Line Sag Transient Performance	78
Table 93. AC Line Surge Transient Performance	79
Table 94. Load Ratings.....	80
Table 95. Voltage Regulation Limits	81
Table 96. Transient Load Requirements.....	82
Table 97. Capacitive Loading Conditions	82
Table 98. Ripple and Noise.....	83
Table 99. Output Voltage Timing	83
Table 100. Turn On / Off Timing	84
Table 101. Over Current Protection (OCP).....	85
Table 102. Over Voltage Protection Limits	86

Table 103. PSON# Signal Characteristic.....	87
Table 104. PWOK Signal Characteristics	88
Table 105. Power Connector Pin-out.....	96
Table 106. SCA2 SCSI Connector Pin-out	97
Table 107. 68-pin SCSI Connector Pin-out.....	99
Table 108. IPMB Header Pin-out	101
Table 109. Hot Swap Backplane Worst-case Power Budget.....	101
Table 110. Hard Drive Activity LED	102
Table 111. SCSI Backplane LED.....	102
Table 112. I ² C Bus Addressing.....	107
Table 113. I ² C Bus Loading	107
Table 114. GEM424* Controller GPIO Assignment	109
Table 115. LED Function	110
Table 116. 7-pin SATA Connector Pin-out.....	111
Table 117. 22-pin SATA Connector Pin-out.....	111
Table 118. Power Connector Pin-out.....	112
Table 119. IPMB Header Pin-out	113
Table 120. SATA Host I ² C Header Pin-out	113
Table 121. SATA Hot Swap Backplane Connector Specifications	114
Table 122. UP Control Panel LED Functions.....	117
Table 123. Control Panel LED Functions.....	118
Table 124. IPMI Header.....	120
Table 125. System Office Environment Summary	130
Table 126. Mean Time To Repair Estimate	131
Table 127. Intel® Entry Server Chassis SC5295-E Component MTBF	132

1. Product Overview

The Intel® Entry Server Chassis SC5295-E is a 5.2U pedestal or 6U rack mountable server chassis that is designed to support Intel® Server Boards SE7320EP2, SE7525RP2, SE7520BD2 and SE7230NH1-E. This chapter provides a high-level overview of the chassis features. Greater detail for each major chassis component or feature is provided in the following chapters.

1.1 Intel® Entry Server Chassis SC5295-E Design Features

The Intel® Entry Server Chassis SC5295-E addresses the value server market with four power factor correction (PFC) power supply unit (PSU) configurations:

- SC5295UP – 350-W fixed PSU for uni-processor server boards
- SC5295DP – 420-W fixed PSU for dual-processor server boards
- SC5295WS – 600-W fixed PSU for dual-processor workstation boards
- SC5295BRP – 500-W 1+1 redundant PSU for dual-processor server boards

The UP, DP, and WS power supply configurations each include an Intel validated PSU with an integrated cooling fan and one AC line input. The BRP power supply configuration includes (1 of 2) redundant Intel validated PSU with an integrated cooling fan and one AC line input.

The cooling sub-system in the Intel® Entry Server Chassis SC5295-E consists of one 120-mm system fan and one power supply fan. A 92-mm fan is included with the optional hot swap drive bay. A 50-mm memory fan is also required for some Intel® server boards and comes standard with the SC5295WS configuration.

A removable access cover provides entry to the interior of the chassis. The rear I/O panel conforms to the *Advanced Technology Extended (ATX) Specification*, Revision 2.2. The chassis supports six full-length expansion cards. There are two front USB port connections, and one rear knock-out location for an optional rear mounted serial port. A control panel board designed for Server Standards Infrastructure (SSI) Entry E-Bay (EEB) 3.5-compliant server boards is also provided with the server chassis.

The Intel® Entry Server Chassis SC5295-E supports up to four hard drives in the SC5295UP and SC5295DP configurations, and up to six hard drives in the SC5295BRP and SC5295WS configurations. Two 5.25-in, half-height drive bays are available for peripherals, such as CD/DVD-ROM drives and tape drives. Optional hot-swap SCSI and SATA drive bay kits provide an upgrade path to allow the Intel® Entry Server Chassis SC5295-E to support up to six hot-swap drives. The optional hot-swap SCSI hard disk drive bay supports up to six 1-in single connector attachment (SCA) low-voltage differential (LVD) SCSI hard drives to enhance serviceability, availability, and upgradeability of the system. Refer to the *Drive Cage Upgrade Kit Installation Guide* for the Intel® Entry Server Chassis SC5295-E for complete hot swap drive cage installation instructions. When installed, the hot-swap drive bay replaces the fixed hard drive bay.

The Intel® Entry Server Chassis SC5295-E makes extensive use of tool-less hardware features that support tool-less installation and removal of fans, fixed and hot swap hard drives, fixed and hot swap drive bays, PCI cards, hot swap PSU modules, floppy drives, and CD/DVD ROM drives.

This specification details the key features of the product. Reference documents listed at the back of this document provide additional product specification details for the server boards, backplanes, and power supplies validated for use with this chassis. Check the compatibility section on the support website for more details:

<http://support.intel.com/support/motherboards/server/chassis/SC5295-E/>.

The following table summarizes the features for all chassis combinations.

Table 1. Intel® Entry Server Chassis SC5295-E UP, DP, BRP, and WS Features

Configuration	SC5295UP	SC5295DP	SC5295BRP	SC5295WS
Intel® Server Board Support	SE7230NH1-E	SE7520BD2 SE7320EP2	SE7520BD2 SE7320EP2	SE7525RP2
Power Delivery	350-W PFC Intel validated PSU with integrated cooling fan.	420-W PFC Intel validated PSU with integrated cooling fan.	500-W PFC Intel validated PSU with integrated cooling fan. One additional 500-W PSU can be added for redundancy.	600-W PFC Intel validated PSU with integrated cooling fan.
System Cooling	One tool-less, 120-mm chassis fan.	One tool-less, 120-mm chassis fan.	One tool-less, 120-mm chassis fan.	One tool-less, 120-mm chassis fan, and one 50-mm memory cooling fan.
Peripheral Bays	Two tool-less, multi-mount 5.2-in peripheral bays. One standard floppy bay.	Two tool-less, multi-mount 5.25-in peripheral bays. One standard floppy bay.	Two tool-less, multi-mount 5.25-in peripheral bays. One standard floppy bay.	Two tool-less, multi-mount 5.25-in peripheral bays. One standard floppy bay.
Drive Bays	Includes one tool-less fixed drive bay. Supports up to four fixed drives.	Includes one tool-less fixed drive bay. Supports up to four hard drives. Optional hot-swap tool-less drive bay is available.	Includes one tool-less fixed drive bay for up to six fixed drives. Optional hot-swap tool-less six-drive bay is available.	Includes one tool-less fixed drive bay for up to six fixed drives. Optional hot-swap tool-less six-drive bay is available.
PCI Slots	7 slots and support for 5 full length with tail card guide	7 slots and support for 5 full length with tail card guide	7 slots and support for 5 full length with tail card guide	7 slots and support for 5 full length with tail card guide
Form Factor	5.2U tower, convertible to 6U rack mount	5.2U tower, convertible to 6U rack mount	5.2U tower, convertible to 6U rack mount	5.2U tower, convertible to 6U rack mount

Front Panel	LED power status. Switch for power. Integrated temperature sensor for fan speed management.	LEDs for NIC1, NIC2, HDD activity/failure, power status, and system fault status. Switches for power and reset. Integrated temperature sensor for fan speed management.	LEDs for NIC1, NIC2, HDD activity/failure, power status, and system fault status. Switches for power and reset. Integrated temperature sensor for fan speed management.	LEDs for NIC1, NIC2, HDD activity/failure, power status, and system fault status. Switches for power and reset. Integrated temperature sensor for fan speed management.
External front connectors	Two USB ports	Two USB ports	Two USB ports	Two USB ports
Color	Black	Black	Black	Black
Construction	1.0-mm, zinc-plated sheet metal, meets Intel Cosmetic Spec # C25432	1.0-mm, zinc-plated sheet metal, meets Intel Cosmetic Spec # C25432	1.0-mm, zinc-plated sheet metal, meets Intel Cosmetic Spec # C25432	1.0-mm, zinc-plated sheet metal, meets Intel Cosmetic Spec # C25432
Chassis ABS	Fire retardant, non-brominated PC-ABS	Fire retardant, non-brominated PC-ABS	Fire retardant, non-brominated PC-ABS	Fire retardant, non-brominated PC-ABS
Dimensions Pedestal	17.8 in (45.2 cm) x 9.256 in (23.5 cm) x 19 in (48.3 cm)	17.8 in (45.2 cm) x 9.256 in (23.5 cm) x 19 in (48.3 cm)	17.8 in (45.2 cm) x 9.256 in (23.5 cm) x 19 in (48.3 cm)	17.8 in (45.2 cm) x 9.256 in (23.5 cm) x 19 in (48.3 cm)
Dimensions Rack	9.256 in (23.5 cm) x 17.6 in (44.7 cm) x 19 in (48.3 cm)	9.256 in (23.5 cm) x 17.6 in (44.7 cm) x 19 in (48.3 cm)	9.256 in (23.5 cm) x 17.6 in (44.7 cm) x 19 in (48.3 cm)	9.256 in (23.5 cm) x 17.6 in (44.7 cm) x 19 in (48.3 cm)

1.2 Chassis Views

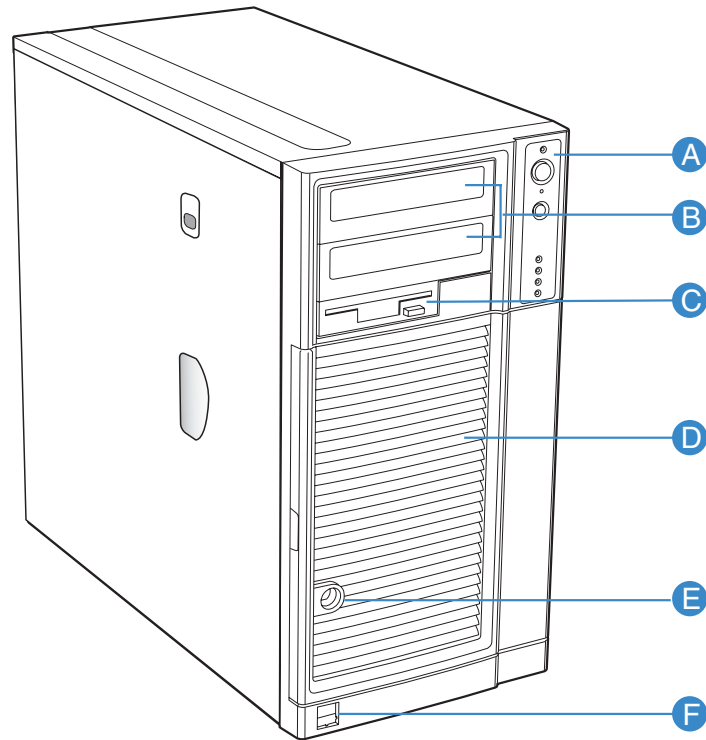

TP01717

- A. Control panel controls and indicators
- B. Two half height 5.25-in peripheral drive bays
- C. 3.5-in removable media drive bay
- D. Internal hard drive bay cage (behind door)
- E. Security lock
- F. USB ports

Figure 1. Front Closed Chassis View of Intel® Entry Server Chassis SC5295-E DP/WS/BRP

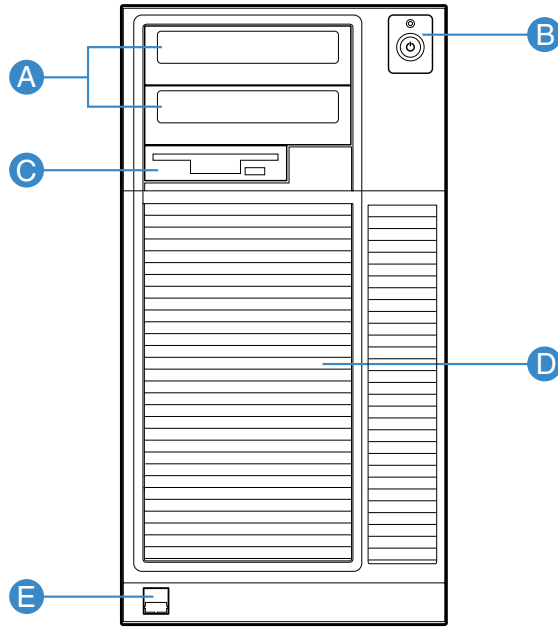

TP00833

- A. Two half-height 5.25-in peripheral drive bays
- B. Control panel controls and indicators
- C. 3.5-in removable media drive bay
- D. Internal hard drive bay cage (behind bezel)
- E. USB ports

Figure 2. Front Closed Bezel View of Intel® Entry Server Chassis SC5295-E UP

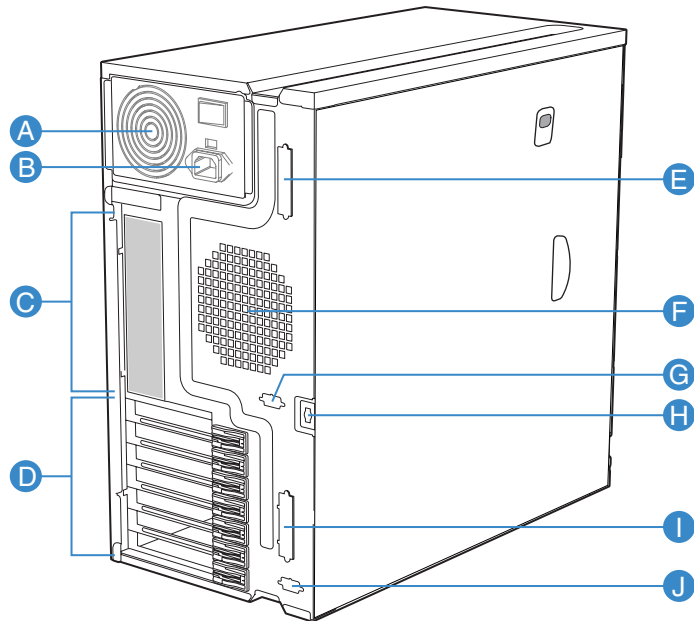

TP00866

- A. Power supply (fixed power supply shown)
- B. AC input power connector
- C. I/O Ports
- D. Expansion slot covers
- E. Alternate external SCSI knockout
- F. 120-mm system fan
- G. Serial B port knockout
- H. Location to install padlock loop
- I. External SCSI knockout
- J. Alternate Serial B port knockout

Figure 3. Rear Closed Chassis View of Intel® Entry Server Chassis SC5295-E UP/DP/WS/BRP

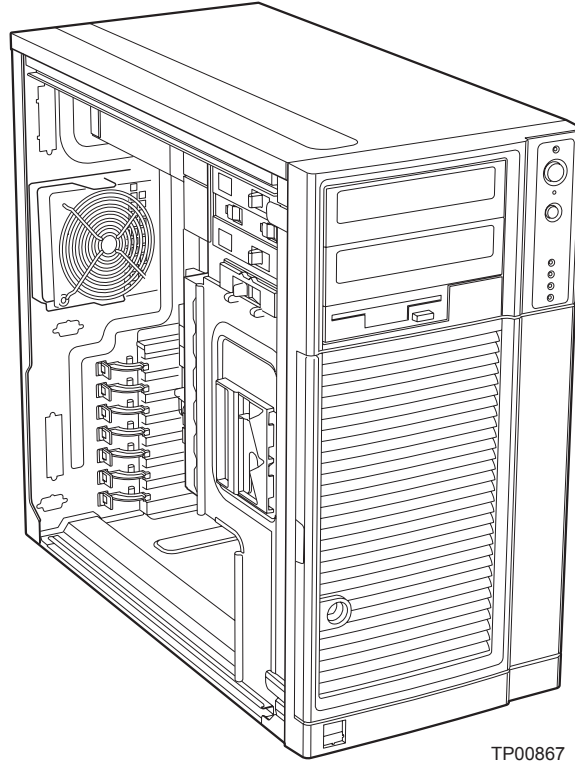

TP00867

Figure 4. Front Internal Chassis View of Intel® Entry Server Chassis SC5295-E DP/WS/BRP

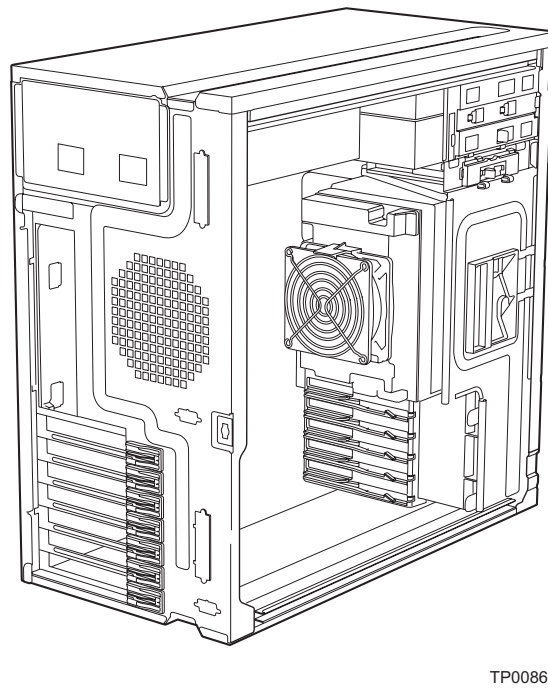

TP00868

Figure 5. Rear Internal Chassis View of Intel® Entry Server Chassis SC5295-E UP/DP/WS/BRP

1.3 System Color

The Intel® Entry Server Chassis SC5295-E is offered in one color:

- Black (GE701)

1.4 Chassis Security

A variety of chassis security options are provided at the system level:

A removable padlock loop at the rear of the system access cover can be used to prevent access to the microprocessors, memory, and add-in cards. A variety of lock sizes can be accommodated by the 0.270-inch diameter loop.

- A two-position key lock/switch will unlock the front bezel for DP, WS, and BRP configurations. The SC5295UP chassis configuration has no door and no lock.
- A chassis intrusion switch is provided, allowing server management software to detect unauthorized access to the system side cover.

Note: See the technical product specification appropriate to the server board for a description of BIOS and management security features for each specific supported platform. The technical product specifications can be found at <http://support.intel.com>.

1.5 I/O Panel

All input/output (I/O) connectors are accessible from the rear of the chassis. The SSI E-bay 3.5-compliant chassis provides an ATX 2.2-compatible cutout for I/O shield installation. Boxed Intel® server boards provide the required I/O shield for installation in the cutout. The I/O cutout dimensions are shown in the following figure for reference.

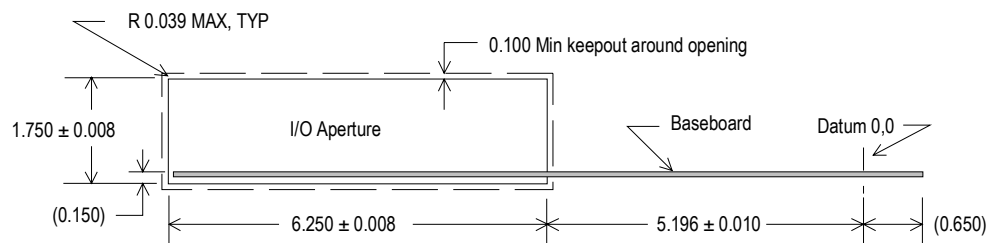

Figure 6. ATX 2.2 I/O Aperture

1.6 Rack and Cabinet Mounting Option

The Intel® Entry Server Chassis SC5295-E supports a rack mount configuration. The rack mount kit includes the chassis slide rails, rack handle, rack orientation label, screws, and manual. This rack mount kit is designed to meet the EIA-310-D enclosure specification. General rack compatibility is further described in the "Server Rack Cabinet Compatibility Guide" found at <http://support.intel.com>.

1.7 Front Bezel Features

Two front bezel types are used for the Intel® Entry Server Chassis SC5295-E: one for the UP configuration and one for the DP/WS/BRP configurations. Both are constructed of molded plastic and attach to the front of the chassis with three clips on the right side and two snaps on the left. The snaps at the left attach behind the access cover, thereby preventing accidental removal of the bezel. The bezel can only be removed by first removing the server access cover. This provides additional security to the hard drive and peripheral bay area. The DP/WS/BRP bezel also includes a key-locking door that covers the drive cage area and allows access to hot swap drives when a hot swap drive bay is installed. The UP bezel does not have a door.

The peripheral bays are covered with plastic snap-in cosmetic pieces that must be removed to add peripherals to the system. Control panel buttons and lights are located along the right side of the peripheral bays.

1.8 Peripheral Bays

Two 5.25-in, half-height drive bays are available for CD/DVD-ROM or tape drives as well as one 3.5-inch bay for a floppy drive. Drive installation is tool-less and requires no screws.

2. Power Sub-system

2.1 350-Watt Power Supply

The 350-W power supply (PS) specification defines a non-redundant power supply that supports UP entry server systems. The parameters of this power supply are defined in this specification for open industry use. This specification defines a 350-W power supply with 6 outputs; 3.3V, 5V, 12V1, 12V2, -12V and 5Vsb. The AC Input is 115V/230V selectable and power factor corrected for 230V only. The power supply contains one 80-mm ball bearing fan for cooling the power supply and part of the system. The form factor is ATX12V.

2.1.1 Mechanical Overview

The physical size of the power supply enclosure is intended to accommodate power requirements up to 350 W. The power supply size is 86X150X140mm and has a wire harness for the DC outputs. The AC plugs directly into the external face of the power supply.

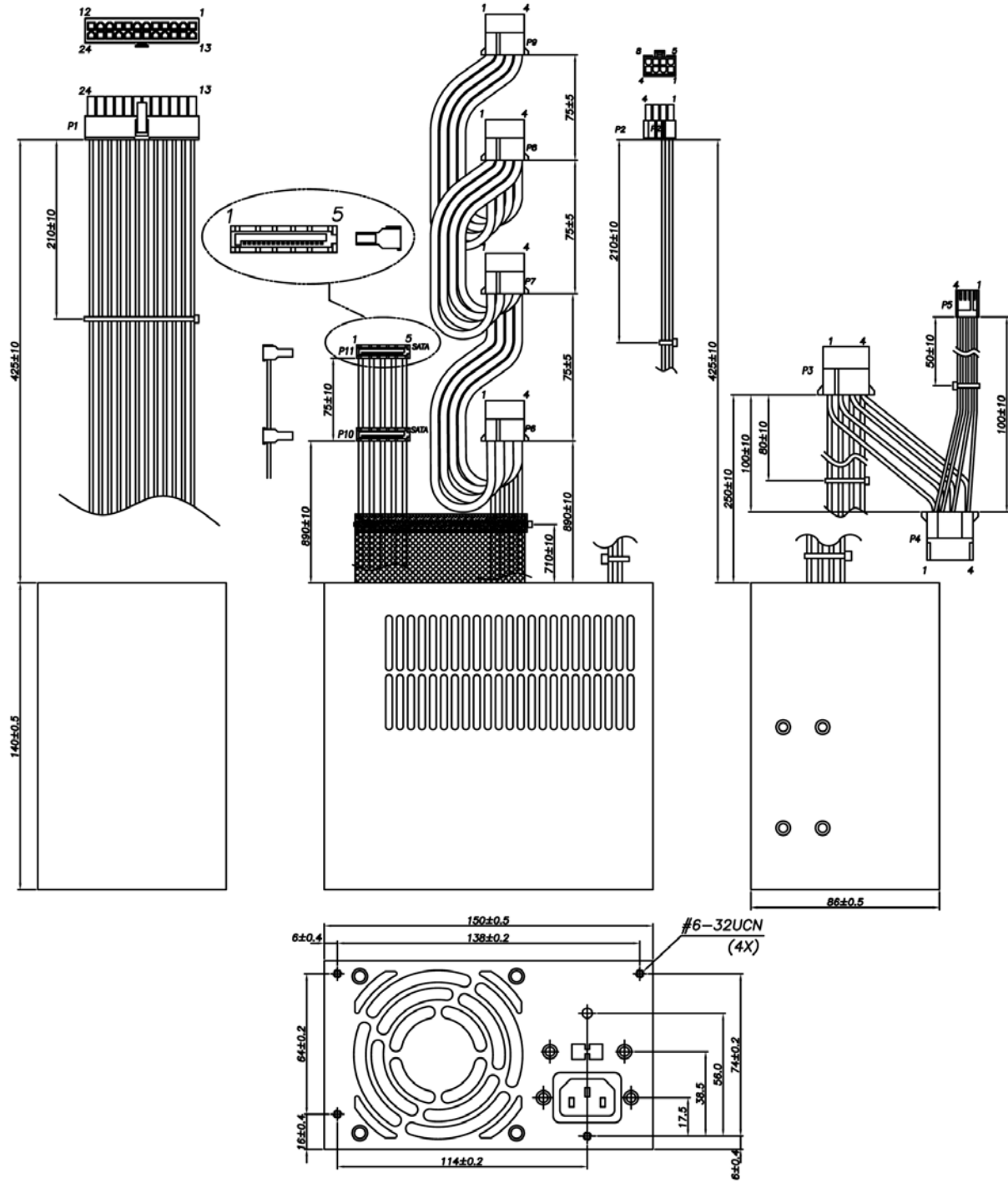

Figure 7. Mechanical Drawing for Power Supply Enclosure and Output Cable Harness

2.1.2 Airflow and Temperature

The power supply operates within all specified limits over the T_{op} temperature range. The average air temperature difference (ΔT_{ps}) from the inlet to the outlet of the power supply does not exceed 20 degrees C. All airflow passes through the power supply and not over the exterior surfaces of the power supply.

Table 2. Environmental Requirements

Item	Description	Min	Specification	Units
T_{op}	Operating temperature range	0	50	°C
T_{non-op}	Non-operating temperature range	-40	70	°C
Altitude	Maximum operating altitude		1500	m

The power supply meets UL enclosure requirements for temperature rise limits. All sides of the power supply, with exception of the air exhaust side, are classified as “Handle, knobs, grips, etc. held for short periods of time only.”

2.1.3 Output Cable Harness

Listed or recognized component appliance wiring material (AVLV2), CN, rated min 80°C, 300Vdc is used for all output wiring.

Table 3. Cable Lengths

From	To Connector #	Length (mm)	No of Pins	Description
Power Supply cover exit hole	P1	425	24	Baseboard Power Connector
Power Supply cover exit hole	P2	425	8	Processor Power Connector
Power Supply cover exit hole	P3	250	4	Peripheral Power Connector
Extension	P4	100	4	Peripheral Power Connector
Extension from P4	P5	100	4	Floppy Power Connector
Power Supply cover exit hole	P6	890	4	Peripheral Power Connector
Extension	P7	75	4	Peripheral Power Connector
Power Supply cover exit hole	P8	75	4	Peripheral Power Connector
Extension	P9	75	4	Peripheral Power Connector

From	To Connector #	Length (mm)	No of Pins	Description
Power Supply cover exit hole	P10	890	5	Right-angle SATA Power Connector
Extension	P11	75	5	SATA Power Connector

2.1.3.1 P1 Baseboard Power Connector

Connector: Molex* 39-01-2240 or approved equivalent

Contacts: Molex 39-00-0038, or AMP 794416-1 or approved equivalent

Mating Connector: Molex 39-29-9202 or AMP 794311-1 or approved equivalent

Table 4. P1 Baseboard Power Connector

Pin	Signal	18 AWG Color	Pin	Signal	18 AWG Color
1	+3.3 VDC	Orange	13	+3.3 VDC	Orange (22 AWG)
			13	+3.3 V Sense	Brown (22 AWG)
2	+3.3 VDC	Orange	14	-12 VDC	Blue
3	COM	Black	15	COM	Black
4	+5 VDC	Red	16	PSO#	Green
5	COM	Black	17	COM	Black
6	+5 VDC	Red	18	COM	Black
7	COM	Black	19	COM	Black
8	PWR OK	Gray	20	Reserved	N.C.
9	5VSB	Purple	21	+5 VDC	Red
10	+12V1	Yellow	22	+5 VDC	Red
11	+12V1	Yellow	23	+5 VDC	Red
12	+3.3 VDC	Orange	24	COM	Black

2.1.3.2 P2 Processor Power Connector

Connector housing: 8-Pin Molex 39-01-2085 or equivalent

Contact: Molex 44476-1111 or Molex 5556 as the alternative or equivalent approved by Intel

Table 5. P2 Processor Power Connector

Pin	Signal	18 AWG Color	Pin	Signal	18 AWG Color
1	COM	Black	5	+12V2	Yellow
2	COM	Black	6	+12V2	Yellow
3	N.C.		7	N.C.	
4	N.C.		8	N.C.	

2.1.3.3 P3-P4, P6-P9 Peripheral Connectors

Connector: AMP* 1-480424-0 or Molex 8981-04P (15-24-4048) or approved equivalent

Contacts: AMP 61117-1, Molex 02-08-1215 terminals, or approved equivalent

Mating connector: Molex 8981-04P (15-24-4048) or AMP 1-480424-0 or approved equivalent.

Table 6. P3-P6, P8-P9 Peripheral Connectors

Pin	Signal	18 AWG Color
1	+12V1	Yellow
2	COM	Black
3	COM	Black
4	+5 VDC	Red

2.1.3.4 P5 Floppy Power Connector

Connector: AMP 171822-4 or approved equivalent

Contacts: AMP 170262-1 or approved equivalent

Mating connector: AMP 171822-4 or approved equivalent

Table 7. P5 Floppy Power Connector

Pin	Signal	18 AWG Color
1	+5 VDC	Red
2	COM	Black
3	COM	Black
4	+12V1	Yellow

2.1.3.5 P10-P11 SATA Power Connectors

- Connector Housing:
- Contact:

Table 8. P11 SATA Power Connector

Pin	Signal	18 AWG Color
1	+3.3Vdc	Orange
2	COM	Black
3	+5Vdc	Red
4	COM	Black
5	+12V1	Yellow

2.1.4 AC Input Requirements

The power supply performs power factor correction for 230Vac input, which shall reduce line harmonics in accordance with the EN61000-3-2.

Table 9. AC Input Rating

PARAMETER	MIN	RATED	MAX	Max Input Current	Start up VAC	Power Off VAC
Voltage (110)	90 V _{rms}	100-127 V _{rms}	140 V _{rms}	10 A ^{1,3}	85Vac +/- 4Vac	75Vac +/- 5Vac
Voltage (220)	180 V _{rms}	200-240 V _{rms}	264 V _{rms}	5 A ^{2,3}		
Frequency	47 Hz	50/60	63 Hz			

1 Maximum input current at low input voltage range is measured at 90VAC, at max load.

2 Maximum input current at high input voltage range is measured at 180VAC, at max load.

3 This requirement is not to be used for determining agency input current markings.

2.1.4.1 AC Inlet Connector

The AC input connector is an IEC 320 C-14 power inlet. This inlet is rated for 10A / 250VAC.

2.1.4.2 Efficiency

The power supply has an efficiency of 68% at maximum load and over the specified AC voltage.

2.1.4.3 AC Line Dropout / Holdup

An AC line dropout is defined to be when the AC input drops to 0VAC at any phase of the AC line for any length of time. During an AC dropout the power supply meets dynamic voltage regulation requirements. An AC line dropout of any duration does not cause tripping of control signals or protection circuits. If the AC dropout lasts longer than the hold up time, the power supply will recover and meet all turn on requirements. The power supply meets the AC dropout requirement over rated AC voltages and frequencies. A dropout of the AC line for any duration does not cause damage to the power supply.

2.1.4.4 AC Line Fuse

The power supply has a single line fuse, on the Line (Hot) wire of the AC input. The line fusing is acceptable for all safety agency requirements. The input fuse is a slow blow type. AC inrush current does not cause the AC line fuse to blow under any conditions. All protection circuits in the power supply does not cause the AC fuse to blow unless a component in the power supply has failed. This includes DC output load short conditions.

2.1.4.5 AC Inrush

Peak inrush current will not damage the PSU or the input fuse will not blow under any conditions of load, temperature and input voltage including repeated, rapid cycling of the power line.

2.1.4.6 AC Line Transient Specification

AC line transient conditions are defined as “sag” and “surge” conditions. “Sag” conditions are also commonly referred to as “brownout”, these conditions will be defined as the AC line voltage dropping below nominal voltage conditions. “Surge” will be defined to refer to conditions when the AC line voltage rises above nominal voltage.

The power supply meets the requirements under the AC line sag and surge conditions defined in the following tables.

Table 10. AC Line Sag Transient Performance

Duration	Sag	Operating AC Voltage	Line Frequency	Performance Criteria
0 to 1 AC cycle	95%	Nominal AC Voltage ranges	50/60Hz	No loss of function or performance
> 1 AC cycle	>30 %	Nominal AC Voltage ranges	50/60Hz	Loss of function acceptable, self recoverable

Table 11. AC Line Surge Transient Performance

Duration	Surge	Operating AC Voltage	Line Frequency	Performance Criteria
Continuous	10%	Nominal AC Voltages	50/60Hz	No loss of function or performance
0 to ½ AC cycle	30%	Mid-point of nominal AC Voltages	50/60Hz	No loss of function or performance

2.1.4.7 AC Line Fast Transient (EFT) Specification

The power supply meets the EN61000-4-5 directive and any additional requirements in IEC1000-4-5: 1995 and the Level 3 requirements for surge-withstand capability, with the following conditions and exception:

- These input transients do not cause any out-of-regulation conditions, such as overshoot and undershoot, nor do they cause any nuisance trips of any of the power supply protection circuits
- The surge-withstand test does not produce damage to the power supply.
- The supply meets surge-withstand test conditions under maximum and minimum DC-output load conditions.

2.1.4.8 AC Line Leakage Current

The maximum leakage current to ground for each power supply is 3.5mA when tested at 240VAC.

2.1.5 DC Output Specifications

2.1.5.1 Grounding

The ground of the pins of the power supply output connector provides the power return path. The output connector ground pins are connected to safety ground (power supply enclosure).

The power supply needs a reliable protective earth ground. All secondary circuits are connected to protective earth ground. Resistance of the ground returns to the chassis do not exceed 1.0 mΩ. This path may be used to carry DC current.

2.1.5.2 Standby Output

The 5VSB output is present when an AC input greater than the power supply turn on voltage is applied.

2.1.5.3 Remote Sense

The power supply has remote sense return (ReturnS) to regulate out ground drops for +3.3V. The power supply uses remote sense to regulate out drops in the system for the +3.3V. The

power supply operates within specification over the full range of voltage drops from the power supply's output connector to the remote sense points.

2.1.5.4 Power Module Output Power / Currents

The following table defines power and current ratings for this 350-W power supply. The combined output power of all outputs does not exceed the rated output power. The power supply meets both static and dynamic voltage regulation requirements for the minimum loading conditions.

Table 12. Load Ratings

Output Voltage	Load Range		Peak
	Min.	Max.	
1. +5V	1A	21A	
2. +12V1	0.5A	10A	12A
3. +12V2	0.5A	16A	19A
4. +3.3V	0A	22A	
5. -12V	0.0A	0.8A	
6. +5V _{stb}	0.5A	2A	2.5A

Notes:

- 1) Max continuous output power rating of supply is 350 W at 25°C, de-rate 2W/°C from 25°C to 50°C to yield a maximum continuous power rating of 300 W at 50°C.
- 2) Max combined power of 12V1 and 12V2 does not exceed 300 W.
- 3) Max combined power on 3.3V and 5V equal to 130 W with current values not exceeding max values of load condition
- 4) The peak current will last for less than 8 sec.

2.1.5.5 Voltage Regulation

The power supply output voltages stay within the following voltage limits when operating at steady state and dynamic loading conditions. These limits include the peak-peak ripple/noise. All outputs are measured with reference to the return remote sense signal (ReturnS).

Table 13. Voltage Regulation Limits

PARAMETER	TOLERANCE	MIN	NOM	MAX	UNITS
+ 3.3V	- 5% / +5%	+3.14	+3.30	+3.46	V _{rms}
+ 5V	- 5% / +5%	+4.75	+5.00	+5.25	V _{rms}

PARAMETER	TOLERANCE	MIN	NOM	MAX	UNITS
+ 12V1	- 5% / +5%	+11.40	+12.00	+12.60	V _{rms}
+ 12V2	- 5% / +5%	+11.40	+12.00	+12.60	V _{rms}
- 12V	- 10% / +10%	-13.20	-12.00	-10.80	V _{rms}
+ 5VSB	- 5% / +5%	+4.75	+5.00	+5.25	V _{rms}

2.1.5.6 Dynamic Loading

The output voltages are within limits specified for the step loading and capacitive loading specified in the following table. The Δ step load may occur anywhere within the MIN load to the MAX load conditions.

Table 14. Transient Load Requirements

Output	Δ Step Load Size ¹	Load Slew Rate	Test capacitive Load
+3.3V	5.0A	0.25 A/ μ sec	2200 μ F
+5V	6.0A	0.25 A/ μ sec	2200 μ F
+12V1	2.5A	0.25 A/ μ sec	2200 μ F
+12V2	11A	0.25 A/ μ sec	2200 μ F
+5VSB	0.5A	0.25 A/ μ sec	350 μ F

Note:

1. Step loads on each 12V output may happen simultaneously.

2.1.5.7 Capacitive Loading

The power supply is stable and meets all requirements with the following capacitive loading ranges.

Table 15. Capacitive Loading Conditions

Output	MIN	MAX	Units
+3.3V	250	2200	μ F
+5V	400	2200	μ F
+12V	500	2200	μ F
-12V	1	350	μ F

+5VSB	20	350	μF
-------	----	-----	----

2.1.5.8 Closed loop stability

The power supply is unconditionally stable under all line/load/transient load conditions, including capacitive load ranges. A minimum of: **45 degrees phase margin** and **-10dB-gain margin** is required. Closed-loop stability is ensured at the maximum and minimum loads as applicable.

2.1.5.9 Ripple / Noise

The maximum allowed ripple/noise output of the power supply is defined in the table below. This is measured over a bandwidth of 10Hz to 20MHz at the power supply output connectors. A 10μF tantalum capacitor in parallel with a 0.1μF ceramic capacitor is placed at the point of measurement.

Table 16. Ripple and Noise

+3.3V	+5V	+12V1/2	-12V	+5VSB
50mVp-p	50mVp-p	120mVp-p	120mVp-p	50mVp-p

2.1.5.10 Timing Requirements

The power supply has the following timing requirements. The output voltages must rise from 10% to within regulation limits (T_{vout_rise}) within 0.2 to 20ms, except for 5VSB which is allowed to rise from 0.2 to 25ms. The +3.3V, +5V and +12V output voltages should start to rise approximately at the same time. All outputs must rise monotonically. The 3.3V output will not be greater than the +5V output by 1.5V during any point of the voltage rise condition. The +5V output must never be greater than the +3.3V output by more than 2.25V. Each output voltage reaches regulation within 50ms (T_{vout_on}) of each other during turn on of the power supply. Each output voltage shall fall out of regulation within 400msec (T_{vout_off}) of each other during turn off. Table 18 shows the timing requirements for the power supply being turned on and off via the AC input, with PSON held low and the PSON signal, with the AC input applied.

Table 17. Output Voltage Timing

Item	Description	Minimum	Maximum	Units
T_{vout_rise}	Output voltage rise time from each main output.	0.2 *	20 *	msec
T_{vout_on}	All main outputs must be within regulation of each other within this time.		50	msec
T_{vout_off}	All main outputs must leave regulation within this time.		400	msec

* The 5VSB output voltage rise time shall be from 0.2 ms to 25 ms

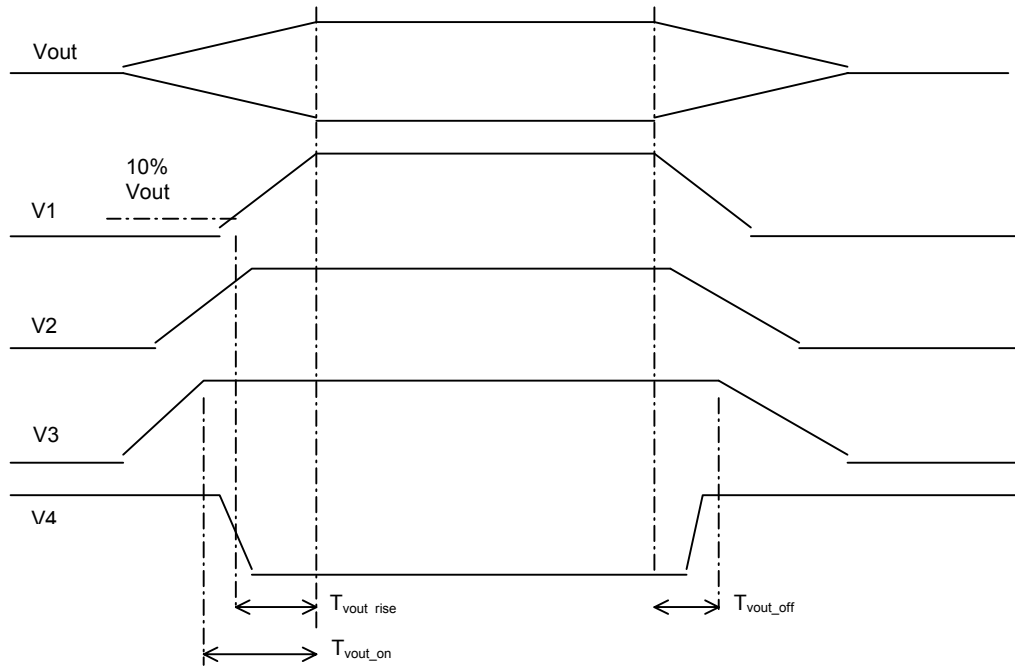

Figure 8. Output Voltage Timing

Table 18. Turn On / Off Timing

Item	Description	Minimum	Maximum	Units
T _{sb_on_delay}	Delay from AC being applied to 5VSB being within regulation.		1500	msec
T _{ac_on_delay}	Delay from AC being applied to all output voltages being within regulation.		2500	msec
T _{vout_holdup}	Time all output voltages stay within regulation after loss of AC.	10		msec
T _{pwok_holdup}	Delay from loss of AC to de-assertion of PWOK	10		msec
T _{pson_on_delay}	Delay from PSON# active to output voltages within regulation limits.	5	400	msec
T _{pson_pwok}	Delay from PSON# deactive to PWOK being de-asserted.		50	msec
T _{pwok_on}	Delay from output voltages within regulation limits to PWOK asserted at turn on.	100	1000	msec
T _{pwok_off}	Delay from PWOK de-asserted to output voltages (3.3V, 5V, 12V, -12V) dropping out of regulation limits.	1		msec

Item	Description	Minimum	Maximum	Units
T _{pwok_low}	Duration of PWOK being in the de-asserted state during an off/on cycle using AC or the PSON signal.	100		msec
T _{sb_vout}	Delay from 5VSB being in regulation to O/Ps being in regulation at AC turn on.	50	1000	msec
T _{5VSB_holdup}	Time the 5VSB output voltage stays within regulation after loss of AC.	70		msec

2.1.5.11 Residual Voltage Immunity in Standby Mode

The power supply is immune to any residual voltage placed on its outputs (Typically a leakage voltage through the system from standby output) up to 500mV. There is neither additional heat generated, nor stress of any internal components with this voltage applied to any individual output, and all outputs simultaneously. It also does not trip the protection circuits during turn on.

The residual voltage at the power supply outputs for no load condition does not exceed 100mV when AC voltage is applied and the PSON# signal is de-asserted.

2.1.6 Protection Circuits

Protection circuits inside the power supply cause only the power supply's main outputs to shutdown. If the power supply latches off due to a protection circuit tripping, an AC cycle OFF for 15sec and a PSON# cycle HIGH for 1sec will reset the power supply.

2.1.6.1 Over-Current Protection (OCP)

Overload currents at each output rail will cause the output to trip before they reach or exceed 240 VA. If the current limits are exceeded the power supply shall shutdown and latch off. The latch will be cleared by toggling the PSON# signal or by an AC power interruption. The power supply will not be damaged from repeated power cycling in this condition. -12V and 5VSB are protected under over current or shorted conditions so that no damage can occur to the power supply. 5Vsb will be auto-recovered after removing OCP limit.

2.1.6.2 Over Voltage Protection (OVP)

The power supply over voltage protection is locally sensed. The power supply will shutdown and latch off after an over voltage condition occurs. This latch can be cleared by toggling the PSON# signal or by an AC power interruption. The following table contains the over voltage limits. The values are measured at the output of the power supply's connectors. The voltage never exceeds the maximum levels when measured at the power pins of the power supply connector during any single point of fail. The voltage will not trip any lower than the minimum levels when measured at the power pins of the power supply connector.

Exception: +5VSB rail will recover after its over voltage condition occurs.

Table 19. Over Voltage Protection Limits

Output Voltage	MIN (V)	MAX (V)
+3.3V	3.9	4.5
+5V	5.7	6.5
+12V1,2	13.3	14.5
-12V	-13.3	-16.0
+5VSB	5.7	6.5

2.1.6.3 Over Temperature Protection (OTP)

The power supply is protected against over temperature conditions caused by loss of fan cooling or excessive ambient temperature. In an OTP condition the PSU will shutdown.

2.1.6.4 PSON# Input Signal

The PSON# signal is required to remotely turn on/off the power supply. PSON# is an active low signal that turns on the +3.3V, +5V, +12V, and -12V power rails. When this signal is not pulled low by the system, or left open, the outputs (except the +5VSB) turn off. This signal is pulled to a standby voltage by a pull-up resistor internal to the power supply.

Table 20. PSON# Signal Characteristic

Signal Type	Accepts an open collector/drain input from the system. Pull-up to VSB located in power supply.	
PSON# = Low	ON	
PSON# = High or Open	OFF	
	MIN	MAX
Logic level low (power supply ON)	0V	1.0V
Logic level high (power supply OFF)	2.0V	5.25V
Source current, $V_{pson} = \text{low}$		4mA
Power up delay: $T_{pson_on_delay}$	5msec	400msec
PWOK delay: T_{pson_pwok}		50msec

2.1.6.5 PWOK (Power OK) Output Signal

PWOK is a power OK signal and is pulled high by the power supply to indicate that all the outputs are within the regulation limits of the power supply. When any output voltage falls below regulation limits or when AC power has been removed for a time sufficiently long so that power supply operation is no longer guaranteed, PWOK will be de-asserted to a low state. The start of the PWOK delay time is inhibited as long as any power supply output is in current limit.

Table 21. PWOK Signal Characteristics

Signal Type	Open collector/drain output from power supply. Pull-up to VSB located in system.	
PWOK = High	Power OK	
PWOK = Low	Power Not OK	
	MIN	MAX
Logic level low voltage, $I_{sink}=4mA$	0V	0.4V
Logic level high voltage, $I_{source}=200\mu A$	2.4V	5.25V
Sink current, PWOK = low		4mA
Source current, PWOK = high		2mA
PWOK delay: T_{pwok_on}	100ms	1000ms
PWOK rise and fall time		100 μ sec
Power down delay: T_{pwok_off}	1ms	200msec

2.2 420-Watt Power Supply

The 420-W power supply specification defines a non-redundant power supply that supports DP Intel® Xeon™ entry server systems. The 420-W power supply has 6 outputs: 3.3V, 5V, 12V1, 12V2, -12V and 5VSB. The form factor fits into a pedestal system and provides a wire harness output to the system. An IEC connector is provided on the external face for AC input to the power supply.

The power supply incorporates a Power Factor Correction circuit. The power supply is tested as described in EN 61000-3-2: Electromagnetic Compatibility (EMC) Part 3: Limits- Section 2: Limits for harmonic current emissions and meets the harmonic current emissions limits specified for ITE equipment.

The power supply is tested as described in JEIDA MITI Guideline for Suppression of High Harmonics in Appliances and General-Use Equipment and meets the harmonic current emissions limits specified for ITE equipment.

2.2.1 Mechanical Overview

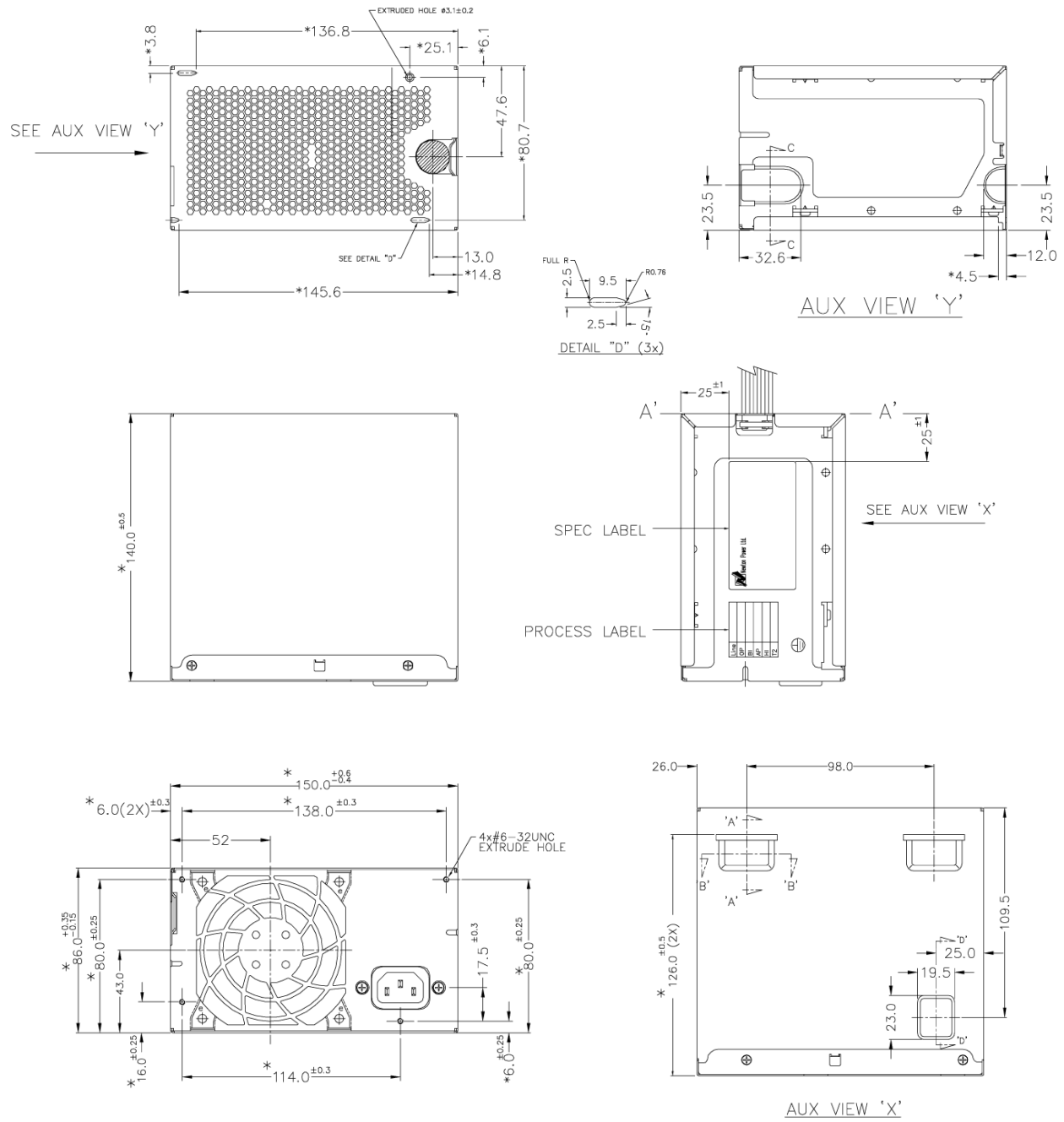

Figure 9. Mechanical Drawing for Power Supply Enclosure

2.2.2 Airflow and Temperature

The power supply operates within all specified limits over the T_{op} temperature range. The average air temperature difference (ΔT_{ps}) from the inlet to the outlet of the power supply does not exceed 20C. All airflow passes through the power supply and not over the exterior surfaces of the power supply.

Table 22. Environmental Requirements

ITEM	DESCRIPTION	MIN	Specification	UNITS
T_{op}	Operating temperature range.	0	50	°C
T_{non-op}	Non-operating temperature range.	-40	70	°C
Altitude	Maximum operating altitude		1500	m

The power supply meets UL enclosure requirements for temperature rise limits. All sides of the power supply, with exception to the air exhaust side, are classified as “Handle, knobs, grips, etc. held for short periods of time only”.

2.2.3 Output Cable Harness

Listed or recognized component appliance wiring material (AVLV2), CN, rated min 105°C, 300Vdc is used for all output wiring.

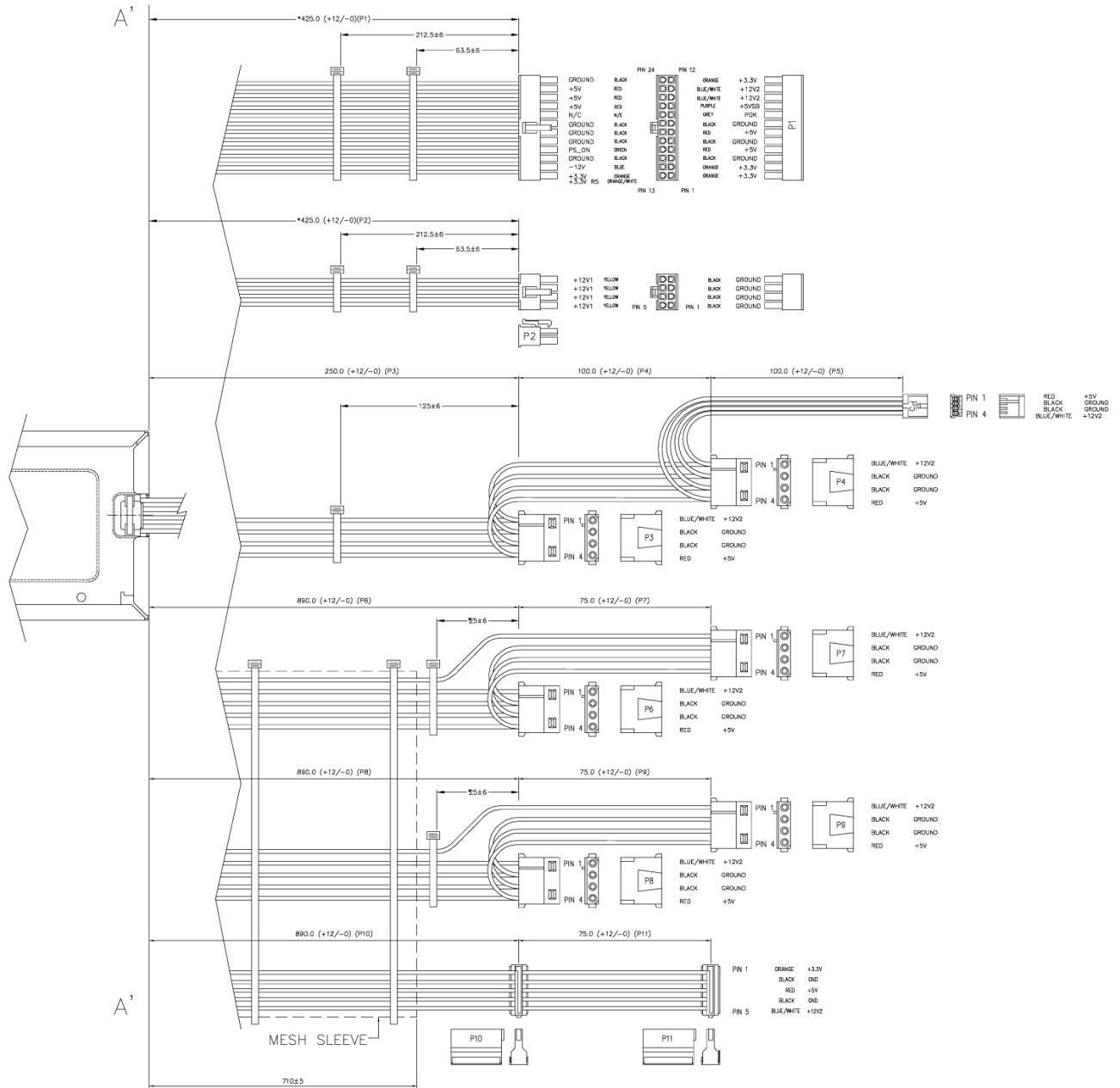

Figure 10. Output Cable Harness for 420-W Power Supply

NOTES:

1. ALL DIMENSIONS ARE IN MM
2. ALL TOLERANCES ARE +10 MM / -0 MM
3. INSTALL 1 TIE WRAP WITHIN 12MM OF THE PSU CAGE
4. MARK REFERENCE DESIGNATOR ON EACH CONNECTOR
5. TIE WRAP EACH HARNESS AT APPROX. MID POINT
6. TIE WRAP P1 WITH 2 TIES AT APPROXIMATELY 15M SPACING.

Table 23. Cable Lengths

From	To connector #	Length (mm)	No. of pins	Description
Power Supply cover exit hole	P1	425	24	Baseboard Power Connector
Power Supply cover exit hole	P2	425	8	Processor Power Connector
Power Supply cover exit hole	P3	250	4	Peripheral Power Connector
Extension	P4	100	4	Peripheral Power Connector
Extension from P4	P5	100	4	Floppy Power Connector
Power Supply cover exit hole	P6	890	4	Peripheral Power Connector
Extension	P7	75	4	Peripheral Power Connector
Power Supply cover exit hole	P8	890	4	Peripheral Power Connector
Extension	P9	75	4	Peripheral Power Connector
Power Supply cover exit hole	P10	890	5	Right-angle SATA Power Connector
Extension	P11	75	5	SATA Power Connector

2.2.3.1 P1 Baseboard Power Connector

Connector housing: 24- Pin Molex Mini-Fit Jr. 39-01-2245 or equivalent

Contact: Molex Mini-Fit, HCS, Female, Crimp 44476 or equivalent

Table 24. P1 Baseboard Power Connector

PIN	SIGNAL	18 AWG COLOR	PIN	SIGNAL	18 AWG COLOR
1	+3.3 VDC	Orange	13	+3.3 VDC*	Orange
2	+3.3 VDC	Orange	14	-12 VDC	Blue
3	COM	Black	15	COM	Black
4	+5 VDC	Red	16	PSO#	Green
5	COM	Black	17	COM	Black

PIN	SIGNAL	18 AWG COLOR	PIN	SIGNAL	18 AWG COLOR
6	+5 VDC	Red	18	COM	Black
7	COM	Black	19	COM	Black
8	PWR OK	Gray	20	Reserved	N.C.
9	5VSB	Purple	21	+5 VDC	Red
10	+12V2	White/Blue Stripe	22	+5 VDC	Red
11	+12V2	White/Blue Stripe	23	+5 VDC	Red
12	+3.3 VDC	Orange	24	COM	Black

Note:

- 3.3V Locate Sense Double Crimped into pin 13. (with #22 AWG Orange/White stripe wire)

2.2.3.2 P2 Processor Power Connector

Connector housing: 8- Pin Molex 39-01-2085 or equivalent

Contact: Molex 44476-1111 or equivalent

Table 25. P2 Processor Power Connector

PIN	SIGNAL	18 AWG COLOR	PIN	SIGNAL	18 AWG COLOR
1	COM	Black	5	+12V1	Yellow
2	COM	Black	6	+12V1	Yellow
3	COM	Black	7	+12V1	Yellow
4	COM	Black	8	+12V1	Yellow

2.2.3.3 P3-P9 Peripheral Connectors

Connector housing: AMP V0 P/N is 770827-1 or equivalent

Contact: Amp 61314-1 contact or equivalent

Table 26. P3-P6, P8-P9 Peripheral Connectors

Pin	Signal	18 AWG Color
1	+12 V2	Blue / White
2	COM	Black
3	COM	Black
4	+5 VDC	Red

2.2.3.4 P10 Right-angle, P11 SATA Power Connectors

Connector Housing:
Contact:

Table 27. P10 Right-angle SATA Power Connector

Pin	Signal	24 AWG Color
1	+3.3V	Orange
2	Ground	Black
3	+5V	Red
4	Ground	Black
5	+12V2	Blue/White

2.2.4 AC Input Requirements

The power supply operates within all specified limits over the following input voltage range, shown in the following table. Harmonic distortion of up to 10% THD must not cause the power supply to go out of specified limits. The power supply does power off if the AC input is less than 75VAC +/-5VAC range. The power supply starts up if the AC input is greater than 85VAC +/-4VAC. Application of an input voltage below 85VAC does not cause damage to the power supply, including a fuse blow.

Table 28. AC Input Rating

PARAMETER	MIN	RATED	MAX	Max Input Current	Start up VAC	Power Off VAC
Voltage (110)	90 V _{rms}	100-127 V _{rms}	135 V _{rms}	7.7 A _{rms}	85Vac +/-4Vac	75Vac +/-5Vac
Voltage (220)	180 V _{rms}	200-240 V _{rms}	265 V _{rms}	4.3 A _{rms}		
Frequency	47 Hz		63 Hz			

2.2.4.1 AC Inlet Connector

The AC input connector is an IEC 320 C-14 power inlet. This inlet is rated for 15A / 250VAC.

2.2.4.2 Efficiency

The power supply has an efficiency of 68.5% at maximum load and over the specified AC voltage.

2.2.4.3 AC Line Dropout / Holdup

An AC line dropout is defined to be when the AC input drops to 0VAC at any phase of the AC line for any length of time. During an AC dropout of one cycle or less the power supply meets dynamic voltage regulation requirements over the rated load. An AC line dropout of one cycle or less (20ms min) does not cause any tripping of control signals or protection circuits (= 20ms holdup time requirement). If the AC dropout lasts longer than one cycle the power will recover and meet all turn on requirements. The power supply meets the AC dropout requirement over rated AC voltages, frequencies, and output loading conditions. Any dropout of the AC line does not cause damage to the power supply.

2.2.4.3.1 AC Line 5VSB Holdup

The 5VSB output voltage stays in regulation under its full load (static or dynamic) during an AC dropout of 70ms min (=5VSB holdup time) whether the power supply is in ON or OFF state (PSON asserted or de-asserted).

2.2.4.4 AC Line Fuse

The power supply has a single line fuse, on the Line (Hot) wire of the AC input. The line fusing is acceptable for all safety agency requirements. The input fuse is a slow blow type. AC inrush current does not cause the AC line fuse to blow under any conditions. All protection circuits in the power supply does not cause the AC fuse to blow unless a component in the power supply has failed. This includes DC output load short conditions.

2.2.4.5 AC Inrush

AC line inrush current does not exceed 65A peak for up to 10ms, after which, the input current is no more than the specified maximum input current at 265Vac input, 25 degree C and full load. The peak inrush current is less than the ratings of its critical components (including input fuse, bulk rectifiers, and surge limiting device). For 10ms to 150ms .the inrush current should be less than 25A peak.

The power supply meets the inrush requirements for any rated AC voltage during turn on at any phase of AC voltage, during a single cycle AC dropout condition as well as upon recovery after AC dropout of any duration, and over the specified temperature range (T_{op}). AC line inrush current may reach up to 60A peak for up to 1ms.

2.2.4.6 AC Line Surge

The power supply is tested with the system for immunity to AC Ringwave and AC Unidirectional wave, both up to 2kV, per EN 55024:1998, EN 61000-4-5:1995 and ANSI C62.45: 1992.

The power supply complies with the limits defined in EN55024: 1998 using the IEC 61000-4-5:1995 test standard and performance criteria B defined in Annex B of CISPR 24.

2.2.4.7 AC Line Transient Specification

AC line transient conditions are defined as “sag” and “surge” conditions. “Sag” conditions are also commonly referred to as “brownout”, these conditions will be defined as the AC line voltage dropping below nominal voltage conditions. “Surge” will be defined to refer to conditions when the AC line voltage rises above nominal voltage.

The power supply meets the requirements under the following AC line sag and surge conditions:

Table 29. AC Line Sag Transient Performance

Duration	Sag	Operating AC Voltage	Line Frequency	Performance Criteria
Continuous	10%	Nominal AC Voltage ranges	50/60Hz	No loss of function or performance
0 to 1 AC cycle	100 %	Nominal AC Voltage ranges	50/60Hz	No loss of function or performance
> 1 AC cycle	>10 %	Nominal AC Voltage ranges	50/60Hz	Loss of function acceptable, self recoverable

Table 30. AC Line Surge Transient Performance

Duration	Surge	Operating AC Voltage	Line Frequency	Performance Criteria
Continuous	10%	Nominal AC Voltages	50/60Hz	No loss of function or performance
0 to ½ AC cycle	30%	Mid-point of nominal AC Voltages	50/60Hz	No loss of function or performance

2.2.4.8 AC Line Fast Transient (EFT) Specification

The power supply meets the EN61000-4-5 directive and any additional requirements in IEC1000-4-5:1995 and the Level 3 requirements for surge-withstand capability, with the following conditions and exception:

These input transients do not cause any out-of-regulation conditions, such as overshoot and undershoot, nor do they cause any nuisance trips of any of the power supply protection circuits

The supply meets surge-withstand test conditions under maximum and minimum DC-output load conditions.

2.2.4.9 AC Line Leakage Current

The maximum leakage current to ground for each power supply is 3.5mA when tested at 240VAC.

2.2.5 DC Output Specifications

2.2.5.1 Grounding

The ground of the pins of the power supply output connector provides the power return path. The output connector ground pins are connected to safety ground (power supply enclosure).

2.2.5.2 Standby Output

The 5VSB output is present when an AC input greater than the power supply turn on voltage is applied.

2.2.5.3 Remote Sense

The power supply has remote sense return (ReturnS) to regulate out ground drops for all output voltages; +3.3V, +5V, +12V1, +12V2, -12V, and 5VSB. The power supply uses remote sense (3.3VS) to regulate out drops in the system for the +3.3V output. The +5V, +12V1, +12V2, -12V and 5VSB outputs only use remote sense referenced to the ReturnS signal. The remote sense input impedance to the power supply is greater than 200Ω on 3.3VS, 5VS. This is the value of the resistor connecting the remote sense to the output voltage internal to the power supply. Remote sense is able to regulate out a minimum of 200mV drop on the +3.3V output. The remote sense return (ReturnS) is able to regulate out a minimum of 200mV drop in the power ground return. The current in any remote sense line is less than 5mA to prevent voltage sensing errors. The power supply operates within specification over the full range of voltage drops from the power supply's output connector to the remote sense points.

2.2.5.4 Power Module Output Power / Currents

The following table defines power and current ratings for this 420-W power supply. The combined output power of all outputs does not exceed the rated output power. The power supply meets both static and dynamic voltage regulation requirements for the minimum loading conditions.

Table 31. Load Ratings

Output Voltage	Load Range		Regulation	Ripple and Noise Max. mV P-P
	Min.	Max.		
+5V	2A	20A	4.80 - 5.25V	50mV
+3V3	0.5A	17A	3.135 - 3.47V	50mV
-12V	0A	0.5A	-11.52 - -12.6V	120mV
+5VSB	0A	2A	4.80 - 5.25V	70mV
+12V1	0.5A	24A	11.40 - 12.6V	120mV
+12V2	0.5A	17A	11.40 - 12.6V	120mV

Notes:

- Noise test: noise bandwidth is from 10 Hz to 20 MHz.

2. Add 0.1 uF and 10uF low ESR capacitors at output connector terminals for ripple and noise measurements.
3. Main O/P shall be enabled by pulled “remote” pin to TTL low level, and disabled by pulled “remote” pin to TTL high level.
4. Max combined power on +5V and +3.3V outputs does not exceed 150 W.
5. 12V1 and 12V2 combined current does not exceed 30A
6. 12V1 and 12V2 combine peak current does not exceed 34 A for over 12 seconds.
7. All outputs remain within regulation limits.
8. Maximum power does not exceed 450 W at 25 degrees C ambient and 420 W at 50 degrees C ambient.

2.2.5.5 Voltage Regulation

The power supply output voltages are within the following voltage limits when operating at steady state and dynamic loading conditions. These limits include the peak-peak ripple/noise. All outputs are measured with reference to the return remote sense signal (ReturnS). The 5V, 12V1, 12V2, -12V and 5VSB outputs are measured at the power supply connectors referenced to ReturnS. The +3.3V is measured at the remote sense signal (3.3VS) located at the signal connector.

Table 32. Voltage Regulation Limits

Parameter	Tolerance	MIN	NOM	MAX	Units
+ 3.3V	- 5% / +5%	+3.135	+3.30	+3.47	V _{rms}
+ 5V	- 4% / +5%	+4.80	+5.00	+5.25	V _{rms}
+ 12V1	- 5% / +5%	+11.40	+12.00	+12.60	V _{rms}
+ 12V2	- 5% / +5%	+11.40	+12.00	+12.60	V _{rms}
- 12V	- 5% / +4%	-11.52	-12.00	-12.60	V _{rms}
+ 5VSB	- 4% / +5%	+4.80	+5.00	+5.25	V _{rms}

2.2.5.6 Dynamic Loading

The output voltages are within limits specified for the step loading and capacitive loading specified in the following table. The Δ step load may occur anywhere within the MIN load to the MAX load conditions.

Table 33. Transient Load Requirements

Parameter	Output Range	MAX Step	Voltage Overshoot / Undershoot
+12V1DC	0.5A TO 18A	6A	±350mV (700mVpk-pk)
+12V2DC	0.5A TO 15A	6A	±350mV (700mVpk-pk)

Parameter	Output Range	MAX Step	Voltage Overshoot / Undershoot
+5VDC	2A TO 20A	5A	±200mV(400mVpk-pk)
+3.3VDC	0.5A TO 17A	6A	±200mV (400mVpk-pk)
+5VSB	0.1A TO 2.0A	0.7A	±250mV(500mVpk-pk)

2.2.5.7 Capacitive Loading

The power supply is stable and meets all requirements with the following capacitive loading ranges.

Table 34. Capacitive Loading Conditions

Output	MIN	MAX	Units
+3.3V	250	6,800	μF
+5V	400	4,700	μF
+12V(1, 2)	500 each	11,000	μF
-12V	1	350	μF
+5VSB	20	350	μF

2.2.5.8 Closed Loop Stability

The power supply is unconditionally stable under all line/load/transient load conditions, including capacitive load ranges. A minimum of: 45 degrees phase margin and -8dB-gain margin is required. Closed-loop stability is ensured at the maximum and minimum loads as applicable.

2.2.5.9 Ripple / Noise

The maximum allowed ripple/noise output of the power supply is defined in the following table. This is measured over a bandwidth of 0 Hz to 20 MHz at the power supply output connectors.

Table 35. Ripple and Noise

+3.3V	+5V	+12V1/2	-12V	+5VSB
50mVp-p	50mVp-p	120mVp-p	120mVp-p	50mVp-p

2.2.5.10 Timing Requirements

The timing requirements for power supply operation are as follows. The output voltages must rise from 10% to within regulation limits (T_{vout_rise}) within 2 to 20ms, except for 5VSB - it is allowed to rise from 1.0 to 70ms. The +3.3V, +5V and +12V output voltages should start to rise approximately at the same time. All outputs must rise monotonically. The +5V output needs to be greater than the +3.3V output during any point of the voltage rise. The +5V output must never be greater than the +3.3V output by more than 2.25V. Each output voltage shall reach regulation within 50ms (T_{vout_on}) of each other during turn on of the power supply. Each output voltage shall fall out of regulation within 400msec (T_{vout_off}) of each other during turn off. The following figure shows the timing requirements for the power supply being turned on and off via the AC input, with PSON held low and the PSON signal, with the AC input applied.

Table 36. Output Voltage Timing

Item	Description	Minimum	Maximum	Units
T_{vout_rise}	Output voltage rise time from each main output.	2.0 *	20 *	msec
T_{vout_on}	All main outputs must be within regulation of each other within this time.		50	msec
T_{vout_off}	All main outputs must leave regulation within this time.		400	msec

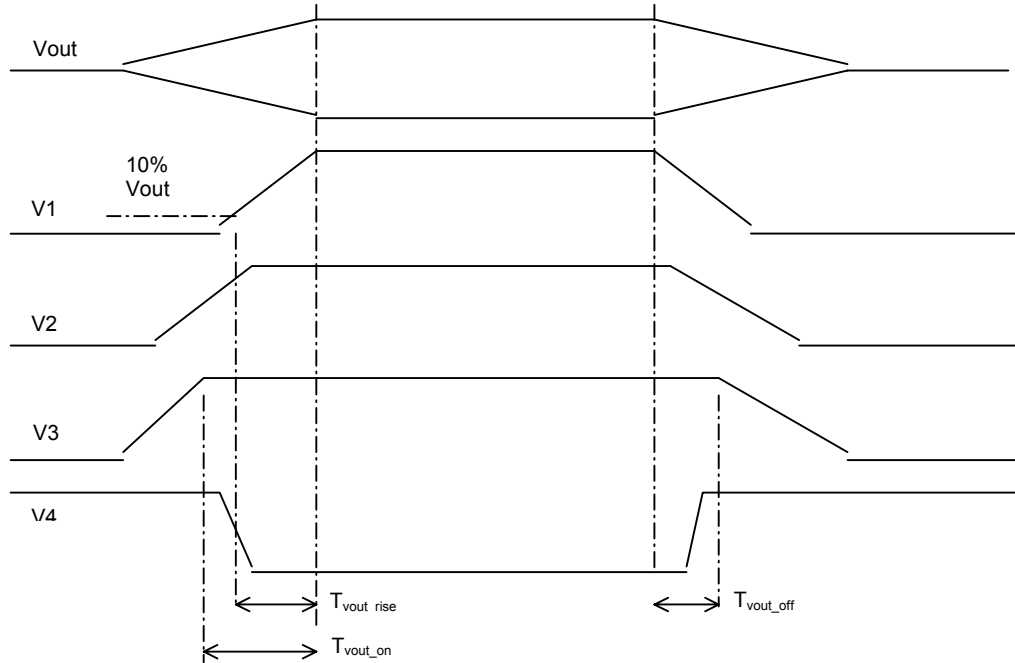

Figure 11. Output Voltage Timing

Table 37. Turn On / Off Timing

Item	Description	Minimum	Maximum	Units
T _{sb_on_delay}	Delay from AC being applied to 5VSB being within regulation.		1000	msec
T _{ac_on_delay}	Delay from AC being applied to all output voltages being within regulation.		2500	msec
T _{vout_holdup}	Time all output voltages stay within regulation after loss of AC.	21		msec
T _{pwok_holdup}	Delay from loss of AC to de-assertion of PWOK	20		msec
T _{pson_on_delay}	Delay from PSON# active to output voltages within regulation limits.	5	400	msec
T _{pson_pwok}	Delay from PSON# deactive to PWOK being de-asserted.		50	msec
T _{pwok_on}	Delay from output voltages within regulation limits to PWOK asserted at turn on.	100	1000	msec
T _{pwok_off}	Delay from PWOK de-asserted to output voltages (3.3V, 5V, 12V, -12V) dropping out of regulation limits.	1		msec

Item	Description	Minimum	Maximum	Units
T _{pwok_low}	Duration of PWOK being in the de-asserted state during an off/on cycle using AC or the PSON signal.	100		msec
T _{sb_vout}	Delay from 5VSB being in regulation to O/Ps being in regulation at AC turn on.	50	1000	msec
T _{5VSB_holdup}	Time the 5VSB output voltage stays within regulation after loss of AC.	70		msec

2.2.5.11 Residual Voltage Immunity in Standby Mode

The power supply is immune to any residual voltage placed on its outputs (Typically a leakage voltage through the system from standby output) up to 500mV. There is neither additional heat generated, nor stress of any internal components with this voltage applied to any individual output, and all outputs simultaneously. It also does not trip the protection circuits during turn on.

The residual voltage at the power supply outputs for no load condition does not exceed 100mV when AC voltage is applied.

2.2.6 Protection Circuits

Protection circuits inside the power supply cause only the power supply's main outputs to shutdown. If the power supply latches off due to a protection circuit tripping, an AC cycle OFF for 15sec and a PSON# cycle HIGH for 1sec will reset the power supply.

2.2.6.1 Over-Current Protection (OCP)

The power supply has a current limit to prevent the +3.3V, +5V, and +12V outputs from exceeding 240VA. If the current limits are exceeded the power supply will shutdown and latch off. The latch will be cleared by toggling the PSON# signal or by an AC power interruption. The power supply will not be damaged from repeated power cycling in this condition. -12V and 5VSB are protected under over current or shorted conditions so that no damage can occur to the power supply. Auto-recovery feature exists on the 5VSB rail.

2.2.6.2 Over Voltage Protection (OVP)

The power supply over voltage protection is locally sensed. The power supply will shutdown and latch off after an over voltage condition occurs. This latch can be cleared by toggling the PSON# signal or by an AC power interruption. The following table contains the over voltage limits. The values are measured at the output of the power supply's connectors. The voltage never exceeds the maximum levels when measured at the power pins of the power supply connector during any single point of fail. The voltage will not trip any lower than the minimum levels when measured at the power pins of the power supply connector.

Exception: +5VSB rail will recover after its over voltage condition occurs.

Table 38. Over Voltage Protection Limits

Output Voltage	MIN (V)	MAX (V)
+3.3V	3.71	4.2
+5V	5.62	6.5
+12V1,2	13.4	15.0
-12V	-13.5	-15.0
+5VSB	5.7	6.5

2.2.6.3 Over Temperature Protection (OTP)

The power supply is protected against over temperature conditions caused by loss of fan cooling or excessive ambient temperature. In an OTP condition the PSU will shutdown. When the power supply temperature drops to within specified limits, the power supply will restore power automatically, while the 5VSB remains always on. The OTP circuit has a built in hysteresis such that the power supply will not oscillate on and off due to a temperature recovering condition. The OTP trip level has a minimum of 4°C of ambient temperature hysteresis.

2.2.6.4 PSON# Input Signal

The PSON# signal is required to remotely turn on/off the power supply. PSON# is an active low signal that turns on the +3.3V, +5V, +12V, and -12V power rails. When this signal is not pulled low by the system, or left open, the outputs (except the +5VSB) turn off. This signal is pulled to a standby voltage by a pull-up resistor internal to the power supply.

Table 39. PSON# Signal Characteristic

Signal Type	Accepts an open collector/drain input from the system. Pull-up to 5V located in power supply.	
PSON# = Low	ON	
PSON# = High or Open	OFF	
	MIN	MAX
Logic level low (power supply ON)	0V	1.0V
Logic level high (power supply OFF)	2.0V	5.25V
Source current, Vpson = low		4mA
Power up delay: $T_{pson_on_delay}$	5msec	400msec
PWOK delay: T_{pson_pwok}		50msec

2.2.6.5 PWOK (Power OK) Output Signal

PWOK is a power OK signal and is pulled HIGH by the power supply to indicate that all the outputs are within the regulation limits of the power supply. When any output voltage falls below regulation limits or when AC power has been removed for a time sufficiently long so that power supply operation is no longer guaranteed, PWOK will be de-asserted to a LOW state. The start of the PWOK delay time is inhibited as long as any power supply output is in current limit.

Table 40. PWOK Signal Characteristics

Signal Type	Open collector/drain output from power supply. Pull-up to VSB located in system.	
PWOK = High	Power OK	
PWOK = Low	Power Not OK	
	MIN	MAX
Logic level low voltage, Isink=4mA	0V	0.4V
Logic level high voltage, Isource=200μA	2.4V	5.25V
Sink current, PWOK = low		4mA
Source current, PWOK = high		2mA

PWOK delay: T_{pwok_on}	100ms	1000ms
PWOK rise and fall time		100 μ sec
Power down delay: T_{pwok_off}	1ms	200msec

2.3 500-Watt Power Supply

The 500-W power supply specification defines a redundant power supply and power distribution cage that supports a DP Intel® Xeon™ server system. The power supply shall have 2 outputs to power the system: 12V and 5VSB. The AC input shall be auto ranging and power factor corrected.

2.3.1 Mechanical Overview

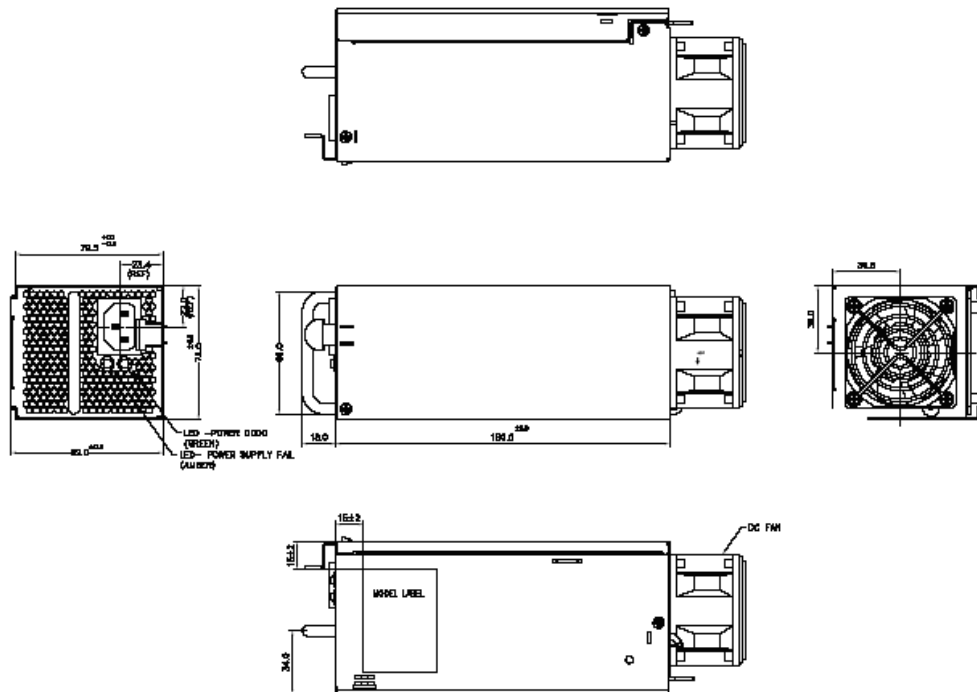

Figure 12. Mechanical Drawing for Dual (1+1 Configuration) Power Supply Enclosure with Power Distribution Board

2.3.2 Handle and Retention Mechanism

The power supply has a handle to assist in insertion and extraction. The module can be inserted and extracted without the assistance of tools. The power supply has a retention mechanism, which retains the power supply into the system or enclosure during all mechanical shock (50G) and vibration testing. The handle protects the operator from any burn hazard through the use of the Intel Corporation Industrial designed plastic handle. The plastic handle is molded in the following material:

<u>Material</u>	<u>Color</u>	<u>Designation</u>
GE 2800	Green	GN3058
BAYER FR2000	Green	3200

2.3.3 Hot Swap Support

Hot swapping a power supply is the process of inserting and extracting a power supply from an operating power system. During this process the output voltages remain within the limits with the capacitive load specified. The power supply can be hot swapped by the following method:

- Extraction: The power supply may be removed from the system while operating with PSON# asserted, while in standby mode with PSON# de-asserted, or with no AC applied. No connector damage will occur due to the un-mating of the power supply from the power distribution board.
- Insertion: The power supply may be inserted into the system with PSON# asserted, with PSON# de-asserted, or with no AC power present for that supply. No connector damage will occur during mating of the output and input connector power.

In general, a failed (off by internal latch or external control) power supply may be removed, then replaced with a good power supply; however, hot swap will work with both operational as well as failed power supplies. The newly inserted power supply will get turned on into standby or Power On mode once inserted.

2.3.4 Airflow and Temperature

The power supply operates within all specified limits over the operating conditions described in the below table. All airflow passes through the power supply and not over the exterior surfaces of the power supply.

The power supply meets UL enclosure requirements for temperature rise limits. All sides of the power supply with exception to the air exhaust side, are classified as “Handle, knobs, grips, etc. held for short periods of time only”.

Table 41. Environmental Requirements

Item	Description	MIN	Specification	Units
T _{op}	Operating temperature range.	0	45	°C
T _{non-op}	Non-operating temperature range.	-40	70	°C

Item	Description	MIN	Specification	Units
Altitude	Maximum operating altitude		1500	m

2.3.5 Output Cable Harness

The output wiring harness is part of the power distribution board (backplane) and is described in that section.

2.3.6 AC Input Requirements

The power supply operates within all specified limits over the following input voltage range, shown in below table. Harmonic distortion of up to 10% THD must not cause the power supply to go out of specified limits. The power supply does power off if the AC input is less than 75VAC +/-5VAC range. The power supply starts up if the AC input is greater than 85VAC +/-4VAC. Application of an input voltage below 85VAC does not cause damage to the power supply, including a fuse blow.

Table 42. AC Input Rating

Parameter	MIN	Rated	MAX	Start up VAC	Power Off VAC	Max Input Current	Max Rated Input AC Current
Voltage (110)	90 V _{rms}	100-127 V _{rms}	140 V _{rms}	85Vac +/- 4Vac	75Vac +/- 5Vac	7.7 A _{rms} ^{1,3}	6.7 A _{rms} ⁴
Voltage (220)	180 V _{rms}	200-240 V _{rms}	264 V _{rms}			4.3 A _{rms} ^{2,3}	3.35 A _{rms} ⁴
Frequency	47 Hz	50/60Hz	63 Hz				

1 Maximum input current at low input voltage range shall be measured at 90Vac, at max load.

2 Maximum input current at high input voltage range shall be measured at 180VAC, at max load.

3 This is not to be used for determining agency input current markings.

4 Maximum rated input current is measured at 100VAC and 200VAC.

2.3.6.1 AC Inlet Connector

Each module has an IEC 320 C-14 power inlet. This inlet is rated for 15A / 250VAC.

2.3.6.2 Efficiency

The following table provides the required minimum efficiency level for the power supply module. Efficiency shall be tested over an AC input voltage range of 90VAC to 264VAC.

Table 43. Efficiency

Power Supply Version	100% of Maximum
500W	> 75%

2.3.6.3 AC Line Dropout / Holdup

Below are the AC dropout requirements.

Table 44. Holdup Requirements

Loading	Holdup time
100%	12msec
60%	20msec

An AC line **dropout** is defined to be when the AC input drops to 0VAC at any phase of the AC line for any length of time. During an AC dropout condition, either 1+0 or 1+1, power supply configuration meets dynamic voltage regulation requirements. An AC line dropout of any duration will not cause tripping of control signals or protection circuits. If the AC dropout lasts longer than the hold up time the power supply will recover and meet all turn on requirements. The power supply meets the AC dropout requirement over rated AC voltages and frequencies. A dropout of the AC line for any duration will not cause damage to the power supply.

2.3.6.3.1 AC Line 5VSB Holdup

The 5VSB output voltage stays in regulation under its full load (static or dynamic) during an AC dropout of **70ms** min (=5VSB holdup time) whether the power supply is in ON or OFF state (PSON asserted or de-asserted).

2.3.6.4 AC Line Fuse

The power supply has a **single line fuse** on the line (hot) wire of the AC input. The line fusing is acceptable for all safety agency requirements. The input fuse is a slow blow type. AC inrush current will not cause the AC line fuse to blow under any conditions. All protection circuits in the power supply will not cause the AC fuse to blow unless a component in the power supply has failed. This includes DC output load short conditions.

2.3.6.5 AC Inrush

AC line inrush current will not exceed **55A peak** for up to one-quarter of the AC cycle, after which, the input current is no more than the specified maximum input current. The peak inrush current is less than the ratings of its critical components (including input fuse, bulk rectifiers, and surge limiting device).

The power supply meets the inrush requirements for any rated AC voltage, during turn on at any phase of AC voltage, during a single cycle AC dropout condition as well as upon recovery after AC dropout of any duration, and over the specified temperature range (T_{op}).

2.3.6.6 AC Line Transient Specification

AC line transient conditions are defined as “sag” and “surge” conditions. “Sag” conditions are also commonly referred to as “brownout,” these conditions will be defined as the AC line voltage dropping below nominal voltage conditions. “Surge” will be defined to refer to conditions when

the AC line voltage rises above nominal voltage. The power supply meets the requirements under the following AC line sag and surge conditions.

Table 45. AC Line Sag Transient Performance

Duration	Sag	Operating AC Voltage	Line Frequency	Performance Criteria
Continuous	10%	Nominal AC Voltage ranges	50/60Hz	No loss of function or performance
0 to 1 AC cycle	100 %	Nominal AC Voltage ranges	50/60Hz	No loss of function or performance
> 1 AC cycle	>10 %	Nominal AC Voltage ranges	50/60Hz	Loss of function acceptable, self recoverable

Table 46. AC Line Surge Transient Performance

Duration	Surge	Operating AC Voltage	Line Frequency	Performance Criteria
Continuous	10%	Nominal AC Voltages	50/60Hz	No loss of function or performance
0 to ½ AC cycle	30%	Mid-point of nominal AC Voltages	50/60Hz	No loss of function or performance

2.3.6.7 AC Line Fast Transient (EFT) Specification

The power supply meets the *EN61000-4-5* directive and any additional requirements in *IEC1000-4-5: 1995* and the Level 3 requirements for surge-withstand capability, with the following conditions and exceptions:

- These input transients do not cause any out-of-regulation conditions, such as overshoot and undershoot, nor must it cause any nuisance trips of any of the power supply protection circuits.
- The supply meets surge-withstand conditions under maximum and minimum DC-output load conditions.

2.3.6.8 AC Line Leakage Current

The maximum leakage current to ground for each power supply is 3.5mA when tested at 240VAC.

2.3.7 DC Output Specification

2.3.7.1 Power Supply Mating Connector

The power supply module shall use the card edge for output power to the power distribution board and AC input power to the module.

Table 47. Power Supply Edge Connector Slot Pin-out (location)

Pin	Signal Name	Pin	Signal Name
1	+12V	25	+12V Return
2	+12V	26	+12V Return
3	+12V	27	+12V Return
4	+12V	28	+12V Return
5	+12V	29	+12V Return
6	+12V	30	+12V Return
7	+12V	31	+12V Return
8	+12V	32	+12V Return
9	+12V	33	+12V Return
10	+12V	34	+12V Return
11	+12V	35	+12V Return
12	+12V	36	+12V Return
13	+12V	37	5VSB
14	+12V	38	Aux Return
15	+12V	39	SDA
16	+12V	40	+12V Sharing
17	+12V	41	PS_KILL
18	+12V	42	POK
19	+12V Return	43	PS_ON_CTL
20	+12V Return	44	-PS Present
21	+12V Return	45	FAN_TACH
22	+12V Return	46	A1
23	+12V Return	47	SCL
24	+12V Return	48	-OVER_TEMP

2.3.7.2 Standby Output

The 5VSB output is present when an AC input greater than the power supply turn-on voltage is applied.

2.3.7.3 Power Module Output Power / Currents

Power requirements for the power supply module are defined in the following table.

Table 48. Power Supply Module Load Ratings

Voltage	540-W		
	Min	Max	Peak
+12 V	2.0 A	41 A	49.A
+5 VSB	0.1 A	2.0 A	2.5 A

Peak power and current loading shall be supported for a minimum of 12 seconds.

2.3.7.4 Voltage Regulation

The power supply output voltages at the end of the power distribution board wire harness must stay within the following voltage limits when operating at steady state and dynamic loading conditions. These limits include the peak-peak ripple/noise. All outputs are measured with reference to the return remote sense signal (ReturnS). The 12V and 5VSB outputs are measured at the power supply connectors referenced to ReturnS.

Table 49. Voltage Regulation Limits

Parameter	Tolerance	MIN	NOM	MAX	Units
+ 12V1,2,3,4	- 5% / +5%	+11.40	+12.00	+12.60	V _{rms}
+ 5VSB	- 5% / +5%	+4.75	+5.00	+5.25	V _{rms}

2.3.7.5 Dynamic Loading

The output voltages remain within limits specified for the step loading and capacitive loading specified in the following table. The Δ step load may occur anywhere within the MIN load to the MAX load conditions.

Table 50. Transient Load Requirements

Output	Δ Step Load Size	Load Slew Rate	Test Capacitive Load
12V	60% of max load	0.25 A/ μ sec	2200 μ F ¹
+5VSB	0.5A	0.25 A/ μ sec	20 μ F

Note:

1. Step loads on each 12V output may happen **simultaneously**.

2.3.7.6 DC/DC Converter Capacitive Loading

The power supply shall be stable and meet all requirements with the following capacitive loading ranges.

Table 51. Capacitive Loading Conditions

Output	MIN	MAX	Units
+12V1,2,3,4	500 each	11,000	μ F
+5VSB	20	350	μ F

2.3.7.7 DC/DC Converters Closed Loop Stability

The power supply is stable under all line/load/transient load conditions including, capacitive load ranges. A minimum of: **45 degrees phase margin** and **-10dB-gain margin** is met. Closed-loop stability is ensured at the maximum and minimum loads as applicable.

2.3.7.8 Common Mode Noise

The Common Mode noise on any output does not exceed **350mV pk-pk** over the frequency band of 10Hz to 30MHz.

2.3.7.9 Ripple / Noise

The maximum ripple/noise output of the power supply is defined in the following table. This is measured over a bandwidth of 0Hz to 20MHz at the power supply output connectors. A 10 μ F tantalum capacitor in parallel with a 0.1 μ F ceramic capacitor is placed at the point of measurement.

Table 52. Ripple and Noise

+12V	+5VSB
120mVp-p	50mVp-p

2.3.7.10 Timing Requirements

The timing requirements for power supply operation are as follows. The output voltages must rise from 10% to within regulation limits (T_{vout_rise}) within 5 to 70ms, except for 5VSB - it is allowed to rise from 1.0 to 25ms. **All outputs rise monotonically.** Each output voltage shall reach regulation within 50ms (T_{vout_on}) of each other during turn on of the power supply. Each output voltage shall fall out of regulation within 400msec (T_{vout_off}) of each other during turn off. The following figure shows the timing requirements for the power supply being turned on and off via the AC input, with PSON held low and the PSON signal, with the AC input applied.

Table 53. Output Voltage Timing

Item	Description	Minimum	Maximum	Units
T_{vout_rise}	Output voltage rise time from each main output.	5.0 *	70 *	msec
T_{vout_on}	All main outputs must be within regulation of each other within this time.		50	msec
T_{vout_off}	All main outputs must leave regulation within this time.		400	msec

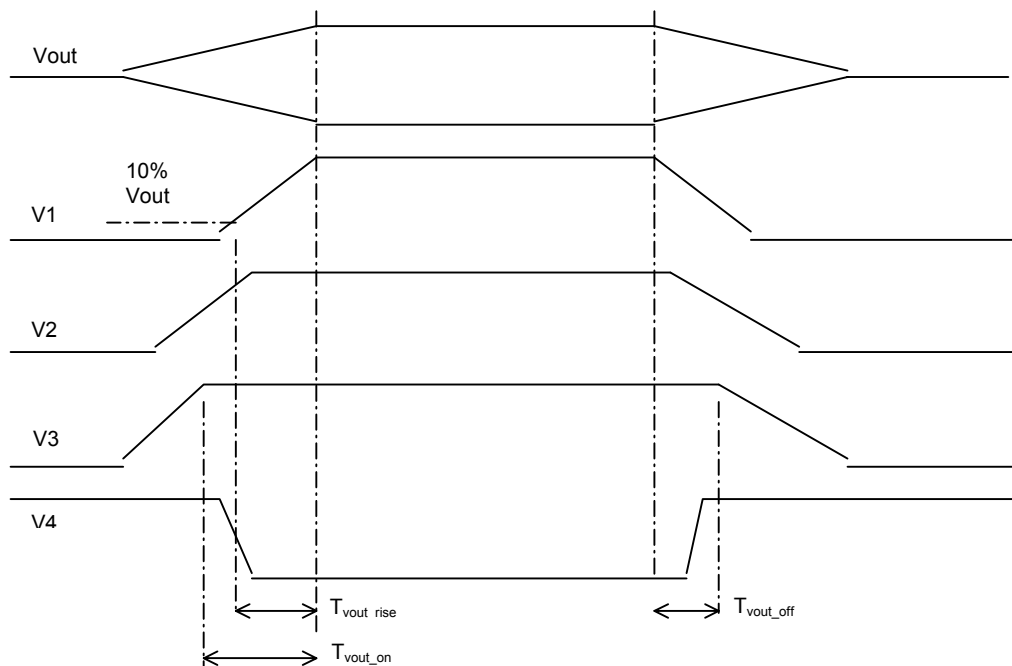

Figure 13. Output Voltage Timing

Table 54. Turn On / Off Timing

Item	Description	Minimum	Maximum	Units
T _{sb_on_delay}	Delay from AC being applied to 5VSB being within regulation.		1000	msec
T _{ac_on_delay}	Delay from AC being applied to all output voltages being within regulation.		2500	msec
T _{vout_holdup}	Time all output voltages stay within regulation after loss of AC.	21		msec
T _{pwok_holdup}	Delay from loss of AC to de-assertion of PWOK	20		msec
T _{pson_on_delay}	Delay from PSON [#] active to output voltages within regulation limits.	5	400	msec
T _{pson_pwok}	Delay from PSON [#] deactive to PWOK being de-asserted.		50	msec
T _{pwok_on}	Delay from output voltages within regulation limits to PWOK asserted at turn on.	100	1000	msec
T _{pwok_off}	Delay from PWOK de-asserted to output voltages (3.3V, 5V, 12V, -12V) dropping out of regulation limits.	1		msec
T _{pwok_low}	Duration of PWOK being in the de-asserted state during an off/on cycle using AC or the PSON signal.	100		msec
T _{sb_vout}	Delay from 5VSB being in regulation to O/Ps being in regulation at AC turn on.	50	1000	msec
T _{5VSB_holdup}	Time the 5VSB output voltage stays within regulation after loss of AC.	70		msec

2.3.7.11 Residual Voltage Immunity in Standby Mode

The power supply is immune to any residual voltage placed on its outputs (typically a leakage voltage through the system from standby output) up to 500mV. There is neither additional heat generated, nor stress of any internal components with this voltage applied to any individual output, and all outputs simultaneously. It also will not trip the power supply protection circuits during turn on.

2.3.8 Protection Circuits

Protection circuits inside the power supply cause only the power supply's main outputs to shutdown. If the power supply latches off due to a protection circuit tripping, an AC cycle OFF for 15sec and a PSON[#] cycle HIGH for 1sec will reset the power supply.

2.3.8.1 Over-Current Protection (OCP)

The power supply has a current limit to prevent the +3.3V, +5V, and +12V outputs from exceeding the values shown in the following figure. If the current limits are exceeded the power supply will shutdown and latch off. The latch will be cleared by toggling the PSON# signal or by an AC power interruption. The power supply is not damaged from repeated power cycling in this condition. 5VSB is protected under over current or shorted conditions so that no damage can occur to the power supply. Auto-recovery feature is a requirement on the 5VSB rail.

Table 55. Over Current Protection (OCP)

Voltage	Over Current Limit (Iout Limit)
12V	49.2 A min; 57.4 A max
5VSB	3.0 A min; 4.0 A max

2.3.8.2 Over Voltage Protection (OVP)

The power supply over voltage protection is locally sensed. The power supply will shutdown and latch off after an over voltage condition occurs. This latch can be cleared by toggling the PSON# signal or by an AC power interruption. The following table contains the over voltage limits. The values are measured at the output of the power supply's connectors. The voltage never exceeds the maximum levels when measured at the power pins of the power supply connector during any single point of fail. The voltage will not trip any lower than the minimum levels when measured at the power pins of the power supply connector.

Exception: The +5VSB rail will recover after its over voltage condition occurs.

Table 56. Over Voltage Protection Limits

Output Voltage	MIN (V)	MAX (V)
+12V1,2,	13.3	14.5
+5VSB	5.7	6.5

2.3.8.3 Over Temperature Protection (OTP)

The power supply is protected against over temperature conditions caused by loss of fan cooling or excessive ambient temperature. In an OTP condition the power supply unit will shutdown.

2.3.8.4 PSON# Input Signal

The PSON# signal is required to remotely turn on/off the power supply. PSON# is an active low signal that turns on the +3.3V, +5V, +12V, and -12V power rails. When this signal is not pulled

low by the system, or left open, the outputs (except for the +5VSB) turn off. This signal is pulled to a standby voltage by a pull-up resistor internal to the power supply.

Table 57. PSON[#] Signal Characteristic

Signal Type	Accepts an open collector/drain input from the system. Pull-up to VSB located in power supply.	
PSON [#] = Low	ON	
PSON [#] = High or Open	OFF	
	MIN	MAX
Logic level low (power supply ON)	0V	1.0V
Logic level high (power supply OFF)	2.0V	5.25V
Source current, Vpson = low		4mA
Power up delay: T _{pson_on_delay}	5msec	400msec
PWOK delay: T _{pson_pwok}		50msec

2.3.8.5 PSKill

The purpose of the PSKill pin is to allow for hot swapping of the power supply. The PSKill pin on the power supply is shorter than the other signal pins. When a power supply is operating in parallel with other power supplies and then extracted from the system, the PSKill pin will quickly turn off the power supply and prevent arcing of the DC output contacts.

Table 58. PSKILL Signal Characteristics

Signal Type (Input Signal to Supply)	Accepts a ground input from the system. Pull-up to VSB located in the power supply.	
PSKILL = Low, PSON [#] = Low	ON	
PSKILL = Open, PSON [#] = Low or Open	OFF	
PSKILL = Low, PSON [#] = Open	OFF	
	MIN	MAX
Logic level low (power supply ON)	0V	1.0V
Logic level high (power supply OFF)	2.0V	5.25V
Source current, Vpskill = low		4mA

Delay from PSKILL=High to power supply turned off (T_{PSkill}) ¹		100 μ sec
---	--	---------------

1 T_{PSkill} is the time from the PSkill signal de-asserting HIGH to the power supply's output inductor discharging.

2.3.8.6 PWOK (Power OK) Output Signal

PWOK is a power OK signal and is pulled HIGH by the power supply to indicate that all the outputs are within the regulation limits of the power supply. When any output voltage falls below regulation limits or when AC power has been removed for a time sufficiently long so that power supply operation is no longer guaranteed, PWOK will be de-asserted to a LOW state. The start of the PWOK delay time is inhibited as long as any power supply output is in current limit.

Table 59. PWOK Signal Characteristics

Signal Type	Open collector/drain output from power supply. Pull-up to VSB located in system.	
PWOK = High	Power OK	
PWOK = Low	Power Not OK	
	MIN	MAX
Logic level low voltage, $I_{sink}=4mA$	0V	0.4V
Logic level high voltage, $I_{source}=200\mu A$	2.4V	5.25V
Sink current, PWOK = low		4mA
Source current, PWOK = high		2mA
PWOK delay: T_{pwok_on}	100ms	1000ms
PWOK rise and fall time		100 μ sec
Power down delay: T_{pwok_off}	1ms	200msec

2.3.8.7 LED Signal

There is a single bi-color LED to indicate power supply status. The LED operation is defined in the following table.

Table 60. LED Indicators

Power Supply Condition	AC OK / Power Supply Fail LED	Power Good LED
No AC power to all power supplies	OFF	OFF
Power supply critical event causing a shutdown; failure, fuse blown (1+1 only) OCP, OVP, Fan Fail	AMBER	OFF
Power supply warning events where the power supply continues to operate; high temp, high power, high current, slow fan.	GREEN	OFF
AC present / Only 5VSB on (PS off)	GREEN	OFF
Output ON and OK	GREEN	GREEN
OTP	AMBER	GREEN

The LED is visible on the power supply's exterior face. The LED's location also meets ESD requirements. There are bits that allow the LED state to be forced via SMBus. The following capabilities are required:

- Force Amber ON for **failure conditions**.
- Force Amber 1Hz Blink **for warning conditions**.
- No Force (**LED state follows power supply present state**)

The power-on default is '**No Force**'. The default is restored whenever PSON transitions to assert.

2.3.9 SMBus Monitoring Interface

The power supply and cage provides a monitoring interface to the system over a server management bus to the system. The device is compatible with both SMBus 2.0 'high power' and I²C V_{dd} based power and drive. This bus operates at 5V. The SMBus pull-ups are located on the motherboard.

The SMBus shall provide IPMI FRU data and failure status. Two pins have been reserved on the connector to provide this information. One pin is the Serial Clock (PSM Clock). The second pin is used for Serial Data (PSM Data). Both pins are bi-directional and are used to form a serial bus. The circuits inside the power supply shall be powered from the 5VSB bus and grounded to ReturnS (remote sense return). The EEPROM for FRU data in the power supply is hard wired to allow writing data to the device.

2.4 500-Watt Power Distribution Board

This specification defines the cage for the ERP 12V 500W 1+1 redundant power supply. The cage is designed to plug directly to the output connector of the power supplies and contains three DC/DC power converters to produce other required voltages: +3.3VDC, +5VDC and –

12VDC along with additional 12V rail 240VA protection and fan control circuitry and a FRU EEPROM.

2.4.1 Mechanical Overview

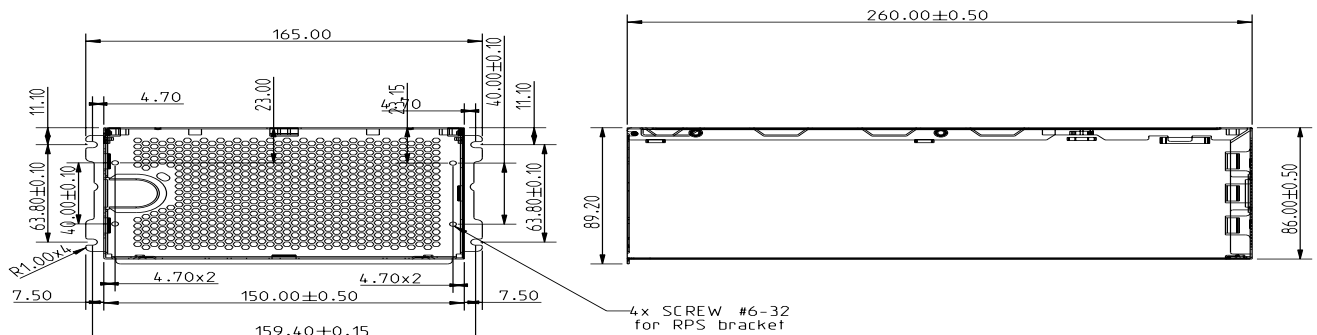

Figure 14. Mechanical Drawing for Dual (1+1 Configuration) Power Supply Enclosure with Power Distribution Board

2.4.2 Airflow and Temperature Requirements

The power supply shall operate within all specified limits over the operating conditions described in the below table. All airflow shall pass through the power supply and not over the exterior surfaces of the power supply.

The power supply must meet UL enclosure requirements for temperature rise limits. All sides of the power supply, with exception of the air exhaust side, must be classified as “Handle, knobs, grips, etc. held for short periods of time only.”

Table 61. Environmental Requirements

Item	Description	MIN	Specification	Units
T _{op}	Operating temperature range.	0	45	°C
T _{non-op}	Non-operating temperature range.	-40	70	°C
Altitude	Maximum operating altitude		1500	m

2.4.3 Electrical Specification

2.4.3.1 Input Connector (Power Supply Mating Connector)

Table 62. Edge Finger Power Supply Connector Pin-out

Pin	Signal Name	Pin	Signal Name
1	+12V	25	+12V Return
2	+12V	26	+12V Return
3	+12V	27	+12V Return
4	+12V	28	+12V Return
5	+12V	29	+12V Return
6	+12V	30	+12V Return
7	+12V	31	+12V Return
8	+12V	32	+12V Return
9	+12V	33	+12V Return
10	+12V	34	+12V Return
11	+12V	35	+12V Return
12	+12V	36	+12V Return
13	+12V	37	5VSB
14	+12V	38	Aux Return
15	+12V	39	SDA
16	+12V	40	+12V Sharing
17	+12V	41	PS_KILL
18	+12V	42	POK

Pin	Signal Name	Pin	Signal Name
19	+12V Return	43	PS_ON_CTL
20	+12V Return	44	-PS Present
21	+12V Return	45	FAN_TACH
22	+12V Return	46	A1
23	+12V Return	47	SCL
24	+12V Return	48	-OVER_TEMP

2.4.3.2 Output Cable Harness

The power distribution board has a wire harness output with the following connectors.

Wiring material (AVLV2), CN, **rated min 105°C**, 300VDC is used for all output wiring.

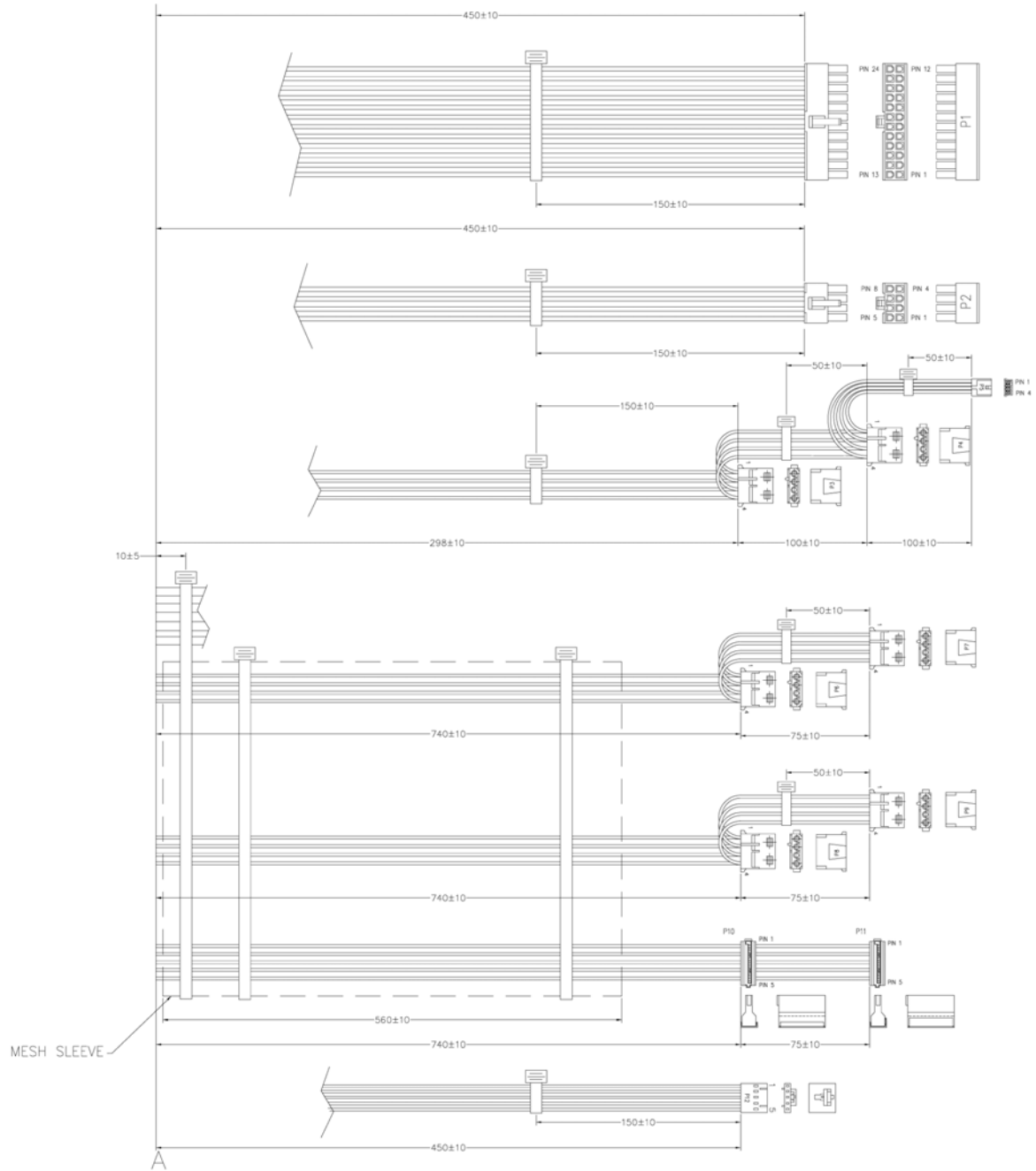

Figure 15. Output Cable Harness for 500-W Power Supply

Table 63. Cable Lengths

From	Length (mm)	To connector #	No of pins	Description
Power Supply cover exit hole	450	P1	24	Baseboard Power Connector
Power Supply cover exit hole	450	P2	8	Processor Power Connector
Power Supply cover exit hole	298	P3	4	Peripheral Power Connector
Extension	100	P4	4	Peripheral Power Connector
Extension from P4	100	P5	4	Floppy Power Connector
Power Supply cover exit hole	740	P6	4	Peripheral Power Connector
Extension from P6	75	P7	4	Peripheral Power Connector
Power Supply cover exit hole	740	P8	4	Peripheral Power Connector
Extension	75	P9	4	Peripheral Power Connector
Power Supply cover exit hole	740	P10	4	Peripheral Power Connector
Extension	75	P11	4	Peripheral Power Connector
Power Supply cover exit hole	740	P12	5	Right-angle SATA Power Connector

2.4.3.3 Baseboard Power Connector (P1)

Connector housing: 24-Pin Molex Mini-Fit Jr. 39-01-2245 or equivalent
 Contact: Molex Mini-Fit, **HCS**, Female, Crimp 44476 or equivalent

Table 64. P1 Baseboard Power Connector

Pin	Signal	18 AWG Color	Pin	Signal	18 AWG Color
1*	+3.3VDC	Orange	13	+3.3VDC	Orange
	3.3V RS	Orange (24AWG)	14	-12VDC	Blue
2	+3.3VDC	Orange	15	COM	Black

Pin	Signal	18 AWG Color	Pin	Signal	18 AWG Color
3*	COM	Black	16	PSO#	Green (24AWG)
	COM RS	Black (24AWG)	17	COM	Black
4*	+5VDC	Red	18	COM	Black
	5V RS	Red (24AWG)	19	COM	Black
5	COM	Black	20	Reserved	N.C.
6	+5VDC	Red	21	+5VDC	Red
7	COM	Black	22	+5VDC	Red
8	PWR OK	Gray (24AWG)	23	+5VDC	Red
9	5 VSB	Purple	24	COM	Black
10	+12V3	Yellow			
11	+12V3	Yellow			
12	+3.3VDC	Orange			

Note: Remote Sense wire double crimped.

2.4.3.4 Processor Power Connector (P2)

Connector housing: 8-Pin Molex 39-01-2080 or equivalent

Contact: Molex 44476-1111 or equivalent

Table 65. P2 Processor Power Connector

Pin	Signal	18 AWG Color	Pin	Signal	18 AWG Color
1	COM	Black	5*	+12V1	White
2	COM	Black	6	+12V1	White
3	COM	Black	7	+12V2	Brown
4	COM	Black	8	+12V2	Brown

2.4.3.5 Power Signal Connector (P14)

Connector housing: 5-pin Molex 50-57-9405 or equivalent

Contacts: Molex 16-02-0087 or equivalent

Table 66. Power Signal Connector

Pin	Signal	24 AWG Color
1	I2C Clock	White
2	I2C Data	Yellow
3	Reserved	N.C.
4	COM	Black
5	3.3RS	Orange

2.4.3.6 Peripheral Power Connectors (P3, P4, P8, P9, P10, P11)

Connector housing: Amp 1-480424-0 or equivalent

Contact: Amp 61314-1 contact or equivalent

Table 67. Peripheral Power Connectors

Pin	Signal	18 AWG Color
1	+12V4	Green
2	COM	Black
3	COM	Black
4	+5 VDC	Red

2.4.3.7 Floppy Power Connector (P5)

Connector housing: Amp 171822-4 or equivalent

Contact: Amp 170204-1 contact or equivalent

Table 68. Floppy Power Connector

Pin	Signal	22 AWG Color
1	+5VDC	Red
2	COM	Black
3	COM	Black
4	+12V4	Green

2.4.3.8 Right-Angle SATA Power Connector (P12)

Connector housing: JWT F6002HS0-5P-18 or equivalent

Table 69. SATA Power Connector

Pin	Signal	18 AWG Color
1	+3.3V	Orange
2	COM	Black
3	+5VDC	Red
4	COM	Black
5	+12V4	Green

2.4.3.9 SATA Power Connector (P13)

Connector housing: JWT A3811H00-5P or equivalent

Contact: JWT A3811TOP-0D or equivalent

Table 70. SATA Power Connector

Pin	Signal	18 AWG Color
1	+3.3V	Orange
2	COM	Black
3	+5VDC	Red
4	COM	Black
5	+12V4	Green

2.4.4 Efficiency

Each DC/DC converter shall have a **minimum** efficiency of **85%** at Max load and over +12V line voltage range and over temperature and humidity range.

2.4.5 Grounding

The ground of the pins of the cage output connectors provides the power return path. The output connector ground pins is connected to safety ground (cage enclosure). A mounting hole on the cage is also safety grounded to the system enclosure with a screw plus lock washer.

2.4.6 Remote Sense

The power supply has remote sense return (ReturnS) to regulate out ground drops for all output voltages; +3.3V, +5V, +12V1, +12V2, +12V3, +12V4, -12V, and 5VSB. The power supply uses remote sense (3.3VS) to regulate out drops in the system for the +3.3V output. The +5V, +12V1, +12V2, +12V3, +12V4, -12V and 5VSB outputs only use remote sense referenced to the ReturnS signal. The remote sense input impedance to the power supply is greater than 200Ω on 3.3VS, 5VS. This is the value of the resistor connecting the remote sense to the output voltage internal to the power supply. Remote sense is able to regulate out a minimum of 200mV drop on the +3.3V output. The remote sense return (ReturnS) is able to regulate out a minimum of 200mV drop in the power ground return. The current in any remote sense line is less than 5mA to prevent voltage sensing errors. The power supply operates within specification over the full range of voltage drops from the power supply's output connector to the remote sense points.

2.4.7 Outputs Load Requirements

The requirements for the combined power supply module and power distribution board are as follows.

Table 71. Cage Load Ratings

Voltage	Min	Max	Peak
+3.3 V	0.5 A	24 A	
+5 V	0.5 A	24 A	
+12 V1	0.5 A	15 A	17 A
+12 V2	0.5 A	15 A	17 A
+12 V3	0.5 A	15 A	17 A
+12 V4	0.5 A	15 ^a	17A
-12 V	0 A	0.3 A	
+5 VSB	0.1 A	2.0 A	2.5 A

1. Maximum continuous total DC output power should not exceed 500 W.
2. Peak power and current loading shall be supported for a minimum of 12 seconds.
3. Combined 3.3V and 5V power shall not exceed 140 W.
4. 12V1, 2, 3, 4 rails has separate 240VA protection circuits.

2.4.8 DC/DC Converters Voltage Regulation

The DC/DC converters' output voltages stay within the following voltage limits when operating at **steady state and dynamic loading conditions**. These limits include the peak-peak ripple/noise. All outputs are measured with reference to the return remote sense signal (ReturnS). The 3.3V and 5V outputs are measured at the remote sense point, all other voltages measured at the output harness connectors.

Table 72. Voltage Regulation Limits

PARAMETER	TOLERANCE	MIN	NOM	MAX	UNITS
+ 3.3V	- 5% / +5%	+3.14	+3.30	+3.46	V _{rms}
+ 5V	- 5% / +5%	+4.75	+5.00	+5.25	V _{rms}
+ 12V1,2,3,4	- 5% / +5%	+11.40	+12.00	+12.60	V _{rms}
- 12V	- 5% / +9%	-11.40	-12.00	-13.08	V _{rms}
+ 5VSB	- 5% / +5%	+4.75	+5.00	+5.25	V _{rms}

2.4.9 DC / DC Converters Dynamic Loading

The output voltages remain within limits specified for the step loading and capacitive loading specified in the following table. The Δ step load may occur anywhere within the MIN load to the MAX load conditions.

Table 73. Transient Load Requirements

Output	Max Δ Step Load Size	Max Load Slew Rate	Test capacitive Load
+ 3.3VDC	5.0A (note 1)	0.25 A/ μ s	250 μ F
+ 5VDC	4.0A (note 1)	0.25 A/ μ s	400 μ F
+12VDC (12V1/2/3/4/5)	See the Power Supply specification for details		
- 12VDC	<i>Not rated</i>	<i>Not rated</i>	μ F
+5Vsb	See the Power Supply spec for details		

2.4.10 DC / DC Converter Capacitive Loading

All outputs of the DC / DC converter meet all requirements with the following capacitive loading ranges.

Table 74. Capacitive Loading Conditions

Converter Output	MIN	MAX	Units
+3.3VDC	250	6,800	μF
+5VDC	400	4,700	μF
-12VDC	1	350	μF

Note: Refer to the Power Supply specification for the equivalent data on +12V and +5VSB output.

2.4.11 DC/DC Converters Ripple / Noise

The maximum allowed ripple/noise output of each DC/DC Converter is defined in the following table. This is measured over a bandwidth of 0Hz to 20MHz at the PDB output connectors. A 10μF tantalum capacitor in parallel with a 0.1μF ceramic capacitor is placed at the point of measurement.

Table 75. Ripple and Noise

+3.3V Output	+5V Output	-12V Output
50mVp-p	50mVp-p	120mVp-p

Note: Refer to the Power Supply specification for the equivalent data on +12V and +5VSB output.

2.4.12 Protection Circuits

Protection circuits inside the cage (and the power supply) cause either the power supply's main +12V output to shutdown, which in turn shuts down the other three outputs on the cage or first shut down any of the 3 outputs on the cage, which in turn also shuts down the entire power supply combo. If the power supply latches off due to a protection circuit tripping, an AC cycle OFF for 15 sec min and a PSON[#] cycle HIGH for 1 second is able to reset the power supply and the cage.

2.4.12.1 Over-Current Protection (OCP) / 240VA Protection

Each DC/DC converter output on PDB has individual OCP protection circuits. The PS+PDB combo will shutdown and latch off after an over current condition occurs. This latch is cleared by toggling the PSON[#] signal or by an AC power interruption. The following table contains the over current limits. The values are measured at the PDB harness connectors. The DC/DC converters are not damaged from repeated power cycling in this condition. Also, the +12V output from the power supply is divided on the cage into four channels and each is limited to 240VA of power. There are current sensors and limit circuits to shut down the entire power supply plus cage combo if the limit is exceeded. The limits are listed as follows.

Table 76. Over Current Protection Limits / 240VA Protection

Output Voltage	MIN OCP TRIP LIMITS	MAX OCP TRIP LIMITS
+3.3V	110% min (= 26.4A min)	150% max (= 36A max)
+5V	110% min (= 26.4A min)	150% max (= 36A max)
-12V	125% min (= 0.625A min)	400% max (= 2.0A max)
+12V1	17.5A	20Amax
+12V2	17.5A	20Amax
+12V3	17.5A	20A max
+12V4	17.5A	20A max
+5VSB	See Power Supply specification	

2.4.12.2 Over Voltage Protection (OVP)

Each DC / DC converter output on the power distribution board (PDB) has individual OVP protection circuits built in. The PS+PDB combo will shutdown and latch off after an over voltage condition occurs. This latch can be cleared by toggling the PSON[#] signal or by an AC power interruption.

The following table defines the over voltage limits. The values are measured at the PDB harness connectors.

Table 77. Over Voltage Protection (OVP) Limits

Output Voltage	OVP MIN (V)	OVP MAX (V)
+3.3V	3.9	4.5
+5V	5.7	6.5
-12V	-13.3	-14.5
+12V1/2/3/4/5	See Power Supply specification	
+5vsb	See Power Supply specification	

2.4.13 Control and Indicator Functions (Hard-wired)

The following sections define the input and output signals from the power distribution board.

Signals that can be defined as low true use the following convention:

signal[#] = low true

2.4.13.1 PSON[#] Input and Output Signals

The PSON[#] signal is required to remotely turn on/off the power supply. PSON[#] is an active low signal that turns on the +3.3V, +5V, +12V, and -12V power rails. When this signal is not pulled low by the system, or left open, the outputs (except for the +5VSB) turn off. This signal is pulled to a standby voltage by a pull-up resistor internal to the power supply.

Table 78. PSON[#] Signal Characteristics

Signal Type	Accepts an open collector/drain input from the system. Pull-up to VSB located in power supply.	
PSON [#] = Low	ON	
PSON [#] = High or Open	OFF	
	MIN	MAX
Logic level low (power supply ON)	0V	1.0V
Logic level high (power supply OFF)	2.0V	5.25V
Source current, Vpson = low		4mA
Power up delay: T _{pson_on_delay}	5msec	400msec
PWOK delay: T _{pson_pwok}		50msec

2.4.13.2 PSKILL

The purpose of the PSkill pin is to allow for hot swapping of the power supply. The mating pin of this signal on the cage input connector should be tied to ground, and its resistance is less than 5 ohms.

2.4.13.3 PWOK (Power OK) Input and Output Signals

PWOK is a power OK signal and will be pulled HIGH by the power supply to indicate that all the outputs are within the regulation limits of the power supply. When any output voltage falls below regulation limits or when AC power has been removed for a time sufficiently long so that power supply operation is no longer guaranteed, PWOK will be de-asserted to a LOW state. The start of the PWOK delay time is inhibited as long as any power supply output is in current limit.

Table 79. PWOK Signal Characteristics

Signal Type	Open collector/drain output from power supply. Pull-up to VSB located in system.	
PWOK = High	Power OK	
PWOK = Low	Power Not OK	
	MIN	MAX
Logic level low voltage, Isink=4mA	0V	0.4V
Logic level high voltage, Isource=200µA	2.4V	5.25V
Sink current, PWOK = low		4mA
Source current, PWOK = high		2mA
PWOK delay: T_{pwok_on}	100ms	1000ms
PWOK rise and fall time		100µsec
Power down delay: T_{pwok_off}	1ms	200msec

2.4.14 SMBUS Monitoring Interface

The power supply and cage provide a monitoring interface to the system over a server management bus to the system. The device is compatible with both SMBus 2.0 'high power' and I²C V_{dd} based power and drive. This bus operates at 5V. The SMBus pull-ups are located on the server board.

The SMBUS provides IPMI FRU data and failure status. Two pins have been reserved on the connector to provide this information. One pin is the Serial Clock (PSM Clock). The second pin is used for Serial Data (PSM Data). Both pins are bi-directional and are used to form a serial bus. The circuits inside the power supply are powered from the 5VSB bus and grounded to ReturnS (remote sense return).

2.5 600-Watt Power Supply

The 600-W specification defines a non-redundant power supply that supports entry server systems. This 600-W power supply has 8 outputs: 3.3V, 5V, 12V1, 12V2, 12V3, 12V4, -12V and 5Vsb. The power supply contains a single 80mm fan for cooling the power supply and part of the system.

2.5.1 Mechanical Overview

The physical size of the power supply enclosure is intended to accommodate power ranges to 600 watts. The power supply size is 150mm x 180mm x 86mm and has a wire harness for the DC outputs. The AC plugs directly into the external face of the power supply.

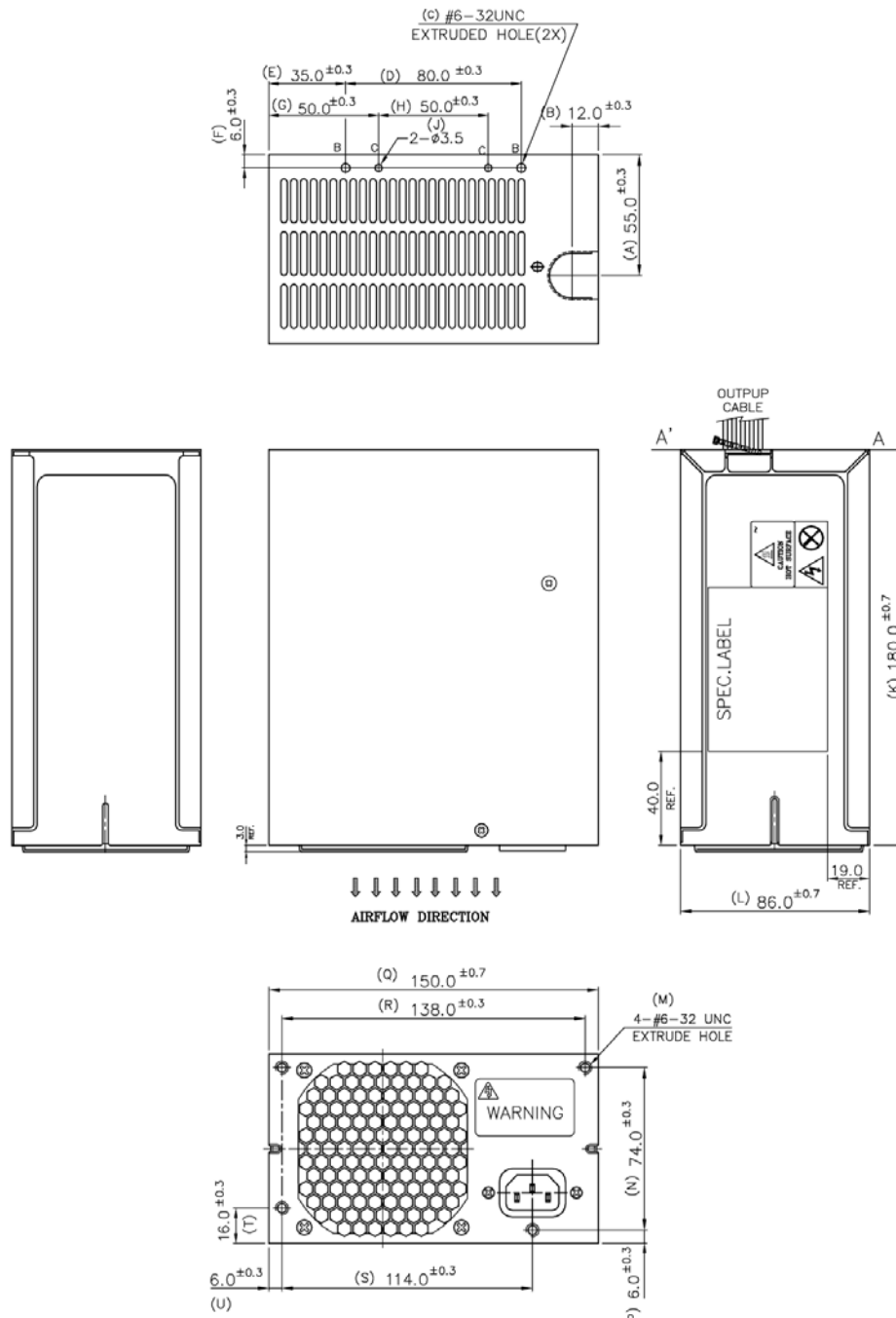

Figure 16. Mechanical Drawing for the Power Supply Enclosure

2.5.2 Airflow and Temperature

The power supply operates within all specified limits over the T_{op} temperature range. The average air temperature difference (ΔT_{ps}) from the inlet to the outlet of the power supply does not exceed 20C. All airflow passes through the power supply and not over the exterior surfaces of the power supply.

Table 80. Environmental Requirements

Item	Description	MIN	Specification	Units
T_{op}	Operating temperature range.	0	50	°C
T_{non-op}	Non-operating temperature range.	-40	70	°C
Altitude	Maximum operating altitude		1500	m

The power supply meets UL enclosure requirements for temperature rise limits. All sides of the power supply, with exception of the air exhaust side, are classified as “Handle, knobs, grips, etc. held for short periods of time only.”

2.5.3 Output Cable Harness

Listed or recognized component appliance wiring material (AVLV2), CN, rated min 105°C, 300Vdc is used for all output wiring.

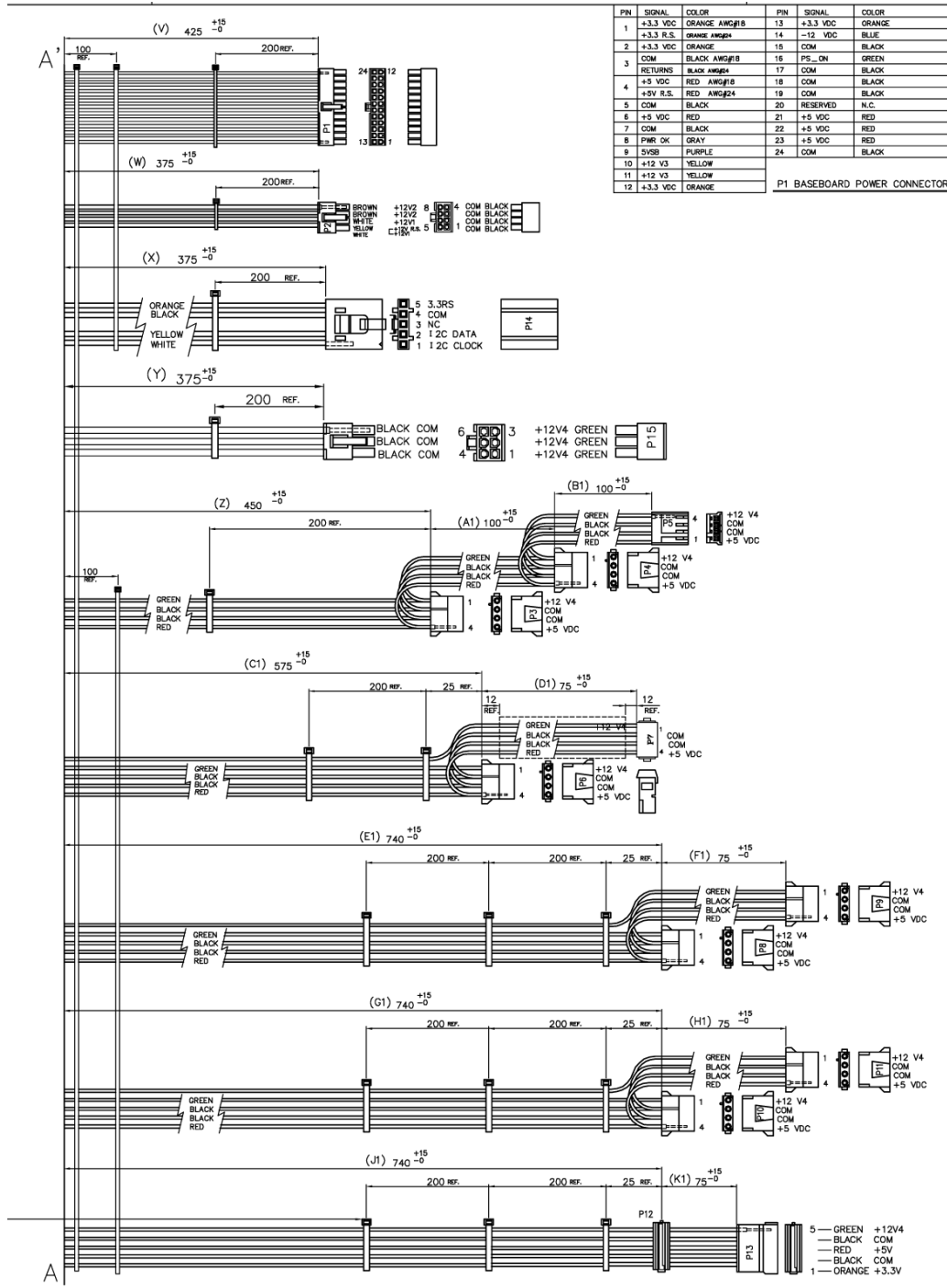

Figure 17. Output Cable Harness for 600-W Power Supply

NOTES:

1. ALL DIMENSIONS ARE IN MM
2. ALL TOLERANCES ARE +15 MM / -0 MM
3. INSTALL 1 TIE WRAP WITHIN 12MM OF THE PSU CAGE
4. MARK REFERENCE DESIGNATOR ON EACH CONNECTOR
5. TIE WRAP EACH HARNESS AT APPROX. MID POINT
6. TIE WRAP P1 WITH 2 TIES AT APPROXIMATELY 15M SPACING.

Table 81. Cable Lengths

From	To connector #	Length (mm)	No of pins	Description
Power Supply cover exit hole	P1	425	24	Baseboard Power Connector
Power Supply cover exit hole	P2	375	8	Processor Power Connector
Power Supply cover exit hole	P14	375	5	Power Signal Connector
Power Supply cover exit hole	P15	375	6	PCI Express Connector
Power Supply cover exit hole	P3	450	4	Peripheral Power Connector
Extension	P4	100	4	Peripheral Power Connector
Extension from P4	P5	100	4	Floppy Power Connector
Power Supply cover exit hole	P6	575	4	Peripheral Power Connector
Extension	P7	75 (cover with sleeve)	4	Right-angle Peripheral Power Connector
Power Supply cover exit hole	P8	740	4	Peripheral Power Connector
Extension	P9	75	4	Peripheral Power Connector
Power Supply cover exit hole	740	P10	4	Peripheral Power Connector
Extension	75	P11	4	Peripheral Power Connector
Power Supply cover exit hole	740	P12	5	Right-angle SATA Power Connector
Extension	75	P13	5	SATA Power Connector

2.5.3.1 P1 Baseboard Power Connector

Connector housing: 24- Pin Molex Mini-Fit Jr. 39-01-2245 or equivalent
 Contact: Molex Mini-Fit, HCS, Female, Crimp 44476 or equivalent

Table 82. P1 Baseboard Power Connector

Pin	Signal	18 AWG Color	Pin	Signal	18 AWG Color
1	+3.3 VDC	Orange	13	+3.3 VDC	Orange
	3.3V RS	Orange (24AWG)	14	-12 VDC	Blue
2	+3.3 VDC	Orange	15	COM	Black
3	COM	Black	16	PSO#	Green
	COM RS	Black (24 AWG)	17	COM	Black
4	+5 VDC*	Red	18	COM	Black
	5V RS	Red (24AWG)	19	COM	Black
5	COM	Black	20	Reserved	N.C.
6	+5 VDC	Red	21	+5 VDC	Red
7	COM	Black	22	+5 VDC	Red
8	PWR OK	Gray (24 AWG)	23	+5 VDC	Red
9	5VSB	Purple	24	COM	Black
10	+12V3	Yellow			
11	+12V3	Yellow			
12	+3.3 VDC	Orange			

Note: 5V Remote Sense Double Crimped

2.5.3.2 P2 Processor Power Connector

Connector housing: 8-Pin Molex 39-01-2080 or equivalent

Contact: Molex 44476-1111 or equivalent

Table 83. P2 Processor Power Connector

Pin	Signal	18 AWG Color	Pin	Signal	18 AWG Color
1	COM	Black	5	+12V1	Yellow
2	COM	Black		12V1 RS	Yellow (24 AWG)
3	COM	Black	6	+12V1	Yellow
4	COM	Black	7	+12V2	Brown
			8	+12V2	Brown

2.5.3.3 P14 Power Signal Connector

Connector housing: 5-pin Molex 50-57-9405 or equivalent

Contacts: Molex 16-02-0087 or equivalent

Table 84. Power Signal Connector

Pin	Signal	24 AWG Color
1	I ² C Clock	White
2	I ² C Data	Yellow
3	Reserved	N.C.
4	COM	Black

2.5.3.4 P15 PCI Express Connector

Connector housing: 6-pin Molex 455590002 or equivalent
 Contacts: Molex Mini-Fit, HCS, Female, Crimp 44476

Table 85. PCI Express Connector

Pin	Signal	18 AWG Color	Pin	Signal	18 AWG Color
1	+12V4	Green	4	COM	Black
2	+12V4	Green	5	COM	Black
3	+12V4	Green	6	COM	Black

2.5.3.5 P3-P4, P6, P8-P11 Peripheral Connectors

Connector housing: Amp* 1-480424-0 or equivalent
 Contact: Amp 61314-1 contact or equivalent

Table 86. Peripheral Connectors

Pin	Signal	18 AWG Color
1	+12 V3	Green
2	COM	Black
3	COM	Black
4	+5 VDC	Red

2.5.3.6 P7 Right-angle Peripheral Power Connector

Connector housing: JWT* F6001HS2-4P or equivalent

Table 87. P7 Right-angle Peripheral Power Connector

Pin	Signal	18 AWG Color
1	+12V4	Green
2	COM	Black
3	COM	Black
4	+5 VDC	Red

2.5.3.7 P5 Floppy Power Connector

Connector housing: Amp 171822-4 or equivalent
 Contact: Amp 170204-1 contact or equivalent

Table 88. P5 Floppy Power Connector

Pin	Signal	22 AWG Color
1	+5VDC	Red
2	COM	Black
3	COM	Black
4	+12V4	Green

2.5.3.8 P12 Right-angle SATA Power Connector

Connector housing: JWT F6002HS0-5P-18 or equivalent

Table 89. P12 Right-angle SATA Power Connector

Pin	Signal	18 AWG Color
1	+3.3V	Orange
2	COM	Black
3	+5VDC	Red
4	COM	Black
5	+12V4	Green

2.5.3.9 P13 SATA Power Connector

Connector housing: JWT A3811H00-5P or equivalent
 Contact: JWT A3811TOP-0D or equivalent

Table 90. P13 SATA Power Connector

Pin	Signal	18 AWG Color
1	+3.3V	Orange
2	COM	Black
3	+5VDC	Red
4	COM	Black

Pin	Signal	18 AWG Color
5	+12V4	Green

2.5.4 AC Input Requirements

The power supply operates within all specified limits over the following input voltage range, shown in the following table. Harmonic distortion of up to 10% THD must not cause the power supply to go out of specified limits. The power supply does power off if the AC input is less than 75VAC +/-5VAC range. The power supply starts up if the AC input is greater than 85VAC +/-4VAC. Application of an input voltage below 85VAC does not cause damage to the power supply, including a fuse blow.

Table 91. AC Input Rating

PARAMETER	MIN	RATED	MAX	Max Input Current	Start up VAC	Power Off VAC
Voltage (110)	90 V _{rms}	100-127 V _{rms}	140 V _{rms}	10 A _{rms}	85Vac +/-4Vac	75Vac +/-5Vac
Voltage (220)	180 V _{rms}	200-240 V _{rms}	264 V _{rms}	5 A _{rms}		
Frequency	47 Hz	50/60	63 Hz			

2.5.4.1 AC Inlet Connector

The AC input connector is an IEC 320 C-14 power inlet. This inlet is rated for 10A / 250VAC.

2.5.4.2 Efficiency

The power supply has an efficiency of 68% at maximum load and over the specified AC voltage.

2.5.4.3 AC Line Dropout / Holdup

An AC line dropout is defined to be when the AC input drops to 0VAC at any phase of the AC line for any length of time. During an AC dropout of one cycle or less the power supply meets dynamic voltage regulation requirements over the rated load. An AC line dropout of one cycle or less (20ms min) does not cause any tripping of control signals or protection circuits (= 20ms holdup time requirement). If the AC dropout lasts longer than one cycle the power will recover and meet all turn on requirements. The power supply meets the AC dropout requirement over rated AC voltages, frequencies, and output loading conditions. Any dropout of the AC line does not cause damage to the power supply.

2.5.4.3.1 AC Line 5VSB Holdup

The 5VSB output voltage stays in regulation under its full load (static or dynamic) during an AC dropout of 70ms min (=5VSB holdup time) whether the power supply is in the ON or OFF state (PSON asserted or de-asserted).

2.5.4.4 AC Line Fuse

The power supply has a single line fuse, on the Line (Hot) wire of the AC input. The line fusing is acceptable for all safety agency requirements. The input fuse is a slow blow type. AC inrush current does not cause the AC line fuse to blow under any conditions. All protection circuits in the power supply do not cause the AC fuse to blow unless a component in the power supply has failed. This includes DC output load short conditions.

2.5.4.5 AC Inrush

AC line inrush current does not exceed 50A peak for up to 10ms, after which, the input current is no more than the specified maximum input current at 265Vac input, 25 degree C and full load. The peak inrush current is less than the ratings of its critical components (including input fuse, bulk rectifiers, and surge limiting device).

The power supply meets the inrush requirements for any rated AC voltage during turn on at any phase of AC voltage, during a single cycle AC dropout condition as well as upon recovery after AC dropout of any duration, and over the specified temperature range (Top).

2.5.4.6 AC Line Surge

The power supply is tested with the system for immunity to AC Ringwave and AC Unidirectional wave, both up to 2kV, per EN 55024:1998, EN 61000-4-5:1995 and ANSI C62.45: 1992.

The power supply complies with the limits defined in EN55024: 1998 using the IEC 61000-4-5:1995 test standard and performance criteria B defined in Annex B of CISPR 24.

2.5.4.7 AC Line Transient Specification

AC line transient conditions are defined as “sag” and “surge” conditions. “Sag” conditions are also commonly referred to as “brownout,” these conditions will be defined as the AC line voltage dropping below nominal voltage conditions. “Surge” will be defined to refer to conditions when the AC line voltage rises above nominal voltage.

The power supply meets the requirements under the following AC line sag and surge conditions:

Table 92. AC Line Sag Transient Performance

Duration	Sag	Operating AC Voltage	Line Frequency	Performance Criteria
Continuous	10%	Nominal AC Voltage ranges	50/60Hz	No loss of function or performance
0 to 1 AC	95%	Nominal AC Voltage	50/60Hz	No loss of function or performance

Duration	Sag	Operating AC Voltage	Line Frequency	Performance Criteria
cycle		ranges		
> 1 AC cycle	>30 %	Nominal AC Voltage ranges	50/60Hz	Loss of function acceptable, self recoverable

Table 93. AC Line Surge Transient Performance

Duration	Surge	Operating AC Voltage	Line Frequency	Performance Criteria
Continuous	10%	Nominal AC Voltages	50/60Hz	No loss of function or performance
0 to ½ AC cycle	30%	Mid-point of nominal AC Voltages	50/60Hz	No loss of function or performance

2.5.4.8 AC Line Fast Transient (EFT) Specification

The power supply meets the EN61000-4-5 directive and any additional requirements in IEC1000-4-5: 1995 and the Level 3 requirements for surge-withstand capability, with the following conditions and exception:

- These input transients do not cause any out-of-regulation conditions, such as overshoot and undershoot, nor do they cause any nuisance trips of any of the power supply protection circuits.
- The supply meets surge-withstand conditions under maximum and minimum DC-output load conditions.

2.5.4.9 AC Line Leakage Current

The maximum leakage current to ground for each power supply is 3.5mA when tested at 240VAC.

2.5.5 DC Output Specifications

2.5.5.1 Grounding

The ground of the pins of the power supply output connector provides the power return path. The output connector ground pins are connected to safety ground (power supply enclosure).

2.5.5.2 Standby Output

The 5VSB output is present when an AC input greater than the power supply turn on voltage is applied.

2.5.5.3 Remote Sense

The power supply has remote sense return (ReturnS) to regulate out ground drops for all output voltages; +3.3V, +5V, +12V1, +12V2, +12V3, -12V, and 5VSB. The power supply uses remote sense (3.3VS) to regulate out drops in the system for the +3.3V output. The +5V, +12V1, +12V2, 12v3, -12V and 5VSB outputs only use remote sense referenced to the ReturnS signal. The remote sense input impedance to the power supply is greater than 200Ω on 3.3VS, 5VS. This is the value of the resistor connecting the remote sense to the output voltage internal to the power supply. Remote sense is able to regulate out a minimum of 200mV drop on the +3.3V output. The remote sense return (ReturnS) is able to regulate out a minimum of 200mV drop in the power ground return. The current in any remote sense line is less than 5mA to prevent voltage sensing errors. The power supply operates within specification over the full range of voltage drops from the power supply's output connector to the remote sense points.

2.5.5.4 Power Module Output Power / Currents

The following table defines power and current ratings for this 600-W power supply. The combined output power of all outputs does not exceed the rated output power. The power supply meets both static and dynamic voltage regulation requirements for the minimum loading conditions.

Table 94. Load Ratings

Load Range 1 (Max system loading)

Voltage	Minimum Continuous Load	Maximum Continuous Load ^{1, 3}	Peak Load ^{2, 4, 5}
+3.3V ⁶	1.5 A	20 A	
+5V ⁶	5.0 A	24 A	
+12V1	1.5 A	15 A	18 A
+12V2	1.5 A	15 A	18 A
+12V3	1.5 A	16 A	18 A
+12V4	1.5 A	16 A	18 A
-12V	0 A	0.5 A	
+5VSB	0.1 A	2.0 A	

Load Range 2 (Light system loading)

Voltage	Minimum Continuous Load	Maximum Continuous Load	Peak Load ⁵
+3.3V ⁶	0.5 A	9.0 A	

Voltage	Minimum Continuous Load	Maximum Continuous Load	Peak Load ⁵
+5V ⁶	2.0 A	7.0 A	
+12V1	0.5 A	5.0 A	7.0 A
+12V2	0.5 A	5.0 A	7.0 A
+12V3	2.0 A	6.0 A	
+12V4	0.5 A	5.0 A	
-12V	0 A	0.5 A	
+5VSB	0.1 A	2.0 A	

Notes:

1. Maximum continuous total DC output power should not exceed **600 W**.
2. Peak load on the combined 12V output shall not exceed **48 A**.
3. Maximum continuous load on the combined 12V output shall not exceed **43 A**.
4. Peak total DC output power should not exceed **660 W**.
5. Peak power and peak current loading shall be supported for a minimum of **12 seconds**.
6. Combined 3.3V/5V power shall not exceed **140 W**.

2.5.5.5 Voltage Regulation

The power supply output voltages stay within the following voltage limits when operating at steady state and dynamic loading conditions. These limits include the peak-peak ripple/noise. All outputs are measured with reference to the return remote sense signal (ReturnS). The +12V3, +12V4, -12V and 5VSB outputs are measured at the power supply connectors referenced to ReturnS. The +3.3V, +5V, +12V1, and +12V2 are measured at the remote sense signal located at the signal connector.

Table 95. Voltage Regulation Limits

Parameter	Tolerance	MIN	NOM	MAX	Units
+ 3.3V	- 5% / +5%	+3.14	+3.30	+3.46	V _{rms}
+ 5V	- 5% / +5%	+4.75	+5.00	+5.25	V _{rms}
+ 12V1	- 5% / +5%	+11.40	+12.00	+12.60	V _{rms}
+ 12V2	- 5% / +5%	+11.40	+12.00	+12.60	V _{rms}
+12V3	- 5% / +5%	+11.40	+12.00	+12.60	V _{rms}
+12V4	- 5% / +5%	+11.40	+12.00	+12.60	V _{rms}
- 12V	- 5% / +9%	-11.52	-12.00	-13.08	V _{rms}

Parameter	Tolerance	MIN	NOM	MAX	Units
+ 5VSB	- 5% / +5%	+4.75	+5.00	+5.25	V _{rms}

2.5.5.6 Dynamic Loading

The output voltages are within limits specified for the step loading and capacitive loading specified in the following table. The Δ step load may occur anywhere within the MIN load to the MAX load conditions.

Table 96. Transient Load Requirements

Output	Δ Step Load Size	Load Slew Rate	Test Capacitive Load
+3.3V	7.0A	0.25 A/ μ sec	4700 μ F
+5V	7.0A	0.25 A/ μ sec	1000 μ F
+12V	25A	0.25 A/ μ sec	2700 μ F
+5VSB	0.5A	0.25 A/ μ sec	20 μ F

2.5.5.7 Capacitive Loading

The power supply is stable and meets all requirements with the following capacitive loading ranges.

Table 97. Capacitive Loading Conditions

Output	MIN	MAX	Units
+3.3V	10	12,000	μ F
+5V	10	12,000	μ F
+12V(1, 2, 3)	500 each	11,000	μ F
+12V4	10	500	μ F
-12V	1	350	μ F
+5VSB	20	350	μ F

2.5.5.8 Closed Loop Stability

The power supply is unconditionally stable under all line/load/transient load conditions, including capacitive load ranges. A minimum of: **45 degrees phase margin** and **-10dB-gain margin** is required. Closed-loop stability is ensured at the maximum and minimum loads as applicable.

2.5.5.9 Ripple / Noise

The maximum allowed ripple/noise output of the power supply is defined in the following table. This is measured over a bandwidth of 10Hz to 20MHz at the power supply output connectors.

Table 98. Ripple and Noise

+3.3V	+5V	+12V1/2	-12V	+5VSB
50mVp-p	50mVp-p	120mVp-p	120mVp-p	50mVp-p

2.5.5.10 Timing Requirements

The timing requirements for power supply operation are as follows. The output voltages must rise from 10% to within regulation limits (T_{vout_rise}) within 5 to 70ms, except for 5VSB - it is allowed to rise from 1.0 to 70ms. The +3.3V, +5V and +12V output voltages should start to rise approximately at the same time. **All outputs must rise monotonically.** The +5V output needs to be greater than the +3.3V output during any point of the voltage rise. The +5V output must never be greater than the +3.3V output by more than 2.25V. Each output voltage shall reach regulation within 50ms (T_{vout_on}) of each other during turn on of the power supply. Each output voltage shall fall out of regulation within 400msec (T_{vout_off}) of each other during turn off. The following table shows the timing requirements for the power supply being turned on and off via the AC input, with PSON held low and the PSON signal, with the AC input applied.

Table 99. Output Voltage Timing

Item	Description	Minimum	Maximum	Units
T_{vout_rise}	Output voltage rise time from each main output.	5.0 *	70 *	msec
T_{vout_on}	All main outputs must be within regulation of each other within this time.		50	msec
T_{vout_off}	All main outputs must leave regulation within this time.		400	msec

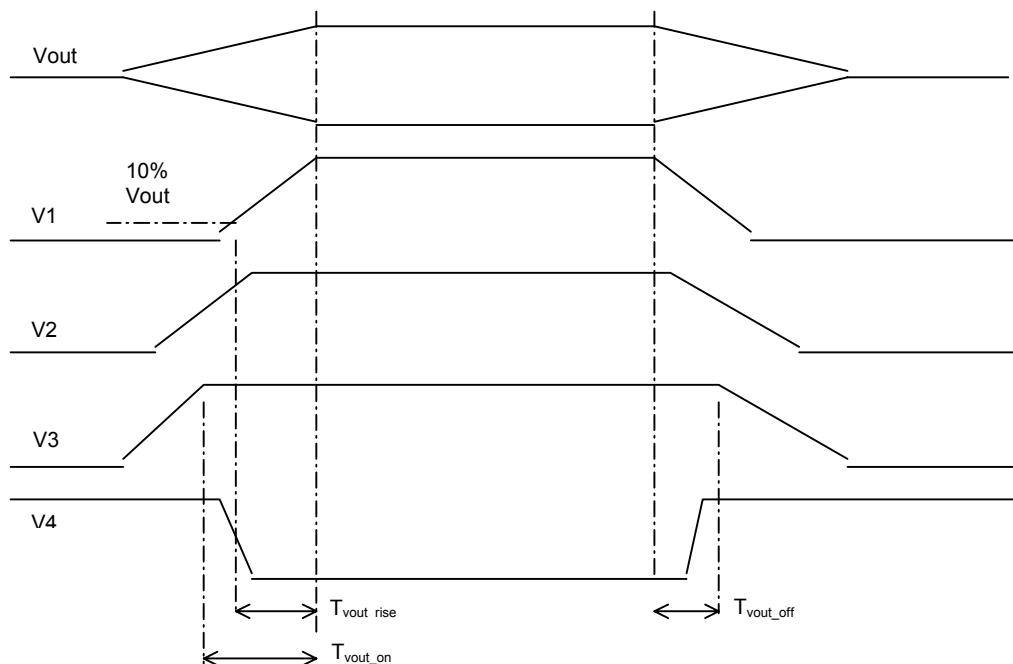

Figure 18. Output Voltage Timing

Table 100. Turn On / Off Timing

Item	Description	Minimum	Maximum	Units
$T_{sb_on_delay}$	Delay from AC being applied to 5VSB being within regulation.		1500	msec
$T_{ac_on_delay}$	Delay from AC being applied to all output voltages being within regulation.		2500	msec
T_{vout_holdup}	Time all output voltages stay within regulation after loss of AC.	21		msec
T_{pwok_holdup}	Delay from loss of AC to de-assertion of PWOK	20		msec
$T_{pson_on_delay}$	Delay from PSON [#] active to output voltages within regulation limits.	5	400	msec
T_{pson_pwok}	Delay from PSON [#] deactive to PWOK being de-asserted.		50	msec
T_{pwok_on}	Delay from output voltages within regulation limits to PWOK asserted at turn on.	100	1000	msec
T_{pwok_off}	Delay from PWOK de-asserted to output voltages (3.3V, 5V, 12V, -12V) dropping out of regulation limits.	1	200	msec

Item	Description	Minimum	Maximum	Units
T _{pwok_low}	Duration of PWOK being in the de-asserted state during an off/on cycle using AC or the PSON signal.	100		msec
T _{sb_vout}	Delay from 5VSB being in regulation to O/Ps being in regulation at AC turn on.	50	1000	msec
T _{5VSB_holdup}	Time the 5VSB output voltage stays within regulation after loss of AC.	70		msec

2.5.5.11 Residual Voltage Immunity in Standby Mode

The power supply is immune to any residual voltage placed on its outputs (Typically a leakage voltage through the system from standby output) up to 500mV. There is neither additional heat generated, nor stress of any internal components with this voltage applied to any individual output, and all outputs simultaneously. It also does not trip the protection circuits during turn on.

The residual voltage at the power supply outputs for no load condition does not exceed 100mV when AC voltage is applied.

2.5.6 Protection Circuits

Protection circuits inside the power supply cause only the power supply's main outputs to shutdown. If the power supply latches off due to a protection circuit tripping, an AC cycle OFF for 15sec and a PSON# cycle HIGH for 1sec will reset the power supply.

2.5.6.1 Over-Current Protection (OCP)

The power supply has a current limit to prevent the +3.3V, +5V, and +12V outputs from exceeding 240VA. If the current limits are exceeded the power supply will shutdown and latch off. The latch will be cleared by toggling the PSON# signal or by an AC power interruption. The power supply will not be damaged from repeated power cycling in this condition. -12V and 5VSB are protected under over current or shorted conditions so that no damage can occur to the power supply. Auto-recovery feature exists on the 5VSB rail.

Table 101. Over Current Protection (OCP)

Voltage	Over Current Limit	
	MIN	MAX
+3.3V	26.4A	36A
+5V	26.4A	36A
+12V1	18A	20A
+12V2	18A	20A
+12V3	18A	20A

Voltage	Over Current Limit	
	MIN	MAX
+12V4	18A	20A
-12V	0.625A	4A
5VSB	N/A	8A

2.5.6.2 Over Voltage Protection (OVP)

The power supply over voltage protection is locally sensed. The power supply will shutdown and latch off after an over voltage condition occurs. This latch can be cleared by toggling the PSON[#] signal or by an AC power interruption. The following table contains the over voltage limits. The values are measured at the output of the power supply's connectors. The voltage never exceeds the maximum levels when measured at the power pins of the power supply connector during any single point of fail. The voltage will not trip any lower than the minimum levels when measured at the power pins of the power supply connector.

Exception: The +5VSB rail will recover after its over voltage condition occurs.

Table 102. Over Voltage Protection Limits

Output Voltage	MIN (V)	MAX (V)
+3.3V	3.9	4.5
+5V	5.7	6.5
+12V1,2,	13.3	14.5
-12V	-13.3	-16
+5VSB	5.7	6.5

2.5.6.3 Over Temperature Protection (OTP)

The power supply is protected against over temperature conditions caused by loss of fan cooling or excessive ambient temperature. In an OTP condition the PSU will shutdown. When the power supply temperature drops to within specified limits, the power supply will restore power automatically, while the 5VSB remains always on. The OTP circuit has a built in hysteresis such that the power supply will not oscillate on and off due to a temperature recovering condition. The OTP trip level has a minimum of 4°C of ambient temperature hysteresis.

2.5.7 Control and Indicator Functions

The following sections define the input and output signals from the power supply.

Signals that can be defined as low true use the following convention:

Signal[#] = low true

2.5.7.1 PSON[#] Input Signal

The PSON[#] signal is required to remotely turn on/off the power supply. PSON[#] is an active low signal that turns on the +3.3V, +5V, +12V, and -12V power rails. When this signal is not pulled low by the system, or left open, the outputs (except the +5VSB) turn off. This signal is pulled to a standby voltage by a pull-up resistor internal to the power supply.

Table 103. PSON[#] Signal Characteristic

Signal Type	Accepts an open collector/drain input from the system. Pull-up to VSB located in power supply.	
PSON [#] = Low	ON	
PSON [#] = High or Open	OFF	
	MIN	MAX
Logic level low (power supply ON)	0V	1.0V
Logic level high (power supply OFF)	2.1V	5.25V
Source current, Vpson = low		4mA
Power up delay: T _{pson_on_delay}	5msec	400msec
PWOK delay: T _{pson_pwok}		50msec

2.5.7.2 PWOK (Power OK) Output Signal

PWOK is a power OK signal and is pulled HIGH by the power supply to indicate that all the outputs are within the regulation limits of the power supply. When any output voltage falls below regulation limits or when AC power has been removed for a time sufficiently long so that power supply operation is no longer guaranteed, PWOK will be de-asserted to a LOW state. The start of the PWOK delay time is inhibited as long as any power supply output is in current limit.

Table 104. PWOK Signal Characteristics

Signal Type	Open collector/drain output from power supply. Pull-up to VSB located in system.	
PWOK = High	Power OK	
PWOK = Low	Power Not OK	
	MIN	MAX
Logic level low voltage, Isink=4mA	0V	0.4V
Logic level high voltage, Isource=200μA	2.4V	5.25V
Sink current, PWOK = low		4mA
Source current, PWOK = high		2mA
PWOK delay: T_{pwok_on}	100ms	1000ms
PWOK rise and fall time		100μsec
Power down delay: T_{pwok_off}	1ms	200msec

3. Chassis Cooling

3.1 Fan Configuration

The cooling sub-system in the Intel® Entry Server Chassis SC5295-E consists of one system fan and one power supply fan. A 120mm x 38mm fan provides cooling at the rear of the chassis by drawing fresh air into the chassis from the front and exhausting warm air out of the system. Removal and insertion of the 120mm fan can be done without tools. The power supply fan assists in drawing air through the peripheral bay area, through the power supply and exhausting it out the rear of the chassis. All versions of the Intel® Entry Server Chassis SC5295-E are optimized for server and workstation boards that have an active CPU heat sink solution.

If an optional hot-swap drive bay is installed, a 4-wire 92mm fan is included with the mounting bracket kit for installation onto the drive bay. This fan has a PWM circuit that allows the server board to control the fan speed based on sensor readings of ambient temperature.

In addition to these pre-installed fans, locations for three additional fans are provided for customized configurations. Intel does not provide order part numbers for these customizable fan options. A 120-mm fan can be mounted to the rear of the PCI card guide and provide additional cooling to the PCI card area and two 80-mm fans can be mounted at the front of the chassis to the right of the hard drive bay opening to provide more cooling.

The front panel in the Intel® Entry Server Chassis SC5295-E provides a LM30 temperature sensor for SIO control. Server boards that support SIO control may use the LM30 sensor to adjust fan speeds according to air intake temperatures. Refer to the server board documentation for configuring use of the front panel sensor.

3.1.1 Intel® Entry Server Chassis SC5295-E UP/DP/BRP Fan Configuration

The server chassis, SC5295UP, SC5295DP and SC5295BRP, feature a 4-wire 120mm fan mounted at the rear. This fan is PWM controlled. The server board will monitor an ambient temperature sensor and adjust the duty cycle of the PWM signal to drive the fan at the appropriate speed.

3.1.2 Intel® Entry Server Chassis SC5295-E WS Fan Configuration

The workstation chassis, SC5295WS, is designed to work with the Intel® Server Board SE7525RP2. The workstation cooling design dramatically reduces system-level acoustics making it an effective solution when acoustics is a concern. The workstation chassis ships with a 50-mm fan to provide additional cooling to server board memory. This fan is voltage controlled by the server board. Fan speed will be adjusted based on the ambient temperature sensor if support is included on the server board. The workstation chassis also features a rear-mounted 120-mm thermostat controlled fan that self regulates fan speed based on air temperature. The thermostat is mounted on the hub of the fan.

The latest BIOS version is required to be configured for proper performance. In addition, it is recommended that system fans be connected to the Intel® server board SYS Fan header #1 and SYS Fan header #3 for the chassis fans.

3.2 Server Board Fan Control

The fans provided in the Intel® Entry Server Chassis SC5295-E contain a tachometer signal that can be monitored by the Server Management subsystem for the Intel® Server Board SE7320EP2, SE7525RP2, and SE7230NH1-E. See the specific baseboard Technical Product Specification for details on how this feature works.

3.3 Cooling Solution

Air should flow through the system from front to back as indicated by the arrows in the following figure.

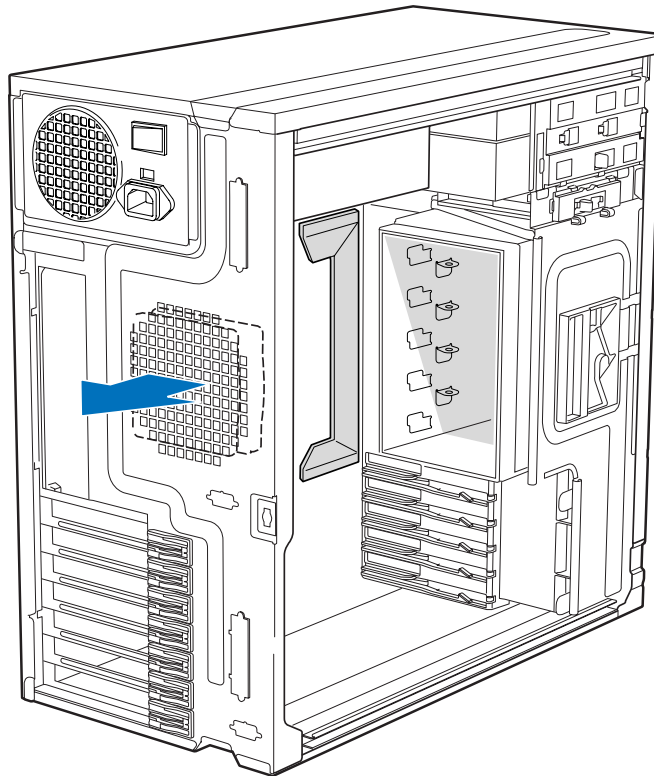

TP00869

Figure 19. Cooling Fan Configuration

The Intel® Entry Server Chassis SC5295-E is engineered to provide sufficient cooling for all internal components of the server. The cooling subsystem is dependent upon proper airflow. The designated cooling vents on both the front and back of the chassis must be left open and must not be blocked by improperly installed devices. All internal cables must be routed in a manner that does not impede airflow, and ducting provided for CPU cooling must be installed.

Active heat sinks for CPUs incorporate a fan to provide cooling. This thermal solution is included with some boxed Intel® Xeon™ and Intel® Pentium® processors. The Intel® Entry Server Chassis SC5295-E is engineered to work with processors that have an active heat sink

solution. Proper installation of the processor cooling solution is required for circulating air toward the rear of the chassis (toward I/O connectors).

4. Peripheral and Hard Drive Support

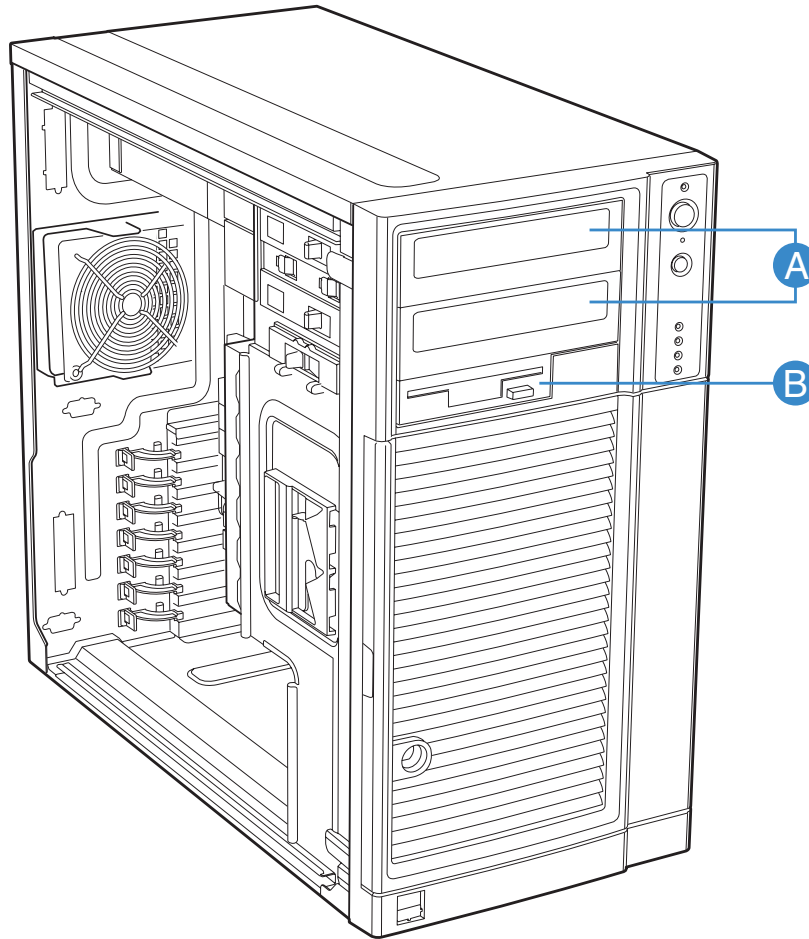

TP00870

- A. Hard Disk Drive Bay
- B. Two 5.25-in Peripheral Drive Bays
- C. 3.5-in Peripheral Drive Bay

Figure 20. Drive Bay Locations for Intel® Entry Server Chassis SC5295-E

4.1 3.5-in Peripheral Drive Bay

The Intel® Entry Server Chassis SC5295-E supports one 3.5-in peripheral, such as a floppy or tape drive, below the 5.25-in peripheral bays. The bezel must be removed prior to floppy drive installation. When a drive is not installed, a snap-in EMI shield must be in place to ensure regulatory compliance. A cosmetic plastic filler is provided to snap into the bezel.

The 3.5-in bay is designed for tool-less insertion and removal so that no screws are required. On the right side of the chassis, two protrusions in the sheet metal help locate the drive. On the left side are two levers to lock the drive into place.

4.2 5.25-in Peripheral Drive Bays

The Intel® Entry Server Chassis SC5295-E supports two half-height 5.25-in removable media peripheral devices, such as a magnetic/optical disk, CD-ROM drive, or tape drive. These peripherals can be up to 9 inches (228.6 mm) deep on the non-redundant power chassis. The 500-W redundant power supply is longer in length and will limit the drives to approximately 7.5-in maximum length. As a guideline, the maximum recommended power per device is 17W. Thermal performance of specific devices must be verified to ensure compliance to the manufacturer's specifications.

The 5.25-in peripherals can be inserted and removed without tools from the front of the chassis after taking off the access cover and removing the front bezel. The peripheral bay utilizes visual guide holes to correctly line up the position of peripheral drives. Locking slide levers push retaining pins into the drive to hold it securely in the bay. EMI shield panels are installed and should be retained in unused 5.25-in bays to ensure proper cooling and EMI conformance.

Note: Use caution when approaching the maximum level of integration for the 5.25-in drive bays. Power consumption of the devices integrated needs must be carefully considered to ensure that the maximum power levels of the power supply are not exceeded.

4.3 Hard Disk Drive Bays

4.3.1 Fixed Hard Drive Bay

The Intel® Entry Server Chassis SC5295-E comes with a removable hard drive bay that can accept up to six cabled 3.5-in x 1-in hard drives. Power requirements for each individual hard drive may limit the maximum number of drives that can be integrated into a Intel® Entry Server Chassis SC5295-E. The drive bay is designed to allow adequate airflow between drives and no additional cooling fan is required. Drives must be installed in the order of slot 1, 3, 5 first (skipping slots) to ensure proper cooling. The drive bay is secured with a tool-less retention mechanism.

Note: The hard drive bay must be pushed forward or removed to install the baseboard.

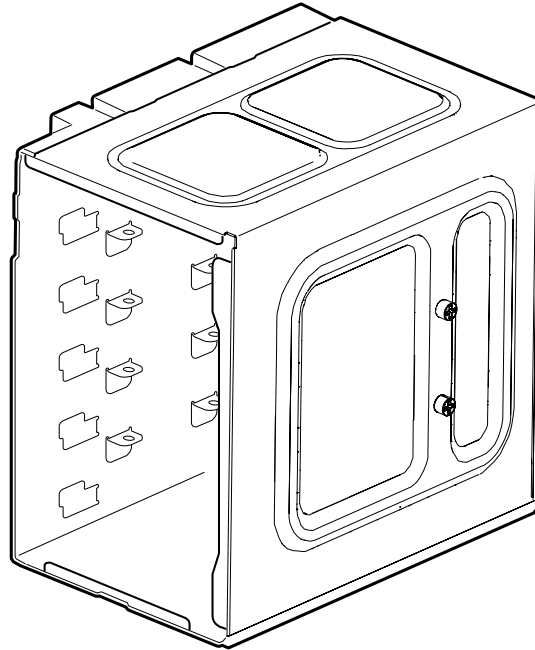

TP00873

Figure 21. 6-HDD Fixed Drive Bay, Rear Isometric View

The Intel® Entry Server Chassis SC5295-E is capable of accepting a single SCSI or SATA hot swap backplane hard drive enclosure in place of the fixed drive bay. The SCSI backplane is a LVD design, which provides support for SCSI devices using Low Voltage Differential Signaling. Both backplanes have a connector to accommodate a SAF-TE controller on an add-in card. Each backplane type supports up to six 1-in hot swap drives when mounted in the docking drive carrier.

4.3.2 6HDD SCSI Hot-Swap Backplane (HSBP) Overview

The Intel® Entry Server Chassis SC5295-E 6HDD SCSI HSBP is a monolithic printed circuit board. The architecture is based on the QLogic* GEM359 enclosure management controller and has support for up to 6 SCSI drives.

The 6HDD SCSI HSBP supports the following feature set:

- QLogic* GEM359 enclosure management controller
- External non-volatile Flash ROM
- Two I²C interfaces
- Low Voltage Differential (LVD) SCSI Interface
- SCSI-3 compatible
- Compliance with SCSI Accessed Fault Tolerant Enclosures (SAF-TE) specification, version 1.00 and addendum
- Compliance with Intelligent Platform Management Interface (IPMI)
- Support for up to 6 U320 LVD SCSI Drives

- Onboard LVD SCSI Termination
- Hot Swap Power Controller
- Temperature Sensor
- FRU EEPROM
- Two 4-pin Standard HD Power Connectors

4.3.2.1 SCSI Enclosure Management Controller

The QLogic* GEM359 enclosure management controller for the SCSI backplane monitors various aspects of a storage enclosure. The chip provides in-band SAF-TE and SES management through the SCSI interface. The GEM359 also supports the IPMI specification by providing management data to a baseboard management controller through the IPMB.

The hot-swap SCSI backplane board set resides in the hot-swap drive bay, which is available as an upgrade.

The SCSI interface on the LVD SCSI backplane provides the link between the SCSI bus and the SCSI Accessed Fault Tolerant Enclosure (SAF-TE) controller. The SAF-TE interface allows the enclosure management controller to respond as a SCSI target to implement the SAF-TE protocol.

Power control on the LVD SCSI backplane supports the following features.

- Spin-down of a drive when failure is detected and reported (using enclosure services messages) via the SCSI bus. An application or RAID controller detects a drive-related problem that indicates a data risk. In response, it removes the drive from service and sends a spin-down SCSI command to the drive. This decreases the likelihood that the drive will be damaged during removal from the hot-swap drive bay. When a new drive is inserted, the power control waits a small amount of time for the drive to be fully seated, and then applies power with a controlled power ramp.
- If the system power is on, the LVD SCSI backplane immediately powers off a drive slot when it detects that a drive has been removed. This prevents possible damage to the drive when it is partially removed and re-inserted while full power is available and disruption of the entire SCSI array from possible sags in supply voltage and resultant current spikes.

4.3.2.2 SCSI Interface

The GEM359 controller supports LVD SCSI operation through an 8-bit asynchronous SCSI data transfers.

The GEM359 controller supports two independent I²C interface ports. This enables actual temperature value readings to be returned to the host. The Intelligent Platform Management Bus (IPMB) is supported through the I²C port 1.

4.3.2.2.1 Temperature Sensor

The hot-swap backplane provides a temperature sensor with over-temperature detection. The host can query the backplane at any time to read the temperature. The host can program both the temperature alarm threshold and the temperature at which the alarm condition goes away.

4.3.2.2.2 Serial EEPROM

The backplane provides an Atmel* 24C02 or equivalent serial EEPROM for storing the FRU information. The EEPROM provides 2048 bits of serial electrically erasable and programmable read-only memory.

4.3.2.3 External Memory Device

The backplane contains a non-volatile 16K Top Boot Block, 4Mbit Flash memory device that stores the configuration data and operating firmware executed by the GEM359 controller's internal CPU.

4.3.2.4 SCSI Drive Connectors

The backplane provides SCA2 connectors for hot swappable drives with support up to the Ultra-320 LVD transfer rate. The HSBP only supports LVD mode, and not SE or HVD mode.

The HSBP provides one 68-pin SCSI connector to cable back to the Host System.

The HSBP provides active termination, termination voltage, a reset-able fuse, and a protection diode for SCSI channel. By design, the on-board termination cannot be disabled.

4.3.2.5 Power Connectors

The SCSI HSBP provides two standard 4-pin hard drive power connectors. The following table defines the pin-out for the 4-pin power connector.

Table 105. Power Connector Pin-out

Pin	Signal
1	12V
2	GND
3	GND
4	5V

4.3.2.6 SCA2 SCSI Connector

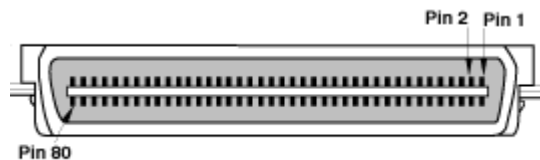

Figure 22. 68-Pin SCSI Cable Connector

The following table defines the pin-out for the 80-pin SCA2 SCSI Connector.

Table 106. SCA2 SCSI Connector Pin-out

Connector Contact Number	Signal Name	Signal Name	Connector Contact Number
1	12V CHARGE	12V GND	41
2	12V	12V GND	42
3	12V	12V GND	43
4	12V	MATED 1	44
5	OPT 3.3V	3.3V CHARGE	45
6	OPT 3.3V	DIFFSNS	46
7	-DB(11)	+DB(11)	47
8	-DB(10)	+DB(10)	48
9	-DB(9)	+DB(9)	49
10	-DB(8)	+DB(8)	50
11	-I/O	+I/O	51
12	-REQ	+REQ	52
13	-C/D	+C/D	53
14	-SEL	+SEL	54
15	-MSG	+MSG	55
16	-RST	+RST	56
17	-ACK	+ACK	57
18	-BSY	+BSY	58
19	-ATN	+ATN	59
20	-DB(P)	+DB(P)	60
21	-DB(7)	+DB(7)	61
22	-DB(6)	+DB(6)	62
23	-DB(5)	+DB(5)	63
24	-DB(4)	+DB(4)	64

Connector Contact Number	Signal Name	Signal Name	Connector Contact Number
25	-DB(3)	+DB(3)	65
26	-DB(2)	+DB(2)	66
27	-DB(1)	+DB(1)	67
28	-DB(0)	+DB(0)	68
29	-DB(P1)	+DB(P1)	69
30	-DB(15)	+DB(15)	70
31	-DB(14)	+DB(14)	71
32	-DB(13)	+DB(13)	72
33	-DB(12)	+DB(12)	73
34	5V	MATED 2	74
35	5V	5V GND	75
36	5V CHARGE	5V GND	76
37	SPINDLE SYNC	ACT LED OUT	77
38	RMT START	DLYD START	78
39	SCSI ID(0)	SCSI ID(1)	79
40	SCSI ID(2)	SCSI ID(3)	80

4.3.2.7 68-Pin SCSI Connector

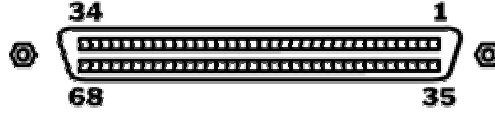

Figure 23. 68-Pin SCSI Cable Connector

The following table defines the pin-out for the 68-pin SCSI Connector.

Table 107. 68-pin SCSI Connector Pin-out

Connector Contact Number	Signal Name	Signal Name	Connector Contact Number
1	+DB(12)	-DB(12)	35
2	+DB(13)	-DB(13)	36
3	+DB(14)	-DB(14)	37
4	+DB(15)	-DB(15)	38
5	+DB(P1)	-DB(P1)	39
6	+DB(0)	-DB(0)	40
7	+DB(1)	-DB(1)	41
8	+DB(2)	-DB(2)	42
9	+DB(3)	-DB(3)	43
10	+DB(4)	-DB(4)	44
11	+DB(5)	-DB(5)	45
12	+DB(6)	-DB(6)	46
13	+DB(7)	-DB(7)	47
14	+DB(P)	-DB(P)	48
15	GROUND	GROUND	49
16	DIFFSENSE	GROUND	50
17	TERMPWR	TERMPWR	51
18	TERMPWR	TERMPWR	52
19	RESERVED	RESERVED	53

Connector Contact Number	Signal Name	Signal Name	Connector Contact Number
20	GROUND	GROUND	54
21	+ATN	-ATN	55
22	GROUND	GROUND	56
23	+BSY	-BSY	57
24	+ACK	-ACK	58
25	+RST	-RST	59
26	+MSG	-MSG	60
27	+SEL	-SEL	61
28	+C/D	-C/D	62
29	+REQ	-REQ	63
30	+I/O	-I/O	64
31	+DB(8)	-DB(8)	65
32	+DB(9)	-DB(9)	66
33	+DB(10)	-DB(10)	67
34	+DB(11)	-DB(11)	68

4.3.2.8 IPMB (I²C) Header

The following table defines the pin-out for the 4-pin IPMB Header at J1.

Table 108. IPMB Header Pin-out

Pin	Signal Name	Description
1	N/C	
2	BP_I2C_SCL	Clock
3	GND	
4	BP_I2C_SDA	Data

4.3.2.9 Power Budget

The following table shows the worst-case power budget for the 6HDD SCSI HSBP.

Table 109. Hot Swap Backplane Worst-case Power Budget

Intel® Entry Server Chassis SC5295-E 6HDD SCSI HSBP	12V	5V
Backplane	0.1A	2.0A
6HDD	10.0A	10.0A
Total Current	10.1A	12.0A

4.3.2.10 Hard Drive Activity and Fault LED

The SCSI HSBP contains a green ACTIVITY LED and a yellow FAULT LED for each of the six drive connectors. The ACTIVITY LED is driven by the SCSI hard drive itself whenever the drive is accessed. The FAULT LED is driven by the GEM359 controller whenever an error condition, as defined by the firmware, is detected.

Table 110. Hard Drive Activity LED

Drive	HSBP LED Activated	6 HDD Bay LED Designator	Fault LED Color	Activity LED Color
1	Drive 0 - Conn 2	D1	Yellow	Green
2	Drive 1 – Conn 3	D2	Yellow	Green
3	Drive 2 – Conn 4	D3	Yellow	Green
4	Drive 3 – Conn 5	D4	Yellow	Green
5	Drive 4 – Conn 6	D5	Yellow	Green
6	Drive 5 – Conn 7	D6	Yellow	Green

The hot-swap controller (HSC) is responsible for turning the drive fault LEDs on or off according to the states specified via commands received from SAF-TE and the IMB. The drive fault LEDs are yellow and indicate failure status for each drive. The LEDs are physically located on the LVD SCSI backplane.

The LEDs are 4-terminal dual-color (yellow and green) and are physically located on the backplane.

4.3.2.11 SCSI Backplane Status LEDs

Each SCSI back plane has two status LEDs used to indicate system fail or system alarm. These LED's are located on the power connector side of the SCSI back plane and are visible from the interior of the chassis.

Table 111. SCSI Backplane LED

Backplane	LED Designator	Signal Name
6 HDD	D7	SYS_FAIL
6 HDD	D8	SYS_ALARM

The following are isometric views of the SCSI back plane assemblies.

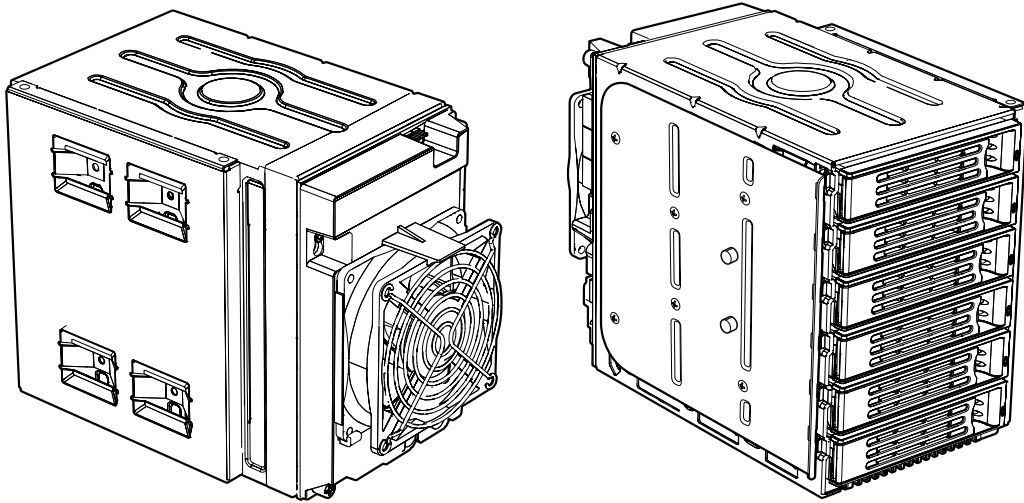

TP00871

Figure 24. 6 HDD Hot Swap Drive Bay, Rear / Front Isometric View

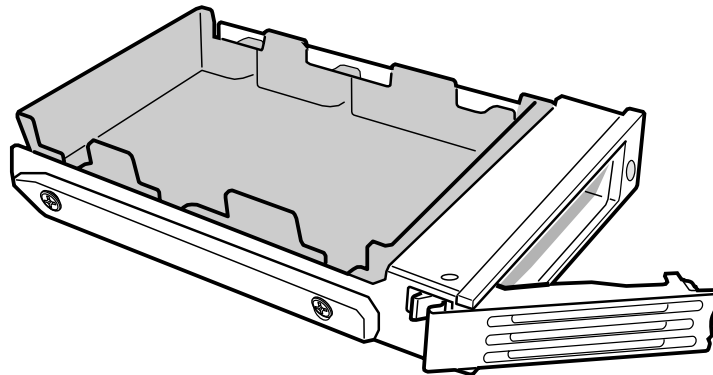

TP00927

Figure 25. Drive Carrier with Air Baffle Installed

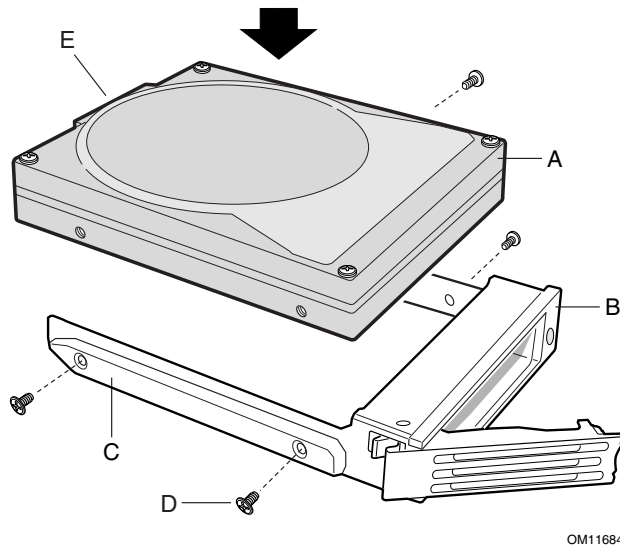

Figure 26. Hard Drive Carrier Assembly

4.3.2.12 SCSI Hot Swap Drive Cage Upgrade Kit

The SCSI HSBP drive cage allows for installation of up to six SCSI drives in the server. With this kit, the SCSI hot swap drive cage can be directly connected to the SCSI connectors on a SCSI RAID card or to a server board with integrated SCSI. The RAID level that is supported depends on the feature set of the SCSI controller.

Kit Order Codes

AXX6SCSIDB

APP3HSDBKIT

4.3.3 Serial-ATA (SATA) Hot Swap Back Plane (HSBP)

The Intel® Entry Server Chassis SC5295-E 6HDD SATA HSBP is a monolithic printed circuit board. The architecture is based on the QLogic* GEM424 enclosure management controller and has support for up to six SATA drives.

The Intel® Entry Server Chassis SC5295-E 6HDD SATA HSBP supports the following feature set:

- QLogic* GEM424 enclosure management controller
- External non-volatile SEEPROMs
- Three I²C interfaces
- SATA and SATA-II extension compatible
- Compliance with SATA Accessed Fault Tolerant Enclosures (SAF-TE) specification, version 1.00 and addendum
- Compliance with Intelligent Platform Management Interface 1.5 (IPMI)
- Support for up to six 1.5GHz SATA Drives

- Hot Swap Drive support
- Temperature Sensor
- FRU EEPROM
- Two 4-pin Standard HD Power Connectors

The following figure shows the functional blocks of the SATA HSBP.

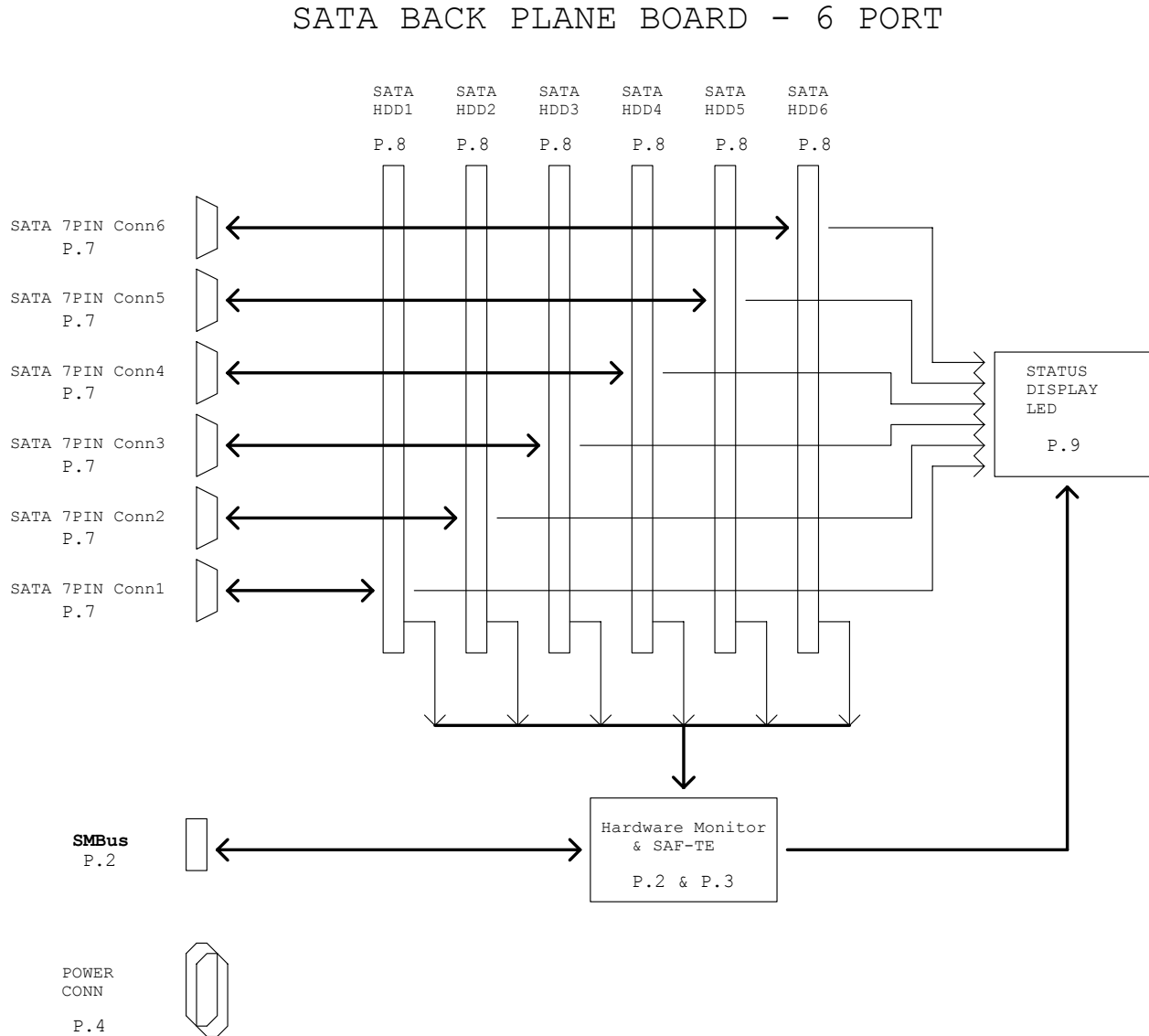

Figure 27. Intel® Entry Server Chassis SC5295-E 6HDD SATA HSBP Block Diagram

4.3.3.1 SATA Enclosure Management Controller

The QLogic* GEM424 enclosure management controller for the SATA backplane monitors various aspects of the storage enclosure. The chip provides out-of-band SAF-TE management through the SATA Host I²C interface. The GEM424 also supports the IPMI specification by providing management data to a baseboard management controller through the IPMB.

The GEM424 controller has general input and output pins (GPIOs) that allow customization. These GPIOs are used for hardware drive detection and driving FAULT and ACTIVITY LEDs.

The GEM424 controller comes in an 80-pin Thin Quad Flat Pack (TQFP) package and operates from 3.3V and an input clock frequency of 20MHz.

4.3.3.2 SATA Interface

The GEM424 controller implements SAF-TE over the HBA I²C interface. The GEM424 controller supports the following SAF-TE Command Set:

- Read Enclosure Configuration
- Read Enclosure Status
- Read Device Slot Status
- Read Global Flags
- Write Device Slot Status
- Perform Slot Operation

4.3.3.3 I²C Serial Bus Interface

The GEM424 controller supports two independent I²C interface ports with bus speeds of up to 400Kbits. The I²C core incorporates 8-bit FIFOs for data transfer buffering. The I²C bus supports a National* LM75 or equivalent I²C -based temperature sensor. This enables actual temperature value readings to be returned to the host. The Intelligent Platform Management Bus (IPMB) is supported through the I²C port 0.

The following figure provides a block diagram of I²C bus connection implemented on the 6HDD SATA HSBP.

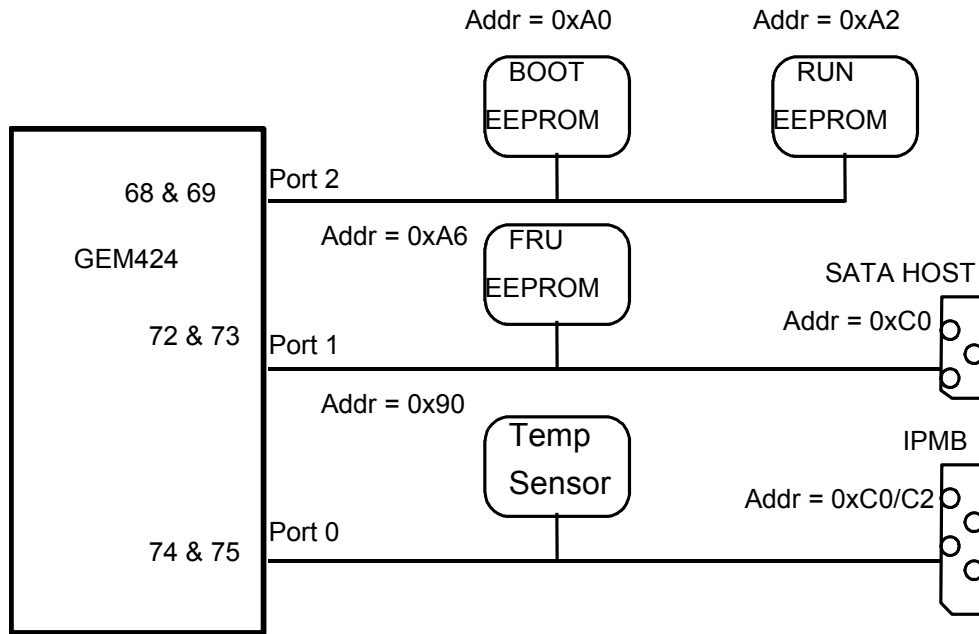

Figure 28. Intel® Entry Server Chassis SC5295-E 6HDD SATA Hot Swap Backplane I²C Bus Connection Diagram

4.3.3.3.1 I²C Bus Address and Loading

Table 112. I²C Bus Addressing

LM75 I²C Address	24C128 EEPROM I²C	24C512 EEPROM I²C	24C02 EEPROM I²C
90h	A0h	A2h	A6h

Table 113. I²C Bus Loading

Device	Power Well	ViH	ViL	VoL	Ileak	CAP	I²C Address	I²C Bus Name
LM75	P5V	0.7VCC	0.3VCC	0.4V/3mA	6uA	20PF	94h	SDA0,SCL0
GEM424	P5V	0.7VCC	0.3VCC	0.4V/3mA	10uA	4PF	GEM424 allot	SDA0,SCL0
J13	P5V	0.7VCC*	0.3VCC*	0.4V/3mA*	10uA*	4/8P*	*	SDA0,SCL0
GEM424	P5V	0.7VCC	0.3VCC	0.4V/3mA	10uA	4PF	GEM424 allot	SDA1,SCL1
JP1	P5V	0.7VCC*	0.3VCC*	0.4V/3mA*	10uA*	4/8P*	*	SDA1,SCL1
GEM424	P5V	0.7VCC	0.3VCC	0.4V/3mA	10uA	4PF	GEM424	SDA2,SCL2

Device	Power Well	ViH	ViL	VoL	Ileak	CAP	I ² C Address	I ² C Bus Name
							allot	
PCA9554	P5V	0.7VCC	0.3VCC	0.4/3mA	10uA	10PF	40h	SDA2,SCL2
AT24C512	P5V	0.7VCC	0.3VCC	0.4V/2.1mA	3uA	8PF	A2h	SDA2,SCL2
AT24C128	P5V	0.7VCC	0.3VCC	0.4V/2.1mA	3uA	8PF	A0h	SDA2,SCL2
AT24C02	P5V	0.7VCC	0.3VCC	0.4V/2.1mA	3uA	8PF	A6h	SDA2,SCL2
JP2	P5V	0.7VCC*	0.3VCC*	0.4V/3mA*	10uA*	4/8P*	*	SDA2,SCL2

4.3.3.3.2 *Temperature Sensor*

The 6HDD SATA HSBP provides a National* LM75 or equivalent temperature sensor. The host can query the LM75 at any time to read the temperature.

The temperature sensor has an I²C address of 0x90h on Port 0 of the GEM424 controller.

4.3.3.3.3 *Serial EEPROM*

The 6HDD SATA HSBP provides an Atmel* 24C02 or equivalent serial EEPROM for storing the FRU information. The 24C02 EEPROM provides 2048 bits of serial electrically erasable and programmable read-only memory.

The serial EEPROM has an I²C address of 0xA6h and resides on Port 1 of the GEM424 controller.

4.3.3.4 General Purpose Input/Output (GPIO)

The GEM424 controller supports GPIO pins that are customizable. The following table lists the GPIO pins with their assigned functions.

Table 114. GEM424* Controller GPIO Assignment

GEM424 PIN NAME	I/O Type	Power Well	Programming Description	System Function	Reset State	Initial Value	Connection
GPIO0	O	3.3V	HDD0 Active LED	HD0_ACT_LED			Pull up 4.7K to 5V
GPIO1	O	3.3V	HDD1 Active LED	HD1_ACT_LED			Pull up 4.7K to 5V
GPIO2	O	3.3V	HDD2 Active LED	HD2_ACT_LED			Pull up 4.7K to 5V
GPIO3	O	3.3V	HDD3 Active LED	HD3_ACT_LED			Pull up 4.7K to 5V
GPIO4	O	3.3V	HDD4 Active LED	HD4_ACT_LED			Pull up 4.7K to 5V
GPIO5	O	3.3V	HDD5 Active LED	HD5_ACT_LED			Pull up 4.7K to 5V
GPIO6	O	3.3V	SATA HDD0 Status LED	HD0_FLT_LED_L			Pull up 4.7K to 5V
GPIO7	O	3.3V	SATA HDD1 Status LED	HD1_FLT_LED_L			Pull up 4.7K to 5V
GPIO8	O	3.3V	SATA HDD2 Status LED	HD2_FLT_LED_L			Pull up 4.7K to 5V
GPIO9	O	3.3V	SATA HDD3 Status LED	HD3_FLT_LED_L			Pull up 4.7K to 5V
GPIO10	O	3.3V	SATA HDD4 Status LED	HD4_FLT_LED_L			Pull up 4.7K to 5V
GPIO11	O	3.3V	SATA HDD5 Status LED	HD5_FLT_LED_L			Pull up 4.7K to 5V
GPIO12	I	3.3V	SATA HDD0 present detection	HD0_INSTALL_L			
GPIO13	I	3.3V	SATA HDD1 present detection	HD1_INSTALL_L			
GPIO14	I	3.3V	SATA HDD2 present detection	HD2_INSTALL_L			

GPIO15	I	3.3V	SATA HDD3 present detection	HD3_INSTALL_L			
GPIO16	I	3.3V	SATA HDD4 present detection	HD4_INSTALL_L			
GPIO17	I	3.3V	SATA HDD5 present detection	HD5_INSTALL_L			
GPIO18	O	3.3V	GPIO18				Pull up 4.7K to 5V
GPIO19	I	3.3V	FORCE UPDATE	FROCE_UPDATE_L			Pull up 4.7K to 5V
GPIO20	I	3.3V	I ² C Address control	I2C_ADDR_CNRL			Pull up 4.7K to 5V
GPIO21	O	3.3V	GPIO21				Pull up 4.7K to 5V
GPIO22	O	3.3V	GPIO22				Pull up 4.7K to 5V
GPIO23	O	3.3V	GPIO23				Pull up 4.7K to 5V

4.3.3.5 External Memory Device

The 6HDD SATA HSBP contains non-volatile 32K and 64K Serial EEPROM devices for Boot and Run-Time/Configuration code storage, respectively. These devices reside on the private I²C bus of the GEM424 controller.

The SEEPROMs operate off the 5.0V rail and are housed in 8-pin SOIC packages.

4.3.3.6 LEDs

The 6HDD SATA HSBP contains a green ACTIVITY LED and a yellow FAULT LED for each of the six drive connectors. The ACTIVITY LED is driven by the GEM424 or, for drives that support the feature, by the SATA hard drive itself whenever the drive is accessed. The FAULT LED is driven by the GEM424 controller whenever an error condition, as defined by the firmware, is detected.

Table 115. LED Function

Status LED	Definition
GREEN ON	HDD Activity
YELLOW ON	HDD Fail
YELLOW Blinking	Rebuild in progress

4.3.3.7 SATA Drive Connectors

The 6HDD SATA HSBP provides six 22-pin SATA connectors for hot swap drives supporting a 1.5GHz transfer rate.

The following table defines the pin-out of the 7-pin SATA Control Connector (J1-J6).

Table 116. 7-pin SATA Connector Pin-out

Connector Contact Number	Signal Name
1	GND
2	H_TXPn
3	H_TXNn
4	GND
5	H_RXNn
6	H_RXPn
7	GND

The following table defines the pin-out of the 22-pin SATA Drive Connector (J7-J12).

Table 117. 22-pin SATA Connector Pin-out

Connector Contact Number	Signal Name
1	SATA HDD Present
2	H_TXPn
3	H_TXNn
4	GND
5	H_RXNn
6	H_RXPn
7	GND
8	3.3V - NC
9	3.3V - NC

Connector Contact Number	Signal Name
10	3.3V Precharge - NC
11	GND
12	GND
13	GND
14	5V Precharge
15	5V
16	5V
17	GND
18	
19	GND
20	12V Precharge
21	12V
22	12V
G1	GND
G2	GND

4.3.3.8 Power Connectors

The 6HDD SATA HSBP provides two standard 4-pin hard drive power connectors. The following table defines the pin-out of the 4-pin Power Connectors (JP4 and JP5).

Table 118. Power Connector Pin-out

Pin	Signal
1	12V
2	GND
3	GND
4	5V

4.3.3.9 Clock Generation and Distribution

The 6HDD SATA HSBP provides one clock source. A 20-MHz oscillator provides the clock to the GEM424 controller.

4.3.3.10 IPMB Header - IPMB

The following table defines the pin-out of the 4-pin IPMB Header (J13).

Table 119. IPMB Header Pin-out

Pin	Signal Name	Description
1	I ² C Address Control	IPMI interface address selection. Primary = 0xC0, Secondary = 0xC2
2	BP_I2C_SCL	Clock
3	GND	
4	BP_I2C_SDA	Data

4.3.3.11 SATA Host I²C Header - I2C_1

The following table defines the pin-out of the 3-pin SATA Host I²C Header JP1.

Table 120. SATA Host I²C Header Pin-out

Pin	Signal Name	Description
1	BP_I2C_SDA	Data
2	GND	
3	BP_I2C_SCL	Clock

4.3.3.12 Board Layout

The following figure shows the board layout and connector placement of the SATA hot swap backplane.

Note: Secondary Side is mirrored.

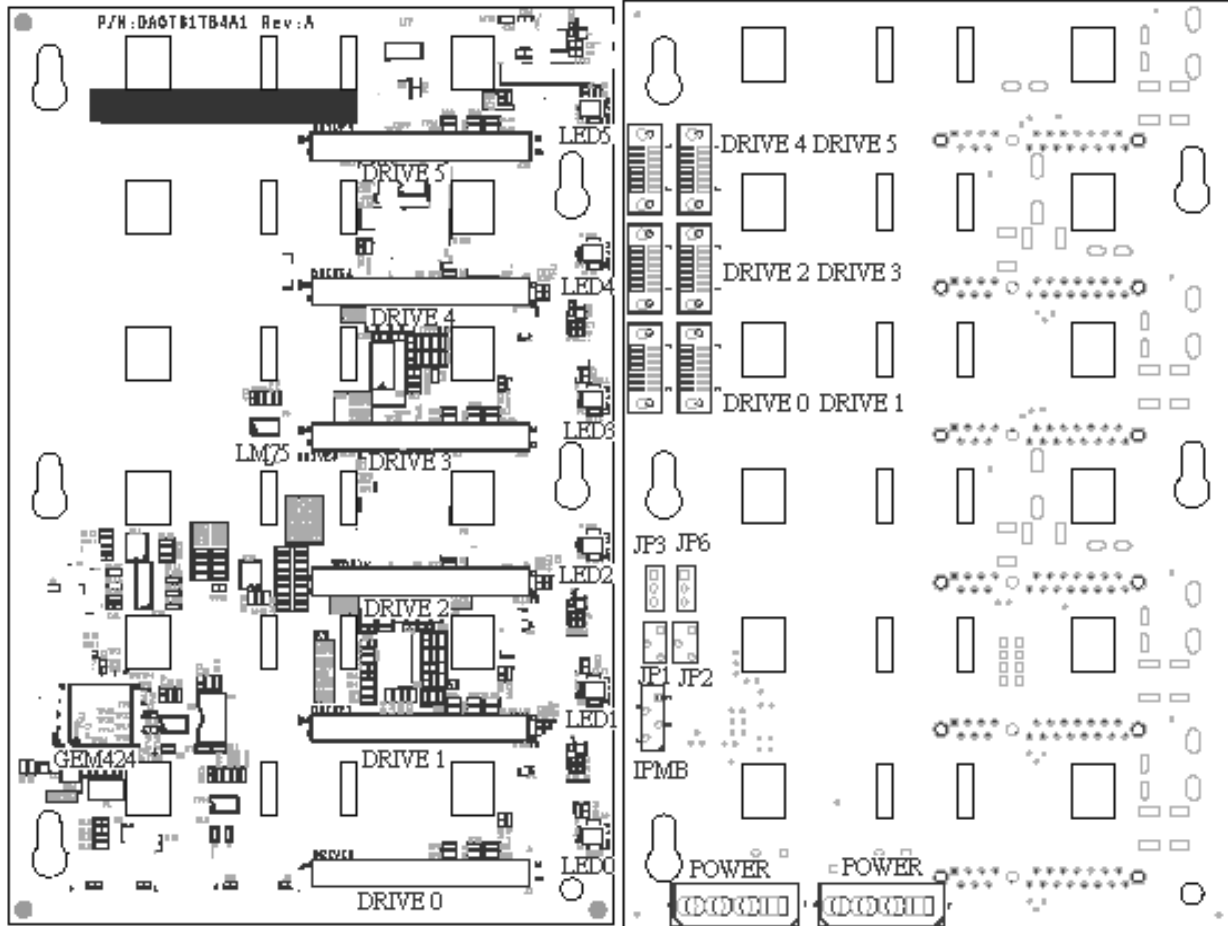

Figure 29. Intel® Entry Server Chassis SC5295-E 6HDD SATA Hot Swap Backplane Board Layout

4.3.3.13 Connector Specifications

Table 121. SATA Hot Swap Backplane Connector Specifications

Qty	Manufacturer and Part Number	Description	Reference
6	Amphenol G16A2111	SMD 7-pin SATA Control	J1 – J6
6	Foxconn LD28223-S03	THM 22-pin SATA Drive	J7 – J12
1	Molex 22-43-6040	THM 4-pin Header – IPMB J13	J13
1	Molex 22-43-6030	THM 3-pin Header – I ² C JP1, JP	JP1
2	Molex 8981-04V	THM 4-pin Connector – Power	JP4, JP5

4.3.3.14 SATA Hot Swap Drive Cage Upgrade Kit

The SATA drive cage upgrade kit allows for installation of up to six SATA drives in the server. The kit includes a SATA hot-swap drive bay with mounting hardware.

With this kit, the SATA hot swap drive cage can be directly connected to the SATA connectors on the server board for those server boards that have integrated Serial ATA, or to a Serial ATA RAID card, such as the Intel® RAID Controller SRCS14L. The RAID level that is supported depends on the feature set of the Serial ATA controller.

Kit Order Codes

AXX6SATADB

APP3HSDBKIT

5. Standard Control Panel

The Intel® Entry Server Chassis SC5295-E has two control panels available that are dependent on chassis configuration. The SC5295UP configuration has a one-button, one-LED control panel, and the SC5295DP, SC5295WS, and SC5295BRP configurations have a three-button, five-LED control panel.

When the hot-swap drive bay is installed, a bi-color hard drive LED is located on each drive carrier (six total) to indicate specific drive failure or activity. These LEDs are visible upon opening the front bezel door.

5.1 Control Panel for the SC5295UP Configuration

The UP configuration has a one-piece bezel with one button and one LED indicator, as shown in the following figure. The Entry Ebay SSI (rev 3.5) compliant control panel header for Intel® server boards is located on the back of the control panel. This allows for connection of a 34-pin ribbon cable for use with SSI rev 3.5-compliant server boards. The connector cable is compatible with the 24-pin SSI standard and is provided with the chassis kit.

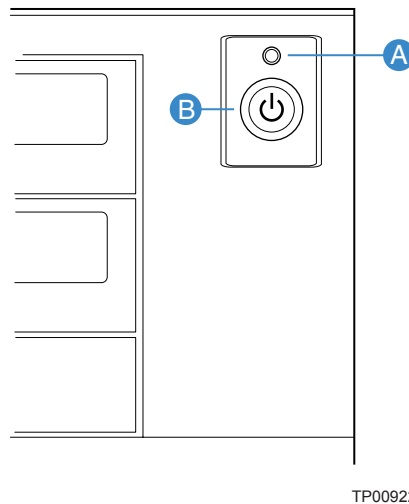

- A. Status LED
- B. Power button

Figure 30. Panel Controls and Indicators for UP Configuration

Table 122. UP Control Panel LED Functions

LED Name	Color	Condition	Description
Status LED	Green	ON	System ready (not supported by all server boards)
		BLINK	Processor or memory disabled
		OFF	Fatal error during POST

5.2 Control Panel for the SC5295DP/WS/BRP Configuration

The control panel buttons and LED indicators for the DP, WS, and BRP configurations are displayed in the following figure. The Entry Ebay SSI (rev 3.5) compliant front panel header for Intel® server boards is located on the back of the front panel. This allows for connection of a 24-pin ribbon cable for use with SSI rev 3.5-compliant server boards. The connector cable is compatible with the 24-pin SSI standard.

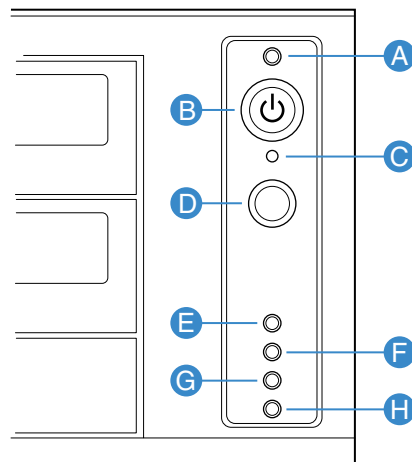

TP00872

- A. Power / Sleep LED
- B. Power button
- C. NMI button
- D. Reset Button
- E. LAN # 1 Activity LED
- F. LAN # 2 Activity LED
- G. Hard Drive Activity LED
- H. Status LED

Figure 31. Panel Controls and Indicators for DP, WS, and BRP Configurations

Table 123. Control Panel LED Functions

LED Name	Color	Condition	Description
Power/Sleep LED	Green	ON	Power on
	Amber	ON	Sleep (S1)
		OFF	Power off or Sleep (S4)
LAN # 1- Link/Activity	Green	ON	Linked
		BLINK	LAN activity
		OFF	Disconnected
LAN # 2- Link/Activity	Green	ON	Linked
		BLINK	LAN activity
		OFF	Disconnected
Hard drive activity	Green	BLINK	Hard drive activity
	Amber	ON	Fault
		OFF	No Activity
Status LED	Green	ON	System ready (not supported by all server boards)
		BLINK	Processor or memory disabled
	Amber	ON	Critical temperature or voltage fault; CPU/Terminator missing
		BLINK	Power fault; Fan fault; Non-critical temperature or voltage fault
		OFF	Fatal error during POST

Note: This is dependent on server board support. Not all server boards support all features. For additional details about control panel functions supported for a specific board, refer to the individual server board specifications.

6. Intel® Local Control Panel

The Intel® Local Control Panel (iLCP) utilizes a combination of control buttons, LEDs, and an LCD display to provide system accessibility, monitoring, and control functions, independently from the operating system. Combined with an Intel® Management Module, the iLCP allows a user to monitor the health of an Intel server platform or configure an Intel server for remote IPMI management. The control panel assembly is pre-assembled and is modular in design. The module slides into a slot on the front of the chassis and is designed so that it can be adjusted for use with or without an outer front bezel.



Figure 32. SKU3: Pedestal Server Application

Note: The Intel® Local Control Panel can only be used when either the Intel® Management Module Professional Edition or Advanced Edition is installed in the system. More information regarding the Intel® Local Control Panel can be found on the Intel support web site. The following diagram provides an overview of the control panel features.



A	LCD Display (Variable content)
B	LCD Up Navigation Button
C	LCD Down Navigation Button
D	LCD Backup Level Navigation Button
E	LCD Command Enter Button

Figure 33. Local Control Panel Components

6.1 Internal Control Panel Headers

The control panel interface board has one internal header:

- A 4-pin header provides control and status information to/from the server board via the IPMB interface. A 4-pin round cable connects the iLCP to the server board.

The following table provides the pin-out for each of these headers.

Table 124. IPMI Header

Pin #	Description
1	IPMB_5VSB_SDA
2	GND
3	IPMB_5VSB_SCL
4	P5V_STBY

7. System Interconnection

7.1 Signal Definitions

The pin-outs for the connectors referred to in this section are defined in the respective server board Technical Product Specification (TPS).

7.2 Chassis Internal Cables

7.2.1 Control Panel Cable

There are two different control panel cables based on whether the chassis is the SC5295UP version or one of the SC5295DP/WS/BRP versions. The control panel cable for the UP chassis has two twisted pair cables that terminate with a 24-pin connector. This version of the chassis features only a single button and LED. For the DP, WS, and BRP chassis, a 34-conductor ribbon cable with 34-pin IDC connectors links the control panel to the SSI EEB Revision 3.5-compliant server board.

7.2.2 USB Cable

An 8-conductor USB cable with a 10-pin server board connector and two 4-pin external USB connectors is used to connect the front mounted USB connectors to the server board.

7.2.3 Fan Connector

The installed system fan provides a 4-pin connector that is designed to mate with a SSI (ATX*)-3 and 4-pin compatible fan header.

7.2.4 Chassis Intrusion Cable

A 2-conductor chassis intrusion cable is included with the chassis kit. It connects to a 2-pin chassis intrusion header on the server board.

7.3 Server Board Internal Cables

Depending on the specific server board support for these features, some or all of the following cables may be included as part of the boxed board kit:

- IDE Cable: One or two 40-pin, 80-conductor DMA33/66/100 IDE cables.
- SCSI Cable: One 68-pin, 68-conductor twisted-pair wide SCSI cable with terminator. Cable supports connection of up to four SCSI drives to the server board.
- Floppy Cable: One 34-conductor cable featuring two 34-pin IDC connectors (2x17).
- Serial Cable: One 9-conductor cable terminated in a 2x5 header at one end and a 9-pin panel mount D sub connector on the other.
- SATA Data Cable: One or more cables with 7 contact SATA connectors. These connectors may feature a right angle or straight housing design.

7.4 Accessory Cables

7.4.1 External SCSI Cable

One 68-pin SCSI cable connects the server board or add-in SCSI card to the panel that mounts to the back of the chassis (SCSI Card Add-in cable, AXEXTSCSICBL).

7.5 I/O Panel Connectors

The Intel® Entry Server Chassis SC5295-E provides an ATX 2.2 and SSI E-bay 3.5-compliant I/O aperture for the backside I/O. The specific panel used will be provided in the boxed server board kit. The following are typical panel connections:

- PS/2 keyboard connector
- PS/2 mouse connector
- 9-pin serial port(s)
- 25-pin parallel port
- USB port(s)
- 15-pin video port
- Ethernet RJ-45 connector(s)

7.6 Spares and Accessories

Product Code	Description
APP3RACKIT	Rack mounting kit
FXX350WPSU	Replacement 350W power supply for UP
FXX450WPSU	Replacement 420W power supply for DP
FPP3BRPCAGE	Replacement 500W cage for DP
APP3500WPSU	500W module for BRP – upgrade to redundant or replacement
FPP3PMKIT	Preventative maintenance kit: <ul style="list-style-type: none"> • Plastic slide from fixed drive bay (2) • CPU duct (2 separate parts) • UP cooling duct • Intrusion switch assembly • USB cable • Front panel LED and switch cables (no PBA) • Front panel cable (for FP PBA) • Front panel board • PS adapter plate (for fixed power supply) • Power supply tool-less lock • Chassis feet • 120MM fan (3-wire thermistor type) • 120MM Fan (4-wire type) • 92MM Fan (4-wire type)
FPP3FANKIT4W	Replacement 120mm and 92mm 4-wire fans
FPP3FAN3W	Replacement 120mm 3-wire fan (WS only)
APP3HSDBKIT	Hot Swap bay mounting bracket kit (includes 2 brackets, fan shroud, and 92mm fan)

Product Code	Description
FXXPACKPPX	Replacement packaging
APP3STDBEZEL	Standard bezel (WS, DP, BRP)
FXXPP3FPBRD	Replacement front panel board

8. Supported Intel® Server Boards

The Intel® Entry Server Chassis SC5295-E is mechanically and functionally designed to support the following Intel® server boards:

- Intel® Server Board SE7320EP2
- Intel® Server Board SE7525RP2
- Intel® Server Board SE7520BD2
- Intel® Entry Server Board SE7230NH1-E

9. Regulatory, Environmental, and Specifications

9.1 Product Regulatory Compliance

WARNING

To ensure regulatory compliance, you must adhere to the assembly instructions included with this chassis to ensure and maintain compliance with existing product certifications and approvals. Use only the described, regulated components specified in this specification. Use of other products / components will void the UL listing and other regulatory approvals of the product and will most likely result in noncompliance with product regulations in the region(s) in which the product is sold.

The final configuration of your end system product may require additional EMC compliance testing. For more information please contact your local Intel Representative.

This is an FCC Class A device. Integration of it into a Class B chassis does not result in a Class B device.

This server chassis product, when correctly integrated, complies with the following safety and electromagnetic compatibility (EMC) regulations.

9.1.1 Product Safety Compliance

The Intel® Entry Server Chassis SC5295-E complies with the following safety requirements:

- UL60950 – CSA 60950(USA / Canada)
- EN60950 (Europe)
- IEC60950 (International)
- CB Certificate & Report, IEC60950 (report to include all country national deviations)
- GS License (Germany)
- GOST R 50377-92 - License (Russia)
- Belarus Licence (Belarus)
- Ukraine Licence (Ukraine)
- CE - Low Voltage Directive 73/23/EEE (Europe)
- IRAM Certification (Argentina)
- GB4943- CNCA Certification (China)

9.1.2 Product EMC Compliance – Class A Compliance

The SC5295-E has been tested and verified to comply with the following electromagnetic compatibility (EMC) regulations when configured with an Intel® compatible server board. For information on compatible server boards, refer to Intel's Server Builder website or contact your local Intel representative.

- FCC /ICES-003 - Emissions (USA/Canada) Verification
- CISPR 22 – Emissions (International)

- EN55022 - Emissions (Europe)
- EN55024 - Immunity (Europe)
- EN61000-3-2 - Harmonics (Europe)
- EN61000-3-3 - Voltage Flicker (Europe)
- CE – EMC Directive 89/336/EEC (Europe)
- VCCI Emissions (Japan)
- AS/NZS 3548 Emissions (Australia / New Zealand)
- BSMI CNS13438 Emissions (Taiwan)
- GOST R 29216-91 Emissions (Russia)
- GOST R 50628-95 Immunity (Russia)
- Belarus License (Belarus)
- Ukraine License (Ukraine)
- RRL MIC Notice No. 1997-41 (EMC) & 1997-42 (EMI) (Korea)
- GB 9254 - CNCA Certification (China)
- GB 17625 - (Harmonics) CNCA Certification (China)

9.1.3 Certifications / Registrations / Declarations

- UL Certification (US/Canada)
- CE Declaration of Conformity (CENELEC Europe)
- FCC/ICES-003 Class A Attestation (USA/Canada)
- VCCI Certification (Japan)
- C-Tick Declaration of Conformity (Australia)
- MED Declaration of Conformity (New Zealand)
- BSMI Certification (Taiwan)
- GOST R Certification / Licence (Russia)
- Belarus Certification / Licence (Belarus)
- RRL Certification (Korea)
- IRAM Certification (Argentina)
- CNCA Certification (China)
- Ecology Declaration (International)

9.1.4 Product Regulatory Compliance Markings

The Intel Server Chassis product bears the following regulatory marks.

Regulatory Compliance	Country	Marking
cULus Listing Marks	USA/Canada	
GS Mark	Germany	
CE Mark	Europe	
FCC Marking (Class A)	USA	This device complies with Part 15 of the FCC Rules. Operation of this device is subject to the following two conditions: (1) This device may not cause harmful interference, and (2) This device must accept any interference received, including interference that may cause undesired operation. Manufactured by Intel Corporation
EMC Marking (Class A)	Canada	CANADA ICES-003 CLASS A CANADA NMB-003 CLASSE A
C-Tick Mark	Australia / New Zealand	
VCCI Marking (Class A)	Japan	この装置は、クラス A 情報技術装置です。この装置を家庭環境で使用すると電波妨害を引き起こすことがあります。この場合には使用者が適切な対策を講ずるよう要求されることがあります。VCCI-A
BSMI Certification Number & Class A Warning	Taiwan	 <div style="border: 1px solid black; padding: 5px; width: fit-content;">警告使用者： 這是甲類的資訊產品，在居住的環境中使用時，可能會造成射頻干擾，在這種情況下，使用者會被要求採取某些適當的對策</div>
GOST R Marking	Russia	
RRL MIC Mark	Korea	

China Compulsory Certification Mark	China	
-------------------------------------	-------	---

9.2 Electromagnetic Compatibility Notices

9.2.1 FCC Verification Statement (USA)

This device complies with Part 15 of the FCC Rules. Operation is subject to the following two conditions: (1) This device may not cause harmful interference, and (2) this device must accept any interference received, including interference that may cause undesired operation.

Intel Corporation
5200 N.E. Elam Young Parkway
Hillsboro, OR 97124-6497
Phone: 1-800-628-8686

This equipment has been tested and found to comply with the limits for a Class A digital device, pursuant to Part 15 of the FCC Rules. These limits are designed to provide reasonable protection against harmful interference in a residential installation. This equipment generates, uses, and can radiate radio frequency energy and, if not installed and used in accordance with the instructions, may cause harmful interference to radio communications. However, there is no guarantee that interference will not occur in a particular installation. If this equipment does cause harmful interference to radio or television reception, which can be determined by turning the equipment off and on, the user is encouraged to try to correct the interference by one or more of the following measures:

- Reorient or relocate the receiving antenna.
- Increase the separation between the equipment and the receiver.
- Connect the equipment into an outlet on a circuit different from that to which the receiver is connected.
- Consult the dealer or an experienced radio/TV technician for help.

Any changes or modifications not expressly approved by the grantee of this device could void the user's authority to operate the equipment. The customer is responsible for ensuring compliance of the modified product.

Only peripherals (computer input/output devices, terminals, printers, etc.) that comply with FCC Class A or B limits may be attached to this computer product. Operation with noncompliant peripherals is likely to result in interference to radio and TV reception.

All cables used to connect to peripherals must be shielded and grounded. Operation with cables, connected to peripherals that are not shielded and grounded may result in interference to radio and TV reception.

9.2.2 ICES-003 (Canada)

Cet appareil numérique respecte les limites bruits radioélectriques applicables aux appareils numériques de Classe A prescrites dans la norme sur le matériel brouilleur: "Appareils Numériques", NMB-003 édictée par le Ministre Canadian des Communications.

(English translation of the notice above) This digital apparatus does not exceed the Class A limits for radio noise emissions from digital apparatus set out in the interference-causing equipment standard entitled "Digital Apparatus," ICES-003 of the Canadian Department of Communications.

9.2.3 Europe (CE Declaration of Conformity)

This product has been tested in accordance to, and complies with the Low Voltage Directive (73/23/EEC) and EMC Directive (89/336/EEC). The product has been marked with the CE Mark to illustrate its compliance.

9.2.4 Japan EMC Compatibility

Electromagnetic Compatibility Notices (International)

この装置は、情報処理装置等電波障害自主規制協議会（VCCI）の基準に基づくクラスA情報技術装置です。この装置を家庭環境で使用すると電波妨害を引き起こすことがあります。この場合には使用者が適切な対策を講ずるよう要求されることがあります。

English translation of the above notice:

This is a Class A product based on the standard of the Voluntary Control Council For Interference (VCCI) from Information Technology Equipment. If this is used near a radio or television receiver in a domestic environment, it may cause radio interference. Install and use the equipment according to the instruction manual.

9.2.5 BSMI (Taiwan)

The BSMI Certification number and the following warning is located on the product safety label, which is located on the bottom side (pedestal orientation) or side (rack mount configuration).

警告使用者：

這是甲類的資訊產品，在居住的環境中使用時，可能會造成射頻干擾，在這種情況下，使用者會被要求採取某些適當的對策。

9.2.6 RRL (Korea)

Following is the RRL certification information for Korea.

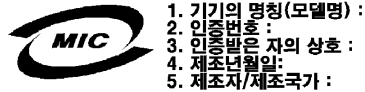

English translation of the notice above:

1. Type of Equipment (Model Name): On License and Product
2. Certification No.: On RRL certificate. Obtain certificate from local Intel representative
3. Name of Certification Recipient: Intel Corporation
4. Date of Manufacturer: Refer to date code on product
5. Manufacturer/Nation: Intel Corporation/Refer to country of origin marked on product

9.2.7 CNCA (CCC-China)

The CCC Certification Marking and EMC warning is located on the outside rear area of the product.

声明

此为A级产品，在生活环境中，该产品可能会造成无线电干扰。
 。在这种情况下，可能需要用户对其干扰采取可行的措施。

9.3 Regulated Specified Components

To maintain the UL listing and compliance to other regulatory certifications and/or declarations, the following regulated components must be used and conditions adhered to. Interchanging or use of other component will void the UL listing and other product certifications and approvals.

- **Server Chassis** - (Base chassis is provided with power supply and fans)—UL listed.
- **Server board** - Must use an Intel server board—UL recognized.
- **Add-in boards** - Must have a printed wiring board flammability rating of minimum UL94V-1. Add-in boards containing external power connectors and/or lithium batteries must be UL recognized or UL listed. Any add-in board containing modem telecommunication circuitry must be UL listed. In addition, the modem must have the appropriate telecommunications, safety, and EMC approvals for the region in which it is sold.
- **Peripheral Storage Devices** - must be UL recognized or UL listed accessory and TUV or VDE licensed. Maximum power rating of any one device is 19 watts. Total server configuration is not to exceed the maximum loading conditions of the power supply.

9.4 Replacing the Back up Battery

The lithium battery on the server board powers the real time clock (RTC) for up to 10 years in the absence of power. When the battery starts to weaken, it loses voltage, and the server settings stored in CMOS RAM in the RTC (for example, the date and time) may be wrong. Contact your customer service representative or dealer for a list of approved devices.

⚠ WARNING

Danger of explosion if battery is incorrectly replaced. Replace only with the same or equivalent type recommended by the equipment manufacturer. Discard used batteries according to manufacturer's instructions.

⚠ ADVARSEL!

Lithiumbatteri - Eksplosionsfare ved fejlagtig håndtering. Udskiftning må kun ske med batteri af samme fabrikat og type. Levér det brugte batteri tilbage til leverandøren.

⚠ ADVARSEL

Lithiumbatteri - Eksplosjonsfare. Ved utskifting benyttes kun batteri som anbefalt av apparatfabrikanten. Brukt batteri returneres apparatleverandøren.

⚠ WARNING

Explosionsfara vid felaktigt batteribyte. Använd samma batterityp eller en ekvivalent typ som rekommenderas av apparattillverkaren. Kassera använt batteri enligt fabrikantens instruktion.

⚠ VAROITUS

Paristo voi räjähtää, jos se on virheellisesti asennettu. Vaihda paristo ainoastaan laitevalmistajan suosittelemaan tyyppiin. Hävitä käytetty paristo valmistajan ohjeiden mukaisesti.

9.5 System Level Environmental Limits

The following table defines the system level operating and non-operating environmental limits (office or computer room environment).

Table 125. System Office Environment Summary

Parameter	Limits
Operating Temperature	5°C to 40°C
Non-Operating Temperature	-40°C to 70°C
Non-Operating Humidity	35°C @ 90% RH
Acoustic noise	Workstation: 4.8 idle /5.5 active BA LwA, Server: 5.5 idle/6.0 active BA LwA
Shock, operating	2g, 11 ms 1/2 Sine, 20g, 2ms, 1/2 Sine
Shock, unpackaged	25G Trapezoidal Shock
Shock, packaged	24" Free Fall, >40, <80lbs; 30" Free Fall, >20, <40lbs
Vibration, unpackaged	5Hz to 500Hz, 2.2 grms random profile
Vibration, packaged	5Hz to 500Hz, 1.09 grms random profile
ESD	2kV to 15 kV Air Discharge, 2kV to 8kV Contact Discharge

Parameter	Limits
System Cooling Requirement in BTU/Hr	

9.6 Serviceability and Availability

This system is designed to be serviced by qualified technical personnel only.

The desired Mean Time To Repair (MTTR) of the system is 30 minutes including diagnosis of the system problem. To meet this goal, the system enclosure and hardware have been designed to minimize the MTTR.

Following are the maximum times that a trained field service technician should take to perform the listed system maintenance procedures, after diagnosis of the system.

Table 126. Mean Time To Repair Estimate

Activity	Time Estimate
Remove cover	< 1 minute
Remove and replace hard disk drive	1 minute
Remove and replace 5.25-in peripheral device	1 minute
Remove and replace fixed power supply module	1 minute
Remove and replace hot swap power supply module	< 1 minute
Remove and replace drive cage fan	5 minutes
Remove and replace system fan	1 minute
Remove and replace backplane board	5 minutes
Remove and replace control panel board	5 minutes
Remove and replace server board	5 minutes

9.7 Calculated MTBF

The calculated MTBF (Mean Time Between Failures) for the Intel® Entry Server Chassis SC5295-E, as configured from the factory, is presented in the following tables.

Table 127. Intel® Entry Server Chassis SC5295-E Component MTBF

Subassembly (Server in 35 degrees C ambient air)	Server Model			
	UP, DP, WS		UP, DP, WS	
	Standard Configuration		With HSBP	
	MTBF (hours)	FIT (flrs/10 ⁹ hrs)	MTBF (hours)	FIT (flrs/10 ⁹ hrs)
Power Supply	100,000	10,000	100,000	10,000
Power Supply (non redundant with power distribution board)				
Cooling fan	500,000	2,000	500,000	2,000
Hot Swap Backplane			1,500,000	667
Front Panel Board	7,000,000	143	7,000,000	143
Intrusion Switch	25,000,000	40	25,000,000	40
Totals Chassis Assembly	82100	12,183	77900	12,850

Subassembly (Server in 35 degrees C ambient air)	Server Model			
	BRP		BRP	
	Standard Configuration		With HSBP	
	MTBF (hours)	FIT (flrs/10 ⁹ hrs)	MTBF (hours)	FIT (flrs/10 ⁹ hrs)
Power Supply				
Power Supply (non redundant with power distribution board)	90,000	11,111	90,000	11,111
Cooling fan	500,000	2,000	500,000	2,000
Hot Swap Backplane			1,500,000	667
Front Panel Board	7,000,000	143	7,000,000	143
Intrusion Switch	25,000,000	40	25,000,000	40
Totals Chassis Assembly	75300	13,294	71700	13,961

Appendix A: Integration and Usage Tips

This appendix provides a list of useful information that is unique to the Intel® Entry Server Chassis SC5295-E and should be kept in mind while integrating and configuring your server.

To maintain system thermals, fixed hard drive bays must be populated in the slots in this order: 1, 3, 5, 2, 4, 6.

To maintain system thermals, hot swap hard drive bays must be populated with either a hard drive or drive blank.

System fans are not hot swappable.

The CPU air duct(s) must be used to maintain system thermals.

The Intel® Local Control Panel can only be used with systems configured with an Intel® Management Module.

The FRUSDR utility must be run to load the proper Sensor Data Records for the Intel® Entry Server Chassis SC5295-E on the Intel® Server Board SE7520BD2.

Enter BIOS setup to select the chassis type for Intel® Server Boards SE7320EP2 and SE7525RP2.

Make sure the latest system software is loaded on the server. This includes system BIOS, FRUSDR, BMC firmware, and Hot Swap Controller firmware. The latest system software can be downloaded from:

<http://support.intel.com/support/motherboards/server/>

Glossary

Word / Acronym	Definition
ACA	Australian Communication Authority
ANSI	American National Standards Institute
ATX	Advanced Technology Extended
Auto-Ranging	Power supply that automatically senses and adjust itself to the proper input voltage range (110 VAC or 220 VAC). No manual switches or manual adjustments are needed.
BMC	Baseboard Management Controller
CFM	Cubic Feet per Minute (airflow)
CMOS	Complementary Metal Oxide Silicon
Dropout	A condition that allows the line voltage input to the power supply to drop to below the minimum operating voltage.
EEB	Entry E-Bay
EMP	Emergency Management Port
FP	Front Panel
FRB	Fault Resilient Booting
FRU	Field Replaceable Unit
HSBP	Hot Swap Backplane
Latch Off	A power supply, after detecting a fault condition, shuts itself off. Even if the fault condition disappears the supply does not restart unless manual or electronic intervention occurs. Manual intervention commonly includes briefly removing and then reconnecting the supply, or it could be done through a switch. Electronic intervention could be done by electronic signals in the Server System.
LCD	Liquid Crystal Display
LCP	Local Control Panel
LPC	Low-Pin Count
Monotonically	A waveform changes from one level to another in a steady fashion, without intermediate retrenchment or oscillation.
MTBF	Mean Time Between Failure
MTTR	Mean Time to Repair

Noise	The periodic or random signals over frequency band of 10 Hz to 20 MHz.
OTP	Over Temperature Protection
Over-current	A condition in which a supply attempts to provide more output current than the amount for which it is rated. This commonly occurs if there is a 'short circuit' condition in the load attached to the supply.
OVP	Over Voltage Protection
PDB	Power Distribution Board
PFC	Power Factor Correction
PSU	Power Supply Unit
PWOK	A typical logic level output signal provided by the supply that signals the Server System that all DC output voltages are within their specified range
RI	Ring Indicate
Ripple	The periodic or random signals over frequency band of 10 Hz to 20 MHz.
Rise Time	Rise time is defined as the time it takes any output voltage to rise from 10% to 95% of its nominal voltage.
Sag	The condition where the AC line voltage drops below the nominal voltage conditions
SCA	Single Connector Attachment
SDR	Sensor Data Record
SE	Single-Ended
SSI	Server Standards Infrastructure
Surge	The condition where the AC line voltage rises above nominal voltage.
THD	Total Harmonic Distortion
UART	Universal Asynchronous Receiver Transmitter
USB	Universal Serial Bus
VCCI	Voluntary Control Council for Interference
VSB or Stand By	An output voltage that is present whenever AC power is applied to the AC inputs of the supply.