

Intel® SC5200 Hot-Swap, Redundant Power Pedestal and Rack Server Chassis Subassembly Product Guide

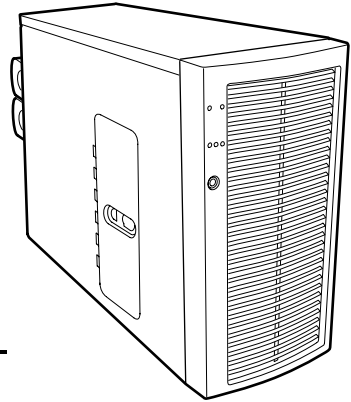

**A Guide for Technically Qualified Assemblers of Intel® Identified
Subassemblies/Products**

Order Number: A83713-002

<http://support.intel.com/support/motherboards/server/chassis/sc5200>

Disclaimer:

Information in this document is provided in connection with Intel® products. No license, express or implied, by estoppel or otherwise, to any intellectual property rights is granted by this document. Except as provided in Intel's Terms and Conditions of Sale for such products, Intel assumes no liability whatsoever, and Intel disclaims any express or implied warranty, relating to sale and/or use of Intel products including liability or warranties relating to fitness for a particular purpose, merchantability, or infringement of any patent, copyright or other intellectual property right. Intel products are not designed, intended or authorized for use in any medical, life saving, or life sustaining applications or for any other application in which the failure of the Intel product could create a situation where personal injury or death may occur. Intel may make changes to specifications and product descriptions at any time, without notice.

Intel is a registered trademark of Intel Corporation or its subsidiaries in the United States and other countries.

† Other names and brands may be claimed as the property of others.

Copyright © 2002, Intel Corporation. All rights reserved.

Contents

1 Important Safety Information

Important Safety Information	7
Intended Application Uses	7
Safety Instructions and Information	7
Checking the Power Cords	8
Multiple Power Cords.....	8
Earth Grounded Socket-Outlets.....	8
Before You Remove the Access Cover.....	9
Fans	9
Electrostatic Discharge (ESD)	9
Cooling and Airflow.....	10
Lifting and Moving.....	10
Equipment Rack Precautions.....	10
Important Set-Up Safety Information	11
WARNING: English (US)	12
AVERTISSEMENT: Français.....	14
WARNUNG: Deutsch.....	16
AVVERTENZA: Italiano	18
ADVERTENCIAS: Español	20
Backup Battery.....	22

2 Chassis Description

Kit Contents.....	23
Additions for the SC5200 Hot-Swap, Redundant Power Pedestal Chassis	23
Additions for the SC5200 Hot-Swap, Redundant Power Rack Chassis.....	23
Feature Summary.....	24
Chassis Front View.....	25
Front Panel Controls and Indicators.....	26
Chassis Rear View	28
Chassis Side View	29
Peripherals	30
5.25-inch Removable Media Drive Bays	30
5.25-inch Hard Drive Bays	30
3.5-inch Hot-Swap Drive Bay	30
Optional DLT Bracket	30
Accessories and Order Codes.....	30
Power Supply	31
Checking the Power Cords	32
Chassis Security.....	32
Monitoring.....	33
Mechanical Locks	33

3 Setting Up the Chassis

Tools and Supplies Needed.....	35
Installation Safety Instructions.....	35
Safety: Before You Remove the Access Cover.....	35
Warnings and Cautions.....	36
Install the Front Door Grill – Pedestal-mounted (Tower) Server Only.....	37
Remove the Access Cover.....	38
Remove the Plastic Air Ducts.....	39
Install the I/O Shield.....	40
Install the Server Board Bumpers.....	41
Install the Server Board.....	41
Connect Cables to the Server Board.....	42
Install the Diskette Drive.....	43
Hard Drives.....	47
Drive Cabling Considerations.....	47
Installing a 5.25-inch Removable Media Device.....	48
Installing a 5.25-inch or 3.5-inch Hard Drive.....	51
Hot-Swap SCSI Hard Disk Drives.....	54
Installing an Add-in Board.....	57
Install the Plastic Air Ducting.....	58
Install the Access Cover.....	59
Install the Chassis Feet (Pedestal Mode).....	60
Install into a Rack (Rack Mode).....	61

4 Maintaining Your Server

Tools and Supplies Needed.....	65
Safety: Before You Remove the Access Cover.....	65
Warnings and Cautions.....	65
Replacing Fans.....	66
Replacing a Front System Fan.....	67
Replacing a Rear System Fan.....	68
Replacing the Power Supply.....	69
Hot-Swapping a Power Supply.....	69
Replacing the Power Supply Housing.....	70
Replacing the Front Panel Board.....	71
Replacing the SCSI Backplane and SAF-TE Card.....	72

5 Technical Reference

Power Supply Specifications.....	77
Input Voltages.....	77
Output Voltages.....	77
System Environmental Specifications.....	78

6 Product Regulatory Compliance Information

Product Safety.....	79
Electromagnetic Compatibility (EMC) - Emissions.....	79
Electromagnetic Compatibility - Immunity.....	79

Power Line Harmonics / Voltage Flicker	79
Regional EMC Compliance Information	81
Product Ecology Documentation	83
Disposal Considerations	83

A Equipment Log and Worksheets

Equipment Log	85
Current Usage	87
Calculating Power Usage.....	87

B Warranty

Limited Warranty for Intel® Chassis Subassembly Products.....	89
Extent of Limited Warranty	89
Warranty Limitations and Exclusions	90
Limitations of Liability.....	90
How to Obtain Warranty Service	91
Telephone Support	92
Returning a Defective Product	92

Figures

1. Screw Description.....	23
2. Front View	25
3. Pedestal Controls and Indicators	26
4. Rack Controls and Indicators.....	26
5. Rear View	28
6. Chassis Side View	29
7. Power Supply	31
8. Mechanical Locks	33
9. Installing the Grill	37
10. Removing the Access Cover.....	38
11. Removing Air Ducts	39
12. Installing the I/O Shield.....	40
13. Removing the Diskette Drive Carrier.....	43
14. Installing the Diskette Drive into the Drive Carrier.....	44
15. Installing the Diskette Drive/Carrier Assembly	45
16. Routing the Floppy Drive Cable	46
17. Removing EMI Shields	48
18. Slide Rails.....	49
19. Installing a Removable Media Device	50
20. Removing a Drive Carrier	51
21. Attaching a Hard Drive to a Carrier	52
22. Installing a Carrier	53
23. Removing the Air Baffle from the Drive Carrier	54
24. SCA Hard Disk Drive and Hot-Swap Drive Carrier	55
25. Inserting a Hot-Swap Drive	56
26. Installing an Add-in Board.....	57
27. Installing Processor Area Air Duct	58
28. Installing PCI Slot Area Air Duct	59

29.	Installing the Access Cover	59
30.	Installing the Chassis Feet.....	60
31.	Attaching the Rail to the Chassis	61
32.	Rails Installed in a Rack	62
33.	Installing the Server into a Rack	63
34.	Replacing a Front System Fan	67
35.	Replacing a Rear System Fan	68
36.	Hot-Swapping a Power Supply	69
37.	Replacing the Power Supply Module	70
38.	Replacing the Front Panel Board.....	71
39.	Removing the Hot-Swap Drive Carriers	72
40.	Removing the Hot-Swap Drive Bay.....	73
41.	Removing the Hot-Swap Backplane	74
42.	Replacing the Hot-Swap Backplane.....	75
43.	SAF-TE Card and Hot-Swap Backplane	76

Tables

1.	Safety Symbols.....	7
2.	Feature Summary.....	24
3.	LED Description.....	27
4.	Accessories and Order Codes	30
5.	Redundancy LED Description	31
6.	Power Module LED Description	32
7.	Power Supply System Output Capability	77
8.	Environmental Specifications	78
9.	Product Regulatory Compliance Markings	80
10.	Regional EMC Compliance Information	81
11.	Power Usage Worksheet 1	87
12.	Power Usage Worksheet 2	88

1 Important Safety Information

Important Safety Information

Only a technically qualified person shall access, integrate, configure, and service this product.







Intended Application Uses

This product was evaluated as Information Technology Equipment (ITE), which may be installed in offices, schools, computer rooms, and similar commercial type locations. The suitability of this product for other Product Categories and Environments (such as medical, industrial, alarm systems, and test equipment), other than an ITE application, may require further evaluation.

Safety Instructions and Information

To avoid personal injury or property damage, before you begin installing the product, read, observe, and adhere to all of the following safety instructions and information. The following safety symbols may be used throughout this product guide, and may be marked on the product and or its packaging.

Table 1. Safety Symbols

CAUTION	Indicates the presence of a hazard that may cause minor personal injury or property damage if the CAUTION is ignored.
WARNING	Indicates the presence of a hazard that may result in serious injury or death if the WARNING is ignored.
	Indicates potential hazard if hazard symbol is ignored.
	Indicates shock hazards that result in serious injury or death if safety instructions are not followed.
	Indicates hot components or surfaces.
	Indicates do not touch fan blades, may result in injury.
	Indicates product has multiple power cords, and all power cords must be unplugged to disconnect AC power or mains.
	Indicates ESD sensitive components. Use of an antistatic wrist strap connected to ground is recommended.

Checking the Power Cords

WARNING

To avoid electrical shock, check the power cords as follows:

- Do not attempt to modify or use the supplied AC power cord(s), if they are not the exact type required.
- If a power cord(s) supplied is not compatible with the AC wall outlet in your region, get one that meets the following criteria:
 - The power cord must be properly rated for the AC voltage in your region.
 - The power cord plug cap must have an electrical current rating that is at least 125% of the electrical current rating of the product.
 - The power cord plug cap that plugs into the wall socket-outlet must have a grounding-type male plug designed for use in your region.
 - The power cord must have safety certifications for your region, and shall be marked with the certification markings.
 - The power cord plug cap that plugs into the AC receptacle on the power supply must be an IEC 320, sheet C13, type female connector.
 - In Europe, the power cord must be less than 4.5 meters (14.76 feet) long, and it must be flexible <HAR> (harmonized) or VDE certified cordage to comply with the chassis' safety certifications.
 - The power supply cord(s) is the main disconnect device to AC power. The socket outlet(s) shall be near the equipment and shall be readily accessible for disconnection.

Multiple Power Cords



WARNING

To avoid electrical shock, disconnect all AC power cords before accessing inside the system.

Earth Grounded Socket-Outlets

WARNING

To avoid electrical shock, the system power cord(s) must be plugged into socket-outlet(s) that is provided with a suitable earth ground. The system will be provided with the following marking:

Connect only to properly earthed socket outlet.

Apparaten skall anslutas till jordat uttag när den ansluts till ett nätverk.

Before You Remove the Access Cover

WARNING

To avoid personal injury or property damage, the following safety instructions apply whenever accessing inside the product:

- Turn off all peripheral devices connected to this product.
- Turn off the system by pressing the power button on the front of the product.
- Disconnect the AC power by unplugging all AC power cords from the system or wall outlet.
- Disconnect all cables and telecommunication lines that are connected to the system.
- Retain all screws or other fasteners when removing access cover(s). Upon completion of accessing inside the product, refasten access cover with original screws or fasteners.
- Do not access inside power supply. There are no serviceable parts in the power supply. Return to manufacturer for servicing.

Fans

CAUTION

To avoid injury do not contact moving fan blades.

Electrostatic Discharge (ESD)

CAUTION

Perform the procedures in this chapter only at an electrostatic discharge (ESD) workstation, because the server components can be extremely sensitive to ESD. If no such station is available, you can reduce the risk of electrostatic discharge ESD damage by doing the following:

- Wear an antistatic wrist strap and attach it to a metal part of the server.
- Touch the metal on the server chassis before touching the server components.
- Keep part of your body in contact with the metal server chassis to dissipate the static charge while handling the components.
- Avoid moving around unnecessarily.
- Hold the server components (especially boards) only by the edges.
- Place the server components on a grounded, static-free surface. Use a conductive foam pad if available but not the component wrapper.

Do not slide the components over any surface.

Cooling and Airflow

CAUTION

For proper cooling and airflow, always install all access covers before turning on the system. Operating the system for longer than five minutes without the covers in place can cause overheating and damage to system components.

Lifting and Moving

CAUTION

Do not attempt to lift or move the server by the handles on the power supplies.

Equipment Rack Precautions

Follow the rack manufacturer's safety and installation instructions for proper rack installation. The following additional rack safety installation measures shall be considered:

ANCHOR THE EQUIPMENT RACK

The equipment rack must be anchored to an unmovable suitable support to prevent the rack from falling over when one or more systems are fully extended out of the rack assembly. You must also consider the weight of any other devices installed in the rack assembly. The equipment rack must be installed according to the manufacturer's instructions.

MAIN AC POWER DISCONNECT

You are responsible for installing an AC power disconnect for the entire rack unit. This main disconnect must be readily accessible, and it must be labeled as controlling power to the entire unit, not just to the system(s).

GROUNDING THE RACK INSTALLATION

To avoid the potential for an electrical shock hazard, the rack assembly itself must be suitably earth grounded, according to your local regional electrical codes. This typically will require the rack to have its own separate earth ground. We recommend you consult your local approved electrician.



OVER CURRENT PROTECTION

The system is designed to operate on a 20 A AC voltage source that is provided with 20 A over current protection. If the AC source for the rack exceeds 20 A over current protection, each system must be provided with 20 A or less over current supplemental protection. The supplementary over current protection must have the appropriate regional safety certifications for the over current application.



TEMPERATURE LIMITS

The operating temperature of the system, when installed in the rack, must not go below 5 °C (41 °F) or rise above 35 °C (95 °F). Extreme fluctuations in temperature may cause a variety of problems in system, and safety limits may be broken.



VENTILATION CONSIDERATIONS

The equipment rack must provide sufficient airflow to the front of the system to maintain proper cooling. The rack selected and the ventilation provided must be suitable to the environment in which the system will be used.

Important Set-Up Safety Information

WARNING: ENGLISH (US)

AVERTISSEMENT: FRANÇAIS

WARNUNG: DEUTSCH

AVVERTENZA: ITALIANO

ADVERTENCIAS: ESPAÑOL

WARNING: English (US)

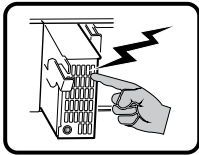

The power supply in this product contains no user-serviceable parts. There may be more than one supply in this product. Refer servicing only to qualified personnel.

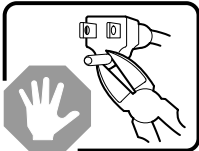

Do not attempt to modify or use the supplied AC power cord if it is not the exact type required. A product with more than one power supply will have a separate AC power cord for each supply.

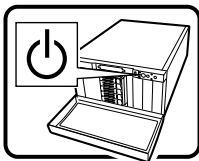

The power button on the system does not turn off system AC power. To remove AC power from the system, you must unplug each AC power cord from the wall outlet or power supply.

The power cord(s) is considered the disconnect device to the mains (AC) power. The socket outlet that the system plugs into shall be installed near the equipment and shall be easily accessible.

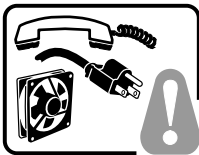

SAFETY STEPS: Whenever you remove the chassis covers to access the inside of the system, follow these steps:

1. Turn off all peripheral devices connected to the system.
2. Turn off the system by pressing the power button.
3. Unplug all AC power cords from the system or from wall outlets.
4. Label and disconnect all cables connected to I/O connectors or ports on the back of the system.
5. Provide some electrostatic discharge (ESD) protection by wearing an antistatic wrist strap attached to chassis ground of the system—any unpainted metal surface—when handling components.
6. Do not operate the system with the chassis covers removed.

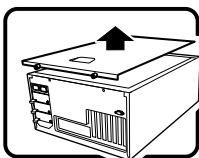

After you have completed the six SAFETY steps above, you can remove the system covers. To do this:

1. Unlock and remove the padlock from the back of the system if a padlock has been installed.
2. Remove and save all screws from the covers.
3. Remove the covers.

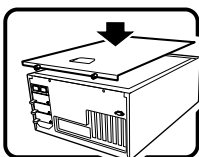

For proper cooling and airflow, always reinstall the chassis covers before turning on the system. Operating the system without the covers in place can damage system parts. To install the covers:

1. Check first to make sure you have not left loose tools or parts inside the system.
 2. Check that cables, add-in boards, and other components are properly installed.
 3. Attach the covers to the chassis with the screws removed earlier, and tighten them firmly.
 4. Insert and lock the padlock to the system to prevent unauthorized access inside the system.
 5. Connect all external cables and the AC power cord(s) to the system.
-

continued

WARNING: English (continued)

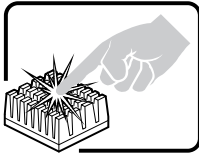

A microprocessor and heat sink may be hot if the system has been running. Also, there may be sharp pins and edges on some board and chassis parts. Contact should be made with care. Consider wearing protective gloves.

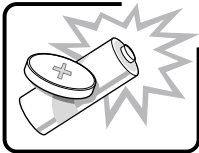

Danger of explosion if the battery is incorrectly replaced. Replace only with the same or equivalent type recommended by the equipment manufacturer. Dispose of used batteries according to manufacturer's instructions.

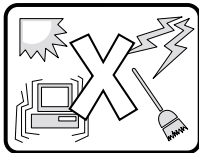

The system is designed to operate in a typical office environment. Choose a site that is:

- Clean and free of airborne particles (other than normal room dust).
 - Well ventilated and away from sources of heat including direct sunlight.
 - Away from sources of vibration or physical shock.
 - Isolated from strong electromagnetic fields produced by electrical devices.
 - In regions that are susceptible to electrical storms, we recommend you plug your system into a surge suppresser and disconnect telecommunication lines to your modem during an electrical storm.
 - Provided with a properly grounded wall outlet.
 - Provided with sufficient space to access the power supply cords, because they serve as the product's main power disconnect.
-

AVERTISSEMENT: Français

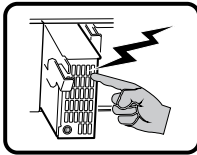

Le bloc d'alimentation de ce produit ne contient aucune pièce pouvant être réparée par l'utilisateur. Ce produit peut contenir plus d'un bloc d'alimentation. Veuillez contacter un technicien qualifié en cas de problème.

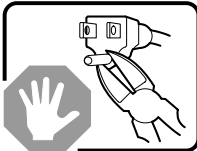

Ne pas essayer d'utiliser ni modifier le câble d'alimentation CA fourni, s'il ne correspond pas exactement au type requis. Le nombre de câbles d'alimentation CA fournis correspond au nombre de blocs d'alimentation du produit.

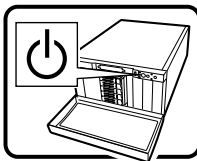

Notez que le commutateur CC de mise sous tension /hors tension du panneau avant n'éteint pas l'alimentation CA du système. Pour mettre le système hors tension, vous devez débrancher chaque câble d'alimentation de sa prise.



CONSIGNES DE SÉCURITÉ - Lorsque vous ouvrez le boîtier pour accéder à l'intérieur du système, suivez les consignes suivantes :

1. Mettez hors tension tous les périphériques connectés au système.
2. Mettez le système hors tension en mettant l'interrupteur général en position OFF (bouton-poussoir).
3. Débranchez tous les cordons d'alimentation c.a. du système et des prises murales.
4. Identifiez et débranchez tous les câbles reliés aux connecteurs d'E-S ou aux accès derrière le système.
5. Pour prévenir les décharges électrostatiques lorsque vous touchez aux composants, portez une bande antistatique pour poignet et reliez-la à la masse du système (toute surface métallique non peinte du boîtier).
6. Ne faites pas fonctionner le système tandis que le boîtier est ouvert.

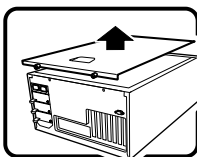

Une fois TOUTES les étapes précédentes accomplies, vous pouvez retirer les panneaux du système. Procédez comme suit :

1. Si un cadenas a été installé sur à l'arrière du système, déverrouillez-le et retirez-le.
2. Retirez toutes les vis des panneaux et mettez-les dans un endroit sûr.
3. Retirez les panneaux.

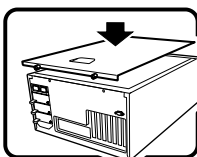

Afin de permettre le refroidissement et l'aération du système, réinstallez toujours les panneaux du boîtier avant de mettre le système sous tension. Le fonctionnement du système en l'absence des panneaux risque d'endommager ses pièces. Pour installer les panneaux, procédez comme suit :

1. Assurez-vous de ne pas avoir oublié d'outils ou de pièces démontées dans le système.
2. Assurez-vous que les câbles, les cartes d'extension et les autres composants sont bien installés.
3. Revissez solidement les panneaux du boîtier avec les vis retirées plus tôt.
4. Remettez le cadenas en place et verrouillez-le afin de prévenir tout accès non autorisé à l'intérieur du système.
5. Rebranchez tous les cordons d'alimentation c. a. et câbles externes au système.

Suite

AVERTISSEMENT: Français (suite)

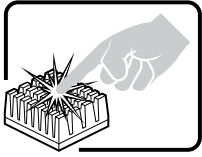

Le microprocesseur et le dissipateur de chaleur peuvent être chauds si le système a été sous tension. Faites également attention aux broches aiguës des cartes et aux bords tranchants du capot. Nous vous recommandons l'usage de gants de protection.

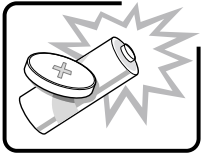

Danger d'explosion si la batterie n'est pas remontée correctement. Remplacer uniquement avec une batterie du même type ou d'un type équivalent recommandé par le fabricant. Disposez des piles usées selon les instructions du fabricant.

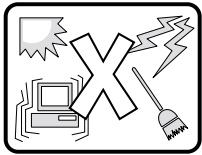

Le système a été conçu pour fonctionner dans un cadre de travail normal. L'emplacement choisi doit être:

- Propre et dépourvu de poussière en suspension (sauf la poussière normale).
 - Bien aéré et loin des sources de chaleur, y compris du soleil direct.
 - A l'abri des chocs et des sources de vibrations.
 - Isolé de forts champs électromagnétiques géénérés par des appareils électriques.
 - Dans les régions sujettes aux orages magnétiques il est recomandé de brancher votre système à un supresseur de surtension, et de débrancher toutes les lignes de télécommunications de votre modem durant un orage.
 - Muni d'une prise murale correctement mise à la terre.
 - Suffisamment spacieux pour vous permettre d'accéder aux câbles d'alimentation (ceux-ci étant le seul moyen de mettre le système hors tension).
-

WARNUNG: Deutsch

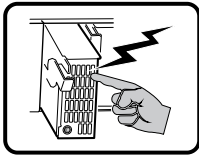

Benutzer können am Netzgerät dieses Produkts keine Reparaturen vornehmen. Das Produkt enthält möglicherweise mehrere Netzgeräte. Wartungsarbeiten müssen von qualifizierten Technikern ausgeführt werden.

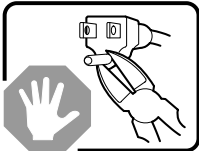

Versuchen Sie nicht, das mitgelieferte Netzkabel zu ändern oder zu verwenden, wenn es sich nicht genau um den erforderlichen Typ handelt. Ein Produkt mit mehreren Netzgeräten hat für jedes Netzgerät ein eigenes Netzkabel.

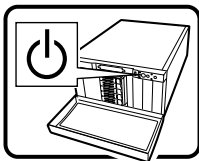

Der Wechselstrom des Systems wird durch den Ein-/Aus-Schalter für Gleichstrom nicht ausgeschaltet. Ziehen Sie jedes Wechselstrom-Netzkabel aus der Steckdose bzw. dem Netzgerät, um den Stromanschluß des Systems zu unterbrechen.

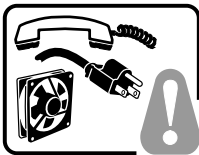

SICHERHEISSCHRIFFEN: Immer wenn Sie die Gehäuseabdeckung abnehmen um an das Systeminnere zu gelangen, sollten Sie folgende Schritte beachten:

1. Schalten Sie alle an Ihr System angeschlossenen Peripheriegeräte aus.
2. Schalten Sie das System mit dem Hauptschalter aus.
3. Ziehen Sie den Stromanschlußstecker Ihres Systems aus der Steckdose.
4. Auf der Rückseite des Systems beschriften und ziehen Sie alle Anschlußkabel von den I/O Anschlüssen oder Ports ab.
5. Tragen Sie ein geerdetes Antistatik Gelenkband, um elektrostatische Ladungen (ESD) über blanke Metallstellen bei der Handhabung der Komponenten zu vermeiden.
6. Schalten Sie das System niemals ohne ordnungsgemäß montiertes Gehäuse ein.

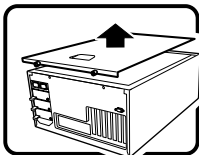

Nachdem Sie die oben erwähnten ersten sechs SICHERHEITSSCHRITTE durchgeführt haben, können Sie die Abdeckung abnehmen, indem Sie:

1. Öffnen und entfernen Sie die Verschlusseinrichtung (Padlock) auf der Rückseite des Systems, falls eine Verschlusseinrichtung installiert ist.
2. Entfernen Sie alle Schrauben der Gehäuseabdeckung.
3. Nehmen Sie die Abdeckung ab.

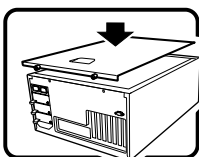

Zur ordnungsgemäßen Kühlung und Lüftung muß die Gehäuseabdeckung immer wieder vor dem Einschalten installiert werden. Ein Betrieb des Systems ohne angebrachte Abdeckung kann Ihrem System oder Teile darin beschädigen. Um die Abdeckung wieder anzubringen:

1. Vergewissern Sie sich, daß Sie keine Werkzeuge oder Teile im Innern des Systems zurückgelassen haben.
2. Überprüfen Sie alle Kabel, Zusatzkarten und andere Komponenten auf ordnungsgemäßen Sitz und Installation.
3. Bringen Sie die Abdeckungen wieder am Gehäuse an, indem Sie die zuvor gelösten Schrauben wieder anbringen. Ziehen Sie diese gut an.
4. Bringen Sie die Verschlusseinrichtung (Padlock) wieder an und schließen Sie diese, um ein unerlaubtes Öffnen des Systems zu verhindern.
5. Schließen Sie alle externen Kabel und den AC Stromanschlußstecker Ihres Systems wieder an.

Fortsetzung

WARNUNG: Deutsch (Fortsetzung)

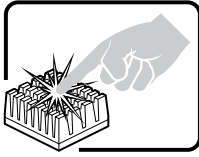

Der Mikroprozessor und der Kühler sind möglicherweise erhitzt, wenn das System in Betrieb ist. Außerdem können einige Platinen und Gehäuseteile scharfe Spitzen und Kanten aufweisen. Arbeiten an Platinen und Gehäuse sollten vorsichtig ausgeführt werden. Sie sollten Schutzhandschuhe tragen.

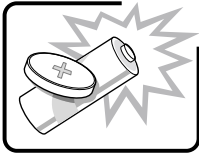

Bei falschem Einsetzen einer neuen Batterie besteht Explosionsgefahr. Die Batterie darf nur durch denselben oder einen entsprechenden, vom Hersteller empfohlenen Batterietyp ersetzt werden. Entsorgen Sie verbrauchte Batterien den Anweisungen des Herstellers entsprechend.

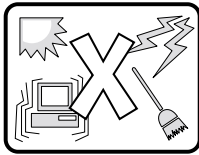

Das System wurde für den Betrieb in einer normalen Büroumgebung entwickelt. Der Standort sollte:

- sauber und staubfrei sein (Hausstaub ausgenommen);
 - gut gelüftet und keinen Heizquellen ausgesetzt sein (einschließlich direkter Sonneneinstrahlung);
 - keinen Erschütterungen ausgesetzt sein;
 - keine starken, von elektrischen Geräten erzeugten elektromagnetischen Felder aufweisen;
 - in Regionen, in denen elektrische Stürme auftreten, mit einem Überspannungsschutzgerät verbunden sein; während eines elektrischen Sturms sollte keine Verbindung der Telekommunikationsleitungen mit dem Modem bestehen;
 - mit einer geerdeten Wechselstromsteckdose ausgerüstet sein;
 - über ausreichend Platz verfügen, um Zugang zu den Netzkabeln zu gewährleisten, da der Stromanschluß des Produkts hauptsächlich über die Kabel unterbrochen wird.
-

AVVERTENZA: Italiano

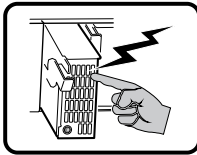

Rivolgersi ad un tecnico specializzato per la riparazione dei componenti dell'alimentazione di questo prodotto. È possibile che il prodotto disponga di più fonti di alimentazione.

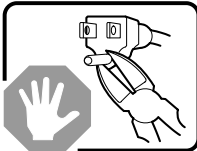

Non modificare o utilizzare il cavo di alimentazione in c.a. fornito dal produttore, se non corrisponde esattamente al tipo richiesto. Ad ogni fonte di alimentazione corrisponde un cavo di alimentazione in c.a. separato.

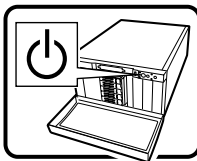

L'interruttore attivato/disattivato nel pannello anteriore non interrompe l'alimentazione in c.a. del sistema. Per interromperla, è necessario scollegare tutti i cavi di alimentazione in c.a. dalle prese a muro o dall'alimentazione di corrente.

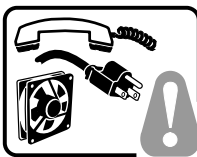

PASSI DI SICUREZZA: Qualora si rimuovano le coperture del telaio per accedere all'interno del sistema, seguire i seguenti passi:

1. Spegner tutti i dispositivi periferici collegati al sistema.
2. Spegner il sistema, usando il pulsante spento/acceso dell'interruttore del sistema.
3. Togliere tutte le spine dei cavi del sistema dalle prese elettriche.
4. Identificare e sconnettere tutti i cavi attaccati ai collegamenti I/O od alle prese installate sul retro del sistema.
5. Qualora si tocchino i componenti, proteggersi dallo scarico elettrostatico (SES), portando un cinghia anti-statica da polso che è attaccata alla presa a terra del telaio del sistema – qualsiasi superficie non dipinta – .
6. Non far operare il sistema quando il telaio è senza le coperture.

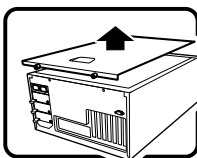

Dopo aver seguito i sei passi di SICUREZZA sopracitati, togliere le coperture del telaio del sistema come segue:

1. Aprire e rimuovere il lucchetto dal retro del sistema qualora ve ne fosse uno installato.
2. Togliere e mettere in un posto sicuro tutte le viti delle coperture.
3. Togliere le coperture.

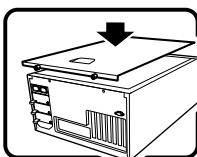

Per il giusto flusso dell'aria e raffreddamento del sistema, rimettere sempre le coperture del telaio prima di riaccendere il sistema. Operare il sistema senza le coperture al loro proprio posto potrebbe danneggiare i componenti del sistema. Per rimettere le coperture del telaio:

1. Controllare prima che non si siano lasciati degli attrezzi o dei componenti dentro il sistema.
2. Controllare che i cavi, dei supporti aggiuntivi ed altri componenti siano stati installati appropriatamente.
3. Attaccare le coperture al telaio con le viti tolte in precedenza e avvitarle strettamente.
4. Inserire e chiudere a chiave il lucchetto sul retro del sistema per impedire l'accesso non autorizzato al sistema.
5. Ricollegare tutti i cavi esterni e le prolunghe AC del sistema.

Continua

AVVERTENZA: Italiano (continua)

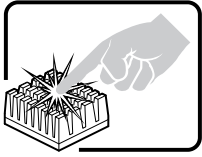

Se il sistema è stato a lungo in funzione, il microprocessore e il dissipatore di calore potrebbero essere surriscaldati. Fare attenzione alla presenza di piedini appuntiti e parti taglienti sulle schede e sul telaio. È consigliabile l'uso di guanti di protezione.

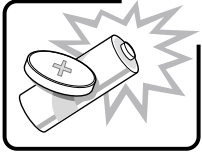

Esiste il pericolo di un'esplosione se la pila non viene sostituita in modo corretto. Utilizzare solo pile uguali o di tipo equivalente a quelle consigliate dal produttore. Per disfarsi delle pile usate, seguire le istruzioni del produttore.

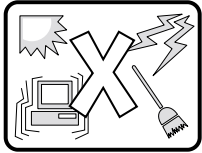

Il sistema è progettato per funzionare in un ambiente di lavoro tipo. Scegliere una postazione che sia:

- Pulita e libera da particelle in sospensione (a parte la normale polvere presente nell'ambiente).
 - Ben ventilata e lontana da fonti di calore, compresa la luce solare diretta.
 - Al riparo da urti e lontana da fonti di vibrazione.
 - Isolata dai forti campi magnetici prodotti da dispositivi elettrici.
 - In aree soggette a temporali, è consigliabile collegare il sistema ad un limitatore di corrente. In caso di temporali, scollegare le linee di comunicazione dal modem.
 - Dotata di una presa a muro correttamente installata.
 - Dotata di spazio sufficiente ad accedere ai cavi di alimentazione, i quali rappresentano il mezzo principale di scollegamento del sistema.
-

ADVERTENCIAS: Español

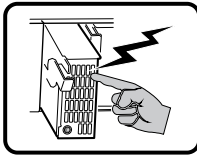

El usuario debe abstenerse de manipular los componentes de la fuente de alimentación de este producto, cuya reparación debe dejarse exclusivamente en manos de personal técnico especializado. Puede que este producto disponga de más de una fuente de alimentación.

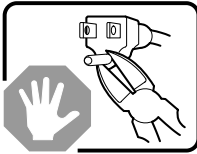

No intente modificar ni usar el cable de alimentación de corriente alterna, si no corresponde exactamente con el tipo requerido.

El número de cables suministrados se corresponden con el número de fuentes de alimentación de corriente alterna que tenga el producto.

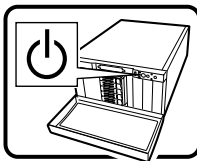

Nótese que el interruptor activado/desactivado en el panel frontal no desconecta la corriente alterna del sistema. Para desconectarla, deberá desenchufar todos los cables de corriente alterna de la pared o desconectar la fuente de alimentación.

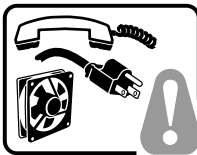

INSTRUCCIONES DE SEGURIDAD: Cuando extraiga la tapa del chasis para acceder al interior del sistema, siga las siguientes instrucciones:

1. Apague todos los dispositivos periféricos conectados al sistema.
2. Apague el sistema presionando el interruptor encendido/apagado.
3. Desconecte todos los cables de alimentación CA del sistema o de las tomas de corriente alterna.
4. Identifique y desconecte todos los cables enchufados a los conectores E/S o a los puertos situados en la parte posterior del sistema.
5. Cuando manipule los componentes, es importante protegerse contra la descarga electrostática (ESD). Puede hacerlo si utiliza una muñequera antiestática sujeta a la toma de tierra del chasis — o a cualquier tipo de superficie de metal sin pintar.
6. No ponga en marcha el sistema si se han extraído las tapas del chasis.

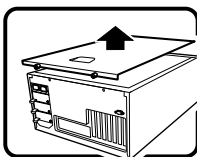

Después de completar las seis instrucciones de SEGURIDAD mencionadas, ya puede extraer las tapas del sistema. Para ello:

1. Desbloquee y extraiga el bloqueo de seguridad de la parte posterior del sistema, si se ha instalado uno.
2. Extraiga y guarde todos los tornillos de las tapas.
3. Extraiga las tapas.

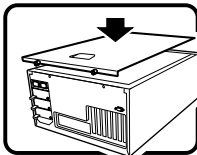

Para obtener un enfriamiento y un flujo de aire adecuados, reinstale siempre las tapas del chasis antes de poner en marcha el sistema. Si pone en funcionamiento el sistema sin las tapas bien colocadas puede dañar los componentes del sistema. Para instalar las tapas:

1. Asegúrese primero de no haber dejado herramientas o componentes sueltos dentro del sistema.
2. Compruebe que los cables, las placas adicionales y otros componentes se hayan instalado correctamente.
3. Incorpore las tapas al chasis mediante los tornillos extraídos anteriormente, tensándolos firmemente.
4. Inserte el bloqueo de seguridad en el sistema y bloquéelo para impedir que pueda accederse al mismo sin autorización.
5. Conecte todos los cables externos y los cables de alimentación CA al sistema.

Continúa

ADVERTENCIAS: Español (continúa)

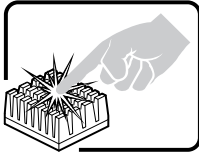

Si el sistema ha estado en funcionamiento, el microprocesador y el disipador de calor pueden estar aún calientes. También conviene tener en cuenta que en el chasis o en el tablero puede haber piezas cortantes o punzantes. Por ello, se recomienda precaución y el uso de guantes protectores.

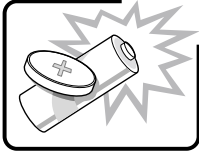

Existe peligro de explosión si la pila no se cambia de forma adecuada. Utilice solamente pilas iguales o del mismo tipo que las recomendadas por el fabricante del equipo. Para deshacerse de las pilas usadas, siga igualmente las instrucciones del fabricante.

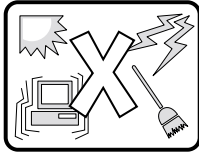

El sistema está diseñado para funcionar en un entorno de trabajo normal. escoja un lugar:

- Limpio y libre de partículas en suspensión (salvo el polvo normal).
 - Bien ventilado y alejado de fuentes de calor, incluida la luz solar directa.
 - Alejado de fuentes de vibración.
 - Aislado de campos electromagnéticos fuertes producidos por dispositivos eléctricos.
 - En regiones con frecuentes tormentas eléctricas, se recomienda conectar su sistema a un eliminador de sobrevoltage y desconectar el módem de las líneas de telecomunicación durante las tormentas.
 - Provisto de una toma de tierra correctamente instalada.
 - Provisto de espacio suficiente como para acceder a los cables de alimentación, ya que éstos hacen de medio principal de desconexión del sistema.
-

Backup Battery

The lithium battery on the baseboard powers the real-time clock (RTC) for up to 10 years in the absence of power. When the battery starts to weaken, it loses voltage, and the server settings stored in CMOS RAM in the RTC (for example, the date and time) might be incorrect.

For a list of approved replacement batteries, contact your customer service representative or dealer.

WARNING!

Danger of explosion if battery is incorrectly replaced. Replace with only the same or equivalent type recommended by the manufacturer. Dispose of used batteries according to the manufacturer's instructions.

ADVARSEL!

Lithiumbatteri - Eksplosjonsfare ved fejlagtig håndtering. Udskiftning må kun ske med batteri af samme fabrikat og type. Levér det brugte batteri tilbage til leverandøren.

ADVARSEL!

Lithiumbatteri - Eksplosjonsfare. Ved utskifting benyttes kun batteri som anbefalt av apparatfabrikanten. Brukt batteri returneres apparatleverandøren.

WARNING!

Explosionsfara vid felaktigt batteribyte. Använd samma batterityp eller en ekvivalent typ som rekommenderas av apparattillverkaren. Kassera använt batteri enligt fabrikantens instruktion.

VAROITUS!

Paristo voi räjähtää, jos se on virheellisesti asennettu. Vaihda paristo ainoastaan laitevalmistajan suosittelemaan tyyppiin. Hävitä käytetty paristo valmistajan ohjeiden mukaisesti.

2 Chassis Description

Kit Contents

The chassis subassembly kit includes a documentation CD-ROM that contains this Product Guide; one power cord; and a box that includes four 5.25-inch external drive rails, a padlock loop for securing the chassis, and four different types of mounting screws.

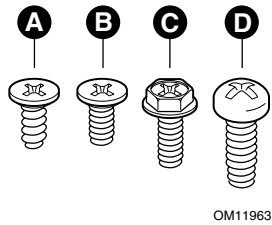

- | | |
|--------------------------------|-------------------------------|
| A. Flat head 6-32 x 5mm [.200] | C. Hex head 6-32 x 6mm [.256] |
| B. Flat head M3 x 5mm [.200] | D. Round head M4 x 8mm [.315] |

Figure 1. Screw Description

Additions for the SC5200 Hot-Swap, Redundant Power Pedestal Chassis

In addition, this kit includes two chassis feet.

Additions for the SC5200 Hot-Swap, Redundant Power Rack Chassis

In addition, this kit includes two rack-mountable rail assemblies and mounting hardware.

Feature Summary

Table 2. Feature Summary

Feature	Description
Drive Bays	One 3.5-inch diskette drive bay, accessible from front. Two 5.25-inch wide bays that are externally accessible, designed to hold half-height standard removable media devices; two of the bays can be converted into a single full-height bay. Two 5.25-inch wide bays that are not externally accessible, designed to hold half-height IDE drives. A hot-swap bay for 3.5-inch hard disk drives: space for up to five 1-inch high, SCA2 hard drives.
Expansion slot covers	Up to seven expansion slots can be used; every slot that does not have an add-in board installed must have a slot cover installed.
Power supply	650 watt hot-swap redundant 2+1 PFC power supply.
Cooling	Five hot-swap system fans: three inside the chassis and two on the rear. Two power supply fans.

Chassis Front View

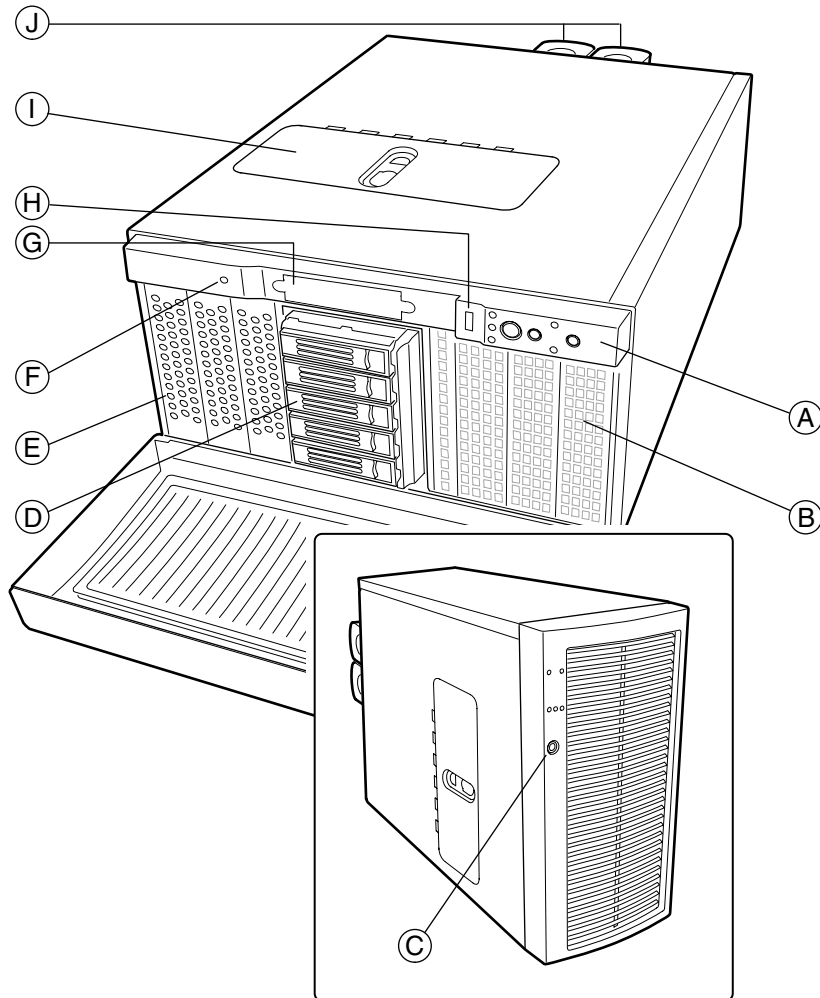

OM14010

- A. Front panel controls and indicators
- B. 5.25-inch removable media drive bays
- C. Security lock (pedestal configuration)
- D. Hot-swap drive carriers
- E. Internal drive bays
- F. Chassis intrusion switch
- G. Diskette drive bay location
- H. USB port
- I. Front hot-swap system fan access door
- J. Rear hot-swap system fans

Figure 2. Front View

Front Panel Controls and Indicators

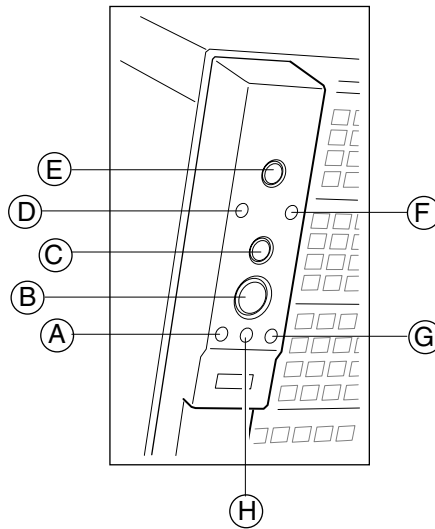

OM11954

- | | |
|----------------------------|------------------------|
| A. Hard drive activity LED | E. Reset button |
| B. Power button | F. LAN #2 activity LED |
| C. Sleep button | G. Status LED |
| D. LAN #1 activity LED | H. Power/Sleep LED |

Figure 3. Pedestal Controls and Indicators

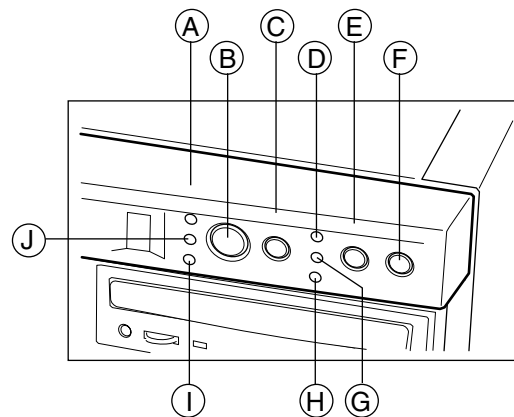

OM12035

- | | |
|----------------------------|------------------------|
| A. Hard drive activity LED | F. ID button |
| B. Power button | G. ID LED |
| C. Sleep button | H. LAN #2 activity LED |
| D. LAN #1 activity LED | I. Status LED |
| E. Reset button | J. Power/sleep LED |

Figure 4. Rack Controls and Indicators

Table 3. LED Description

LED Name	Color	Condition	Description
Hard drive activity	Green	BLINK	Hard drive activity
	Amber	ON	Fault
		OFF	No activity
LAN#1 activity	Green	ON	Linked
	Green	BLINK	LAN activity
		OFF	Disconnected
LAN#2-Link/Act	Green	ON	Linked
	Green	BLINK	LAN activity
		OFF	Disconnected
Status LED	Green	ON	System ready
	Green	BLINK	Processor or memory disabled
	Amber	ON	Temperature or voltage critical fault; CPU/Terminator missing
	Amber	BLINK	Power fault; Fan fault; Temperature or voltage non-critical fault
		OFF	Fatal error during POST
Power/Sleep LED	Green	ON	Power on
	Amber	ON	Sleep (S1)
		OFF	Power off or Sleep (S4)
ID LED (rack only)	Blue	On	Server identification; Toggled by ID button or software (rack-mount system only)
		OFF	Server identification; Toggled by ID button or software (rack-mount system only)

Chassis Rear View

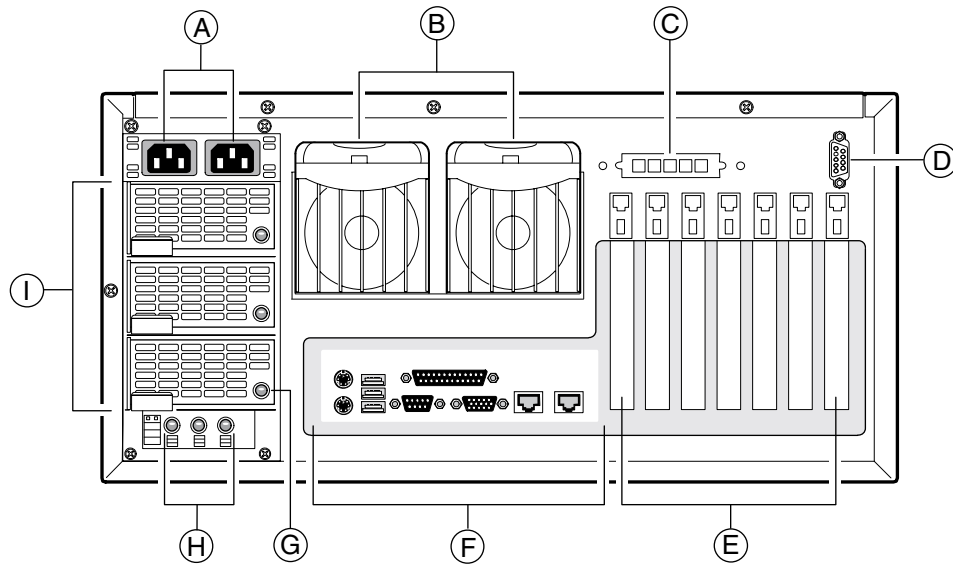

OM14011

- A. AC input power connectors
- B. Rear System Fans
- C. ICMB or external SCSI connector knockout
- D. Optional serial port*
- E. Expansion slot covers
- F. I/O ports*
- G. Power supply module status LED (Green LED means proper operation)*
- H. AC module Power Good LEDs (AC1, AC2, ACR; lit means proper operation)
- I. Power supply modules

* Items shown may differ in your chassis.

Figure 5. Rear View

Chassis Side View

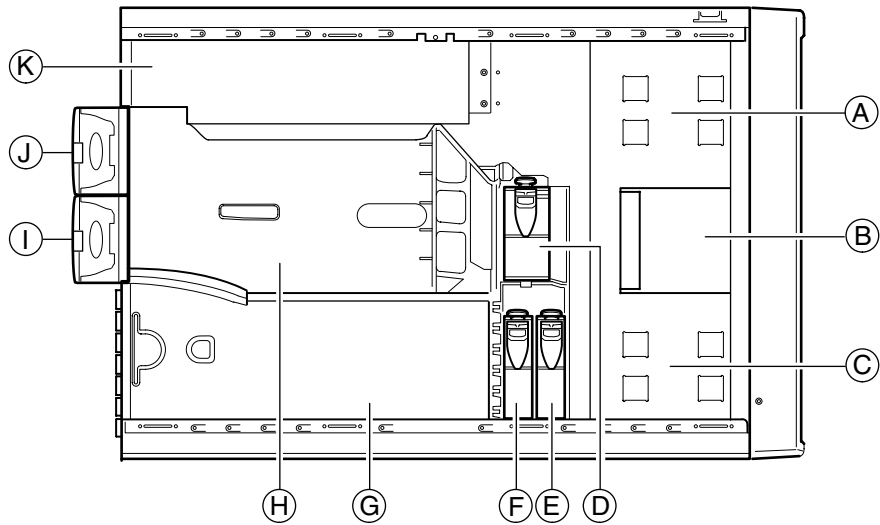

OM14012

- A. 5.25-inch removable media drive bays
- B. Diskette drive*
- C. 5.25-inch hard drive bays
- D. Hot-swap fan 5
- E. Hot-swap fan 4
- F. Hot-swap fan 3
- G. PCI Area Duct
- H. Processor Area Duct
- I. Hot-swap fan 2
- J. Hot-swap fan 1
- K. Power supply

* Items shown may differ in your chassis.

Figure 6. Chassis Side View

Peripherals

5.25-inch Removable Media Drive Bays

The upper bays are designed for removable media peripherals. You can install up to two half-height peripherals or one full height peripheral. For proper cooling, the lowest position must remain open.

5.25-inch Hard Drive Bays

The lower two drive bays are designed for hard drives.

3.5-inch Hot-Swap Drive Bay

The hot-swap drive bay supports up to five 3.5-inch SCA LVDS hard drives. Five carriers are included with the system. If no drive is installed in a carrier, a plastic air baffle must be installed to ensure proper hard drive cooling.

The hot-swap drive bay accepts 1-inch hard drives that consume up to 18 watts of power. Drives must be specified to operate at a maximum ambient temperature of 50 °C. An optional second Hot-Swap Drive Bay is available.

Optional DLT Bracket

An optional DLT bracket is available (such as a DLT Drive) and slim-line a CD-ROM drive or two half-height peripherals and a slim-line CD-ROM drive.

Accessories and Order Codes

For a complete list of spares and accessories, see:

<http://www.intel.com/go/serverbuilder>

Table 4. Accessories and Order Codes

Accessory	Order Code
HS Drive Bay Upgrade Kit	AXX2HSDRVUG
Y-Cable for SCSI Backplane (Permits cabling two backplanes to one SCSI/RAID channel)	AHD3HSBPYCBL
Hot-Swap Fan Spare Kit (Two 80 mm fans and one 92 mm fan with carriers and connectors)	FHD3HSFANS
DLT Tape Drive and Slim Line CD-ROM Mounting Brackets	FHD2DLTBRK
ICMB Board Kit	AXX2ICMBKIT
External SCSI Adapter Cable	AXXEXTSCSICBL
Rack Kit	AHD3RACK
350 W Power Module	AXX2PSMODL350

Power Supply

The 650 watt, dual-line cord, 2+1 redundant power supply is auto ranging for either 100-120 VAC or 200-240 VAC.

The Intel® SC5200 Server Chassis Hot-Swap, Redundant Power ships with two power modules and a blank filler installed. A third power module (includes a second power cable) can be ordered as an accessory (Order Code: AXX2PSMODL350).

 **NOTE**

A redundant power configuration requires installation of three power modules and two power cords.

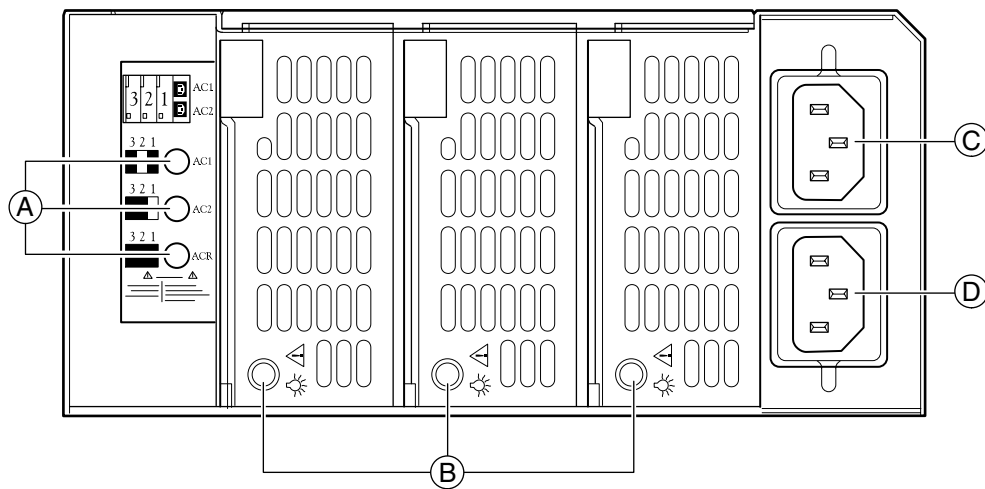

OM14031

- A. Redundancy LEDs
- B. Power Supply Module LEDs
- C. AC Power Cord 1
- D. AC Power Cord 2

Figure 7. Power Supply

Table 5. Redundancy LED Description

LED Name	Color	Condition	Description
AC1	Green	ON	AC Power Cord 1 (AC1) active and modules 1 & 3 active
		OFF	No AC power to AC Power Cord 1
AC2	Green	ON	AC Power Cord 2 (AC2) active and modules 2 & 3 active
		OFF	No AC power to AC Power Cord 2
ACR	Green	ON	Redundant Power active: all 3 modules active; both power cords active
		OFF	Redundant Power not active

Table 6. Power Module LED Description

LED Name	Color	Condition	Description
Power Module LED	Green	ON	Power supply DC outputs ON and OK
	Green	BLINK	AC power present/Only Standby outputs ON
	Amber	ON	Indicates one of these conditions: <ul style="list-style-type: none"> No AC power to this power supply module Power supply failure (includes over voltage, over temperature) Module current limit exceeded Check Server Management Software to diagnose problem
		OFF	No AC Power to System

Checking the Power Cords



WARNING

Do not attempt to modify or use the supplied AC power cords if they are not the exact type required.

The power supply cords are the main disconnect device to mains (AC power). The socket outlet shall be installed near the equipment and shall be readily accessible.

If a power cord supplied with the chassis is not compatible with the AC wall outlet in your region, get one that meets the following criteria:

- The cord must be rated for the available AC voltage and have a current rating that is at least 125% of the current rating of the server.
- The connector that plugs into the wall outlet must be a grounding-type male plug designed for use in your region. It must have certification marks showing certification by an agency acceptable in your region.
- The connector that plugs into the AC receptacle on the power supply must be an IEC 320, sheet C13, type female connector.
- In Europe, the cord must be less than 4.5 meters (14.76 feet) long, and it must be flexible <HAR> (harmonized) or VDE certified cordage to comply with the chassis' safety certifications.

Chassis Security

To help prevent unauthorized entry or use of the server, the chassis includes two chassis intrusion switches that can be monitored by Server Management software, a padlock loop at the rear of the chassis, and a front bezel door lock (pedestal only).

Monitoring

Two chassis intrusion switches are preinstalled. When the access cover is removed or the front bezel door is opened, the switch transmits a signal to the BMC on the server board. Server management software can be programmed to respond to an intrusion by powering down or by locking the keyboard, for example.

Mechanical Locks

A user-installed padlock loop (provided in the hardware kit) on the rear of the chassis access cover can be used to prevent access to the inside of the chassis. A variety of lock sizes can be accommodated by the .270 inch (7 mm) diameter loop. The front bezel has a two-position lock to prevent access to the hard drives and the interior of the chassis.

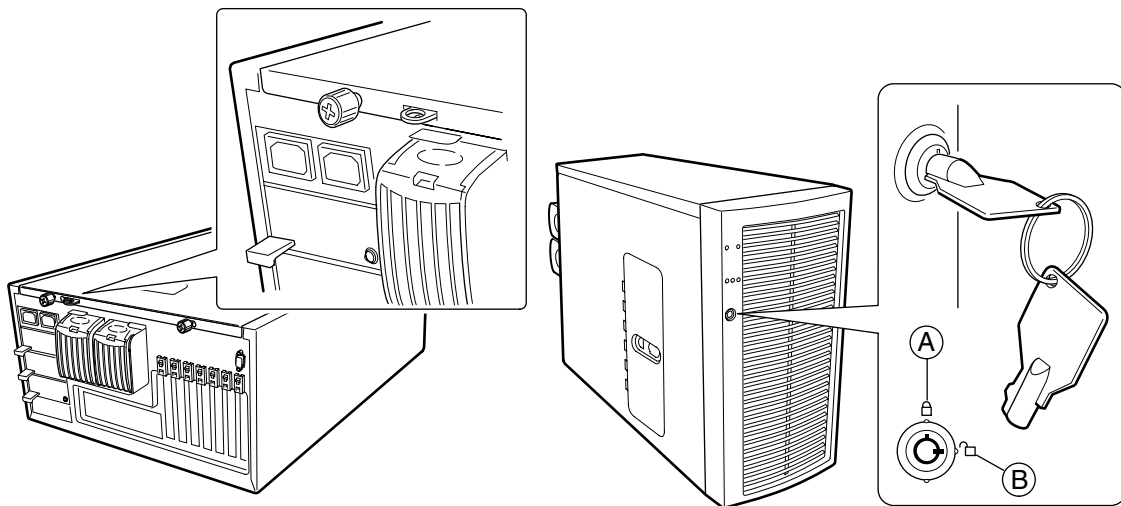

OM14013

- A. Front bezel locked
- B. Front bezel unlocked

Figure 8. Mechanical Locks

3 Setting Up the Chassis

This chapter describes how to set your server up for the first time.

Tools and Supplies Needed

- Phillips[†] (cross head) screwdriver (#2 bit)
- Antistatic wrist strap (recommended)

Installation Safety Instructions

Only technically qualified personnel should integrate this assembly.

Follow these guidelines to meet and maintain safety and product regulatory requirements when integrating this chassis subassembly.

Read and adhere to all of these instructions and the instructions supplied with this assembly. If you do not follow these instructions, the UL listing will be void, and the product will most likely be non-compliant with other regional product laws and regulations.

Safety: Before You Remove the Access Cover

Before removing the access cover for any reason, observe these safety guidelines:

1. Turn off all peripheral devices connected to the server.
2. Turn off the server by pressing the power button on the front of the chassis. Then unplug the AC power cords from the chassis or wall outlet.
3. Label and disconnect all peripheral cables and all telecommunication lines connected to I/O connectors or ports on the back of the chassis.
4. Provide some electrostatic discharge (ESD) protection by wearing an antistatic wrist strap attached to chassis ground—any unpainted metal surface—when handling components.

Warnings and Cautions

These warnings and cautions apply whenever you remove the access cover to access components inside the server. Only a technically qualified person should integrate and configure the server.



WARNINGS

The power button on the front panel DOES NOT turn off the AC power. To remove power from server, you must unplug the AC power cords from the wall outlet or the chassis.

Hazardous electrical conditions may be present on power, telephone, and communication cables. Turn off the server and disconnect the power cords, telecommunications systems, networks, and modems attached to the server before opening it. Otherwise, personal injury or equipment damage can result.

Hazardous voltage, current, and energy levels are present inside the power supply. There are no user-serviceable parts inside it; servicing should be done by technically qualified personnel.



CAUTIONS

ESD can damage disk drives, boards, and other parts. Perform all procedures in this chapter only at an ESD workstation. If one is not available, provide some ESD protection by wearing an antistatic wrist strap attached to chassis ground—any unpainted metal surface—on your server when handling parts.

Always handle boards carefully. They can be extremely sensitive to ESD. Hold boards only by their edges. Do not touch the connector contacts. After removing a board from its protective wrapper or from the server, place the board component side up on a grounded, static free surface. If you place the server board on a conductive surface, the battery leads may short out. If they do, this will result in a loss of CMOS data and will drain the battery. Use a conductive foam pad if available. Do not slide board over any surface.

For proper cooling and airflow, always install the access cover before turning on the server. Operating it without the cover in place can damage system parts.

Install the Front Door Grill – Pedestal-mounted (Tower) Server Only

1. Position the grill and the grill tab as shown.
2. Push the grill over the tabs on the door until the grill snaps in place.

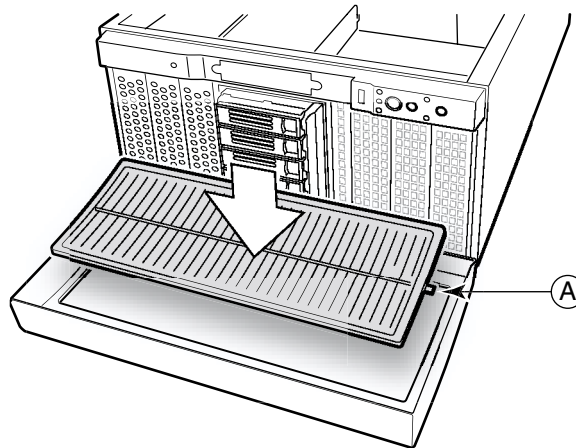

OM13917

A. Grill Tab

Figure 9. Installing the Grill

Remove the Access Cover

Facing the front of the chassis, the access cover is on the left side, for pedestal-mounted (tower) servers; or on the top, for rack-mounted servers.

1. Observe the safety and ESD precautions at the beginning of this chapter.
2. If the shipping screw is installed, remove it.
3. Loosen the captive thumbscrews that secure the access cover in place.
4. Slide the cover backward a short distance, until it stops.
5. Pull the entire cover outward, straight away from the chassis, to disengage the rows of tabs from the notches in the top and bottom edges of the chassis. Set the cover aside.

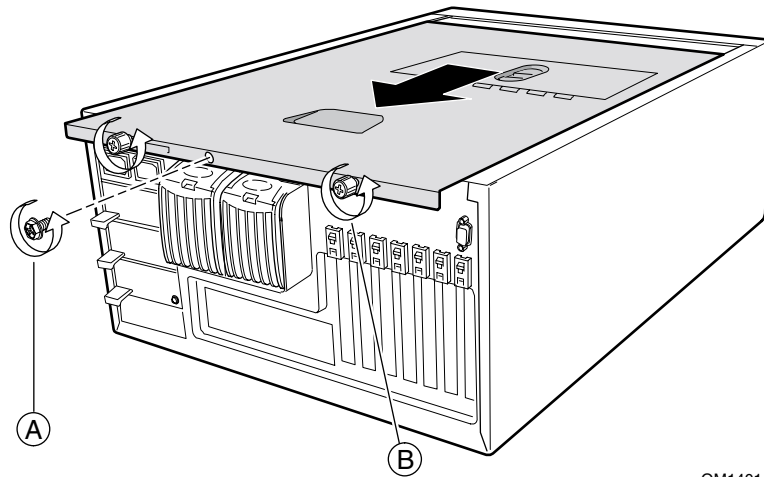

OM14014

- A. Shipping screw
- B. Thumbscrew

Figure 10. Removing the Access Cover

Remove the Plastic Air Ducts

1. Squeeze the Blue Latch on the duct covering the PCI expansion slots.
2. Lift the duct and pull it out of the hinge in the hot-swap fan holder.
3. Grip the Processor Area Duct Lift Tab on the duct covering the system processor(s) and lift the duct. Pull the duct toward the rear of the chassis to disengage it from the hinge in the hot-swap fan holder and remove it.

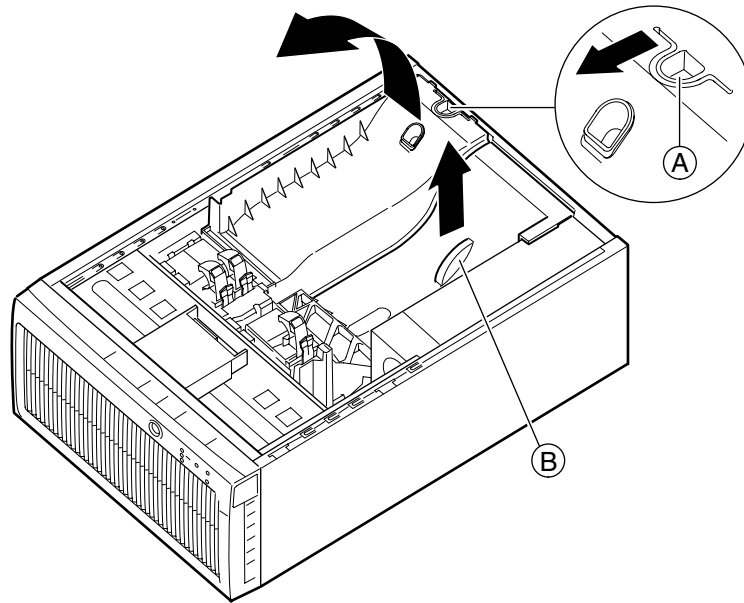

OM14015

- A. Blue Latch
- B. Processor Duct Lift Tab

Figure 11. Removing Air Ducts

Install the I/O Shield

NOTE

An ATX 2.03-compliant I/O shield should be provided with your server board. The shield is required by Electromagnetic Interference (EMI) regulations. It minimizes EMI and ensures proper cooling of the server.

The shield fits the rectangular opening near the power supply in the back of the chassis. The shield has cutouts that match the external I/O connectors (e.g., keyboard and mouse).

1. Install the EMI Gasket on the I/O Shield, if one was provided with your server board.
2. Install the shield from inside the chassis. Orient the shield so that the cutouts align with the corresponding I/O connectors on the server board.
3. Position one edge so that the dotted groove is outside the chassis wall and the lip of the shield rests on the inner chassis wall.
4. Hold the shield in place, and push it into the opening until it is seated. Make sure the I/O shield snaps into place all the way around.

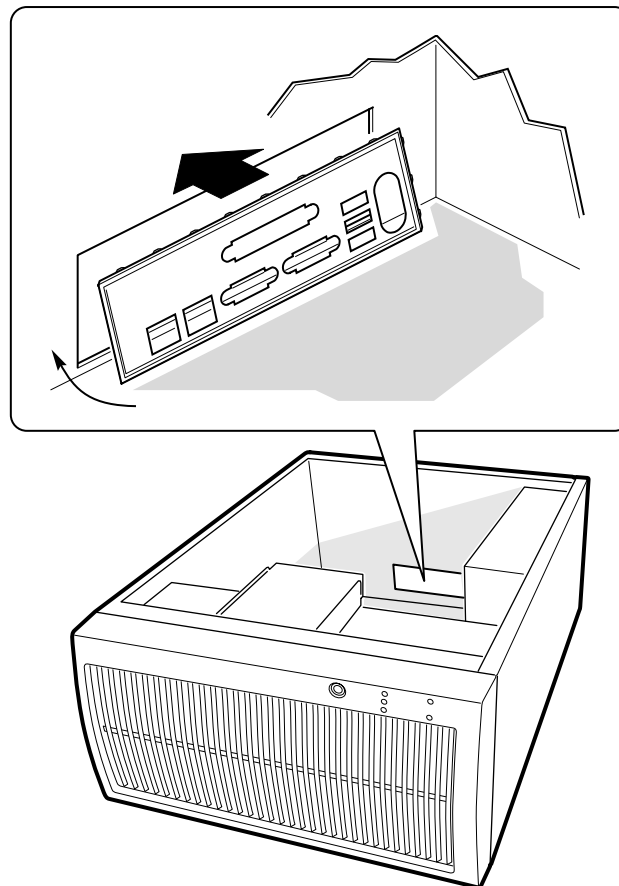

OM11956

Figure 12. Installing the I/O Shield

Install the Server Board Bumpers

Please see the quick start user guide that shipped with your server board for the information on server board bumpers.

Install the Server Board

NOTE

Processor(s) should be installed with a heat sink but without attached cooling fans. Attached cooling fans cannot be used in conjunction with this server chassis plastic ducting.

See your server board quick start user guide for more information on how to install your server board, processors, and memory.

1. See your server board documentation for instructions for installing chassis standoffs.
2. Tilt the board into the chassis I/O connector end first. Make sure the I/O connectors stick out through the I/O shield.
3. Insert one screw through one of the mounting holes of the board and into a threaded standoff. Do not tighten the screw until the next step.
4. Insert the remaining screws through the mounting holes and into the threaded standoffs. Make sure the board is properly seated, and then tighten all the screws firmly, starting with the screws in the center of the board.

Connect Cables to the Server Board

See your server board product guide or quick start guide for connector locations.

1. Connect the power cables to the server board.
 - The large plug labeled P1 plugs to the main power connector on the server board.
 - The plug labeled P2 plugs to the AUX power connector on the server board.
 - The plug labeled P3 plugs into the +12 V CPU power connector on the server board (if available).
2. Connect the front panel cable to the server board.
 - The front panel cable is already connected to the front panel and is routed correctly.
3. Connect each fan cable to the appropriately numbered fan connector on the server board. Hot-swap fan numbers are printed on the internal hot-swap fan carrier, on the external hot-swap fan case, and on the hot-swap fan cables.
4. If you plan to use an IDE removable media device in the upper drive bays, connect the IDE cable for the upper device bays to the server board.
 - The cable is already is routed correctly.
5. Connect the floppy cable to the server board. Route the floppy cable between the internal system fan holder and the chassis wall.
6. Connect the SCSI cable(s) to the server board.
 - The SCSI cable is already connected to the hot-swap bay and is routed correctly.
 - Connect the SCSI cable to a SCSI connector on your server board.
7. Connect the chassis intrusion cable to the server board.
8. Connect the I2C cable from the hot-swap bay to the HSBP-A connector on the server board.
9. If desired connect the serial port 2 cable to the server board and mount it on the rear (pedestal and rack) or front (pedestal only) of the chassis.
10. Connect the USB cable from the front panel to the server board. Route the USB cable between the internal system fan holder and the chassis wall.

NOTE

If you wish to customize the routing of pre-installed cables or dress the cables, you can remove the internal system fan holder by removing the three screws that secure it to the chassis baseplate.

Install the Diskette Drive

NOTE

We highly recommend you use a magnetic screwdriver for this step. A nonmagnetic screwdriver may lose the screws between the chassis and the plastic bezel.

1. Remove the EMI shield that is mounted in the carrier.
2. Remove the plastic filler panel.
3. Using a magnetic screwdriver, remove the two screws that hold the diskette drive carrier to the front of the chassis.
4. Slide the carrier towards the rear of the chassis, until it comes free.

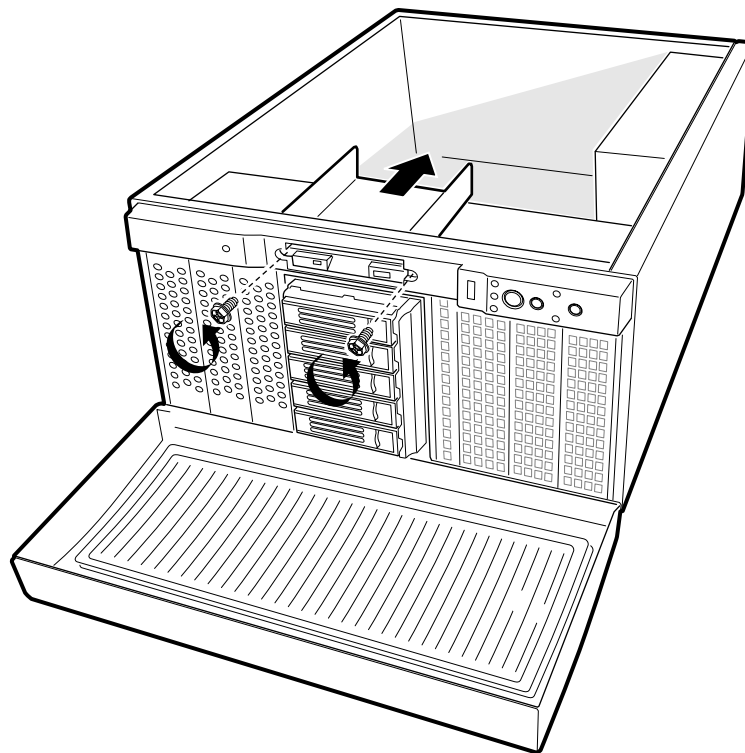

OM11960

Figure 13. Removing the Diskette Drive Carrier

5. Remove the 3.5-inch diskette drive from its protective wrapper. Record the drive model and serial numbers in your equipment log.
6. Set any jumpers or switches according to the drive manufacturer's instructions.
7. Slide the drive into the drive carrier component-side down.

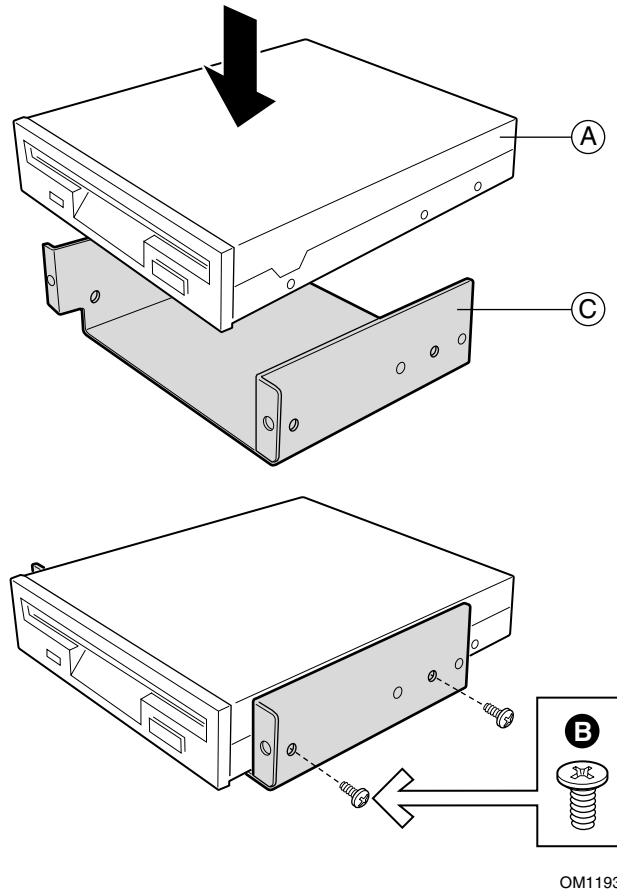

OM11934

- C. Diskette drive
- D. Screw (M3 flat head)
- E. Carrier

Figure 14. Installing the Diskette Drive into the Drive Carrier

8. Insert and tighten four screws (fine thread flat head) to attach the drive to the carrier.
9. Position the carrier so the front of the drive fits correctly in the front opening of the chassis. When properly positioned, the hole in the carrier aligns with the threaded hole in the frame.
10. Secure the assembly to the front of the chassis with the two screws removed in step 1; tighten the screws firmly.

11. Connect data and power cables to the drive.

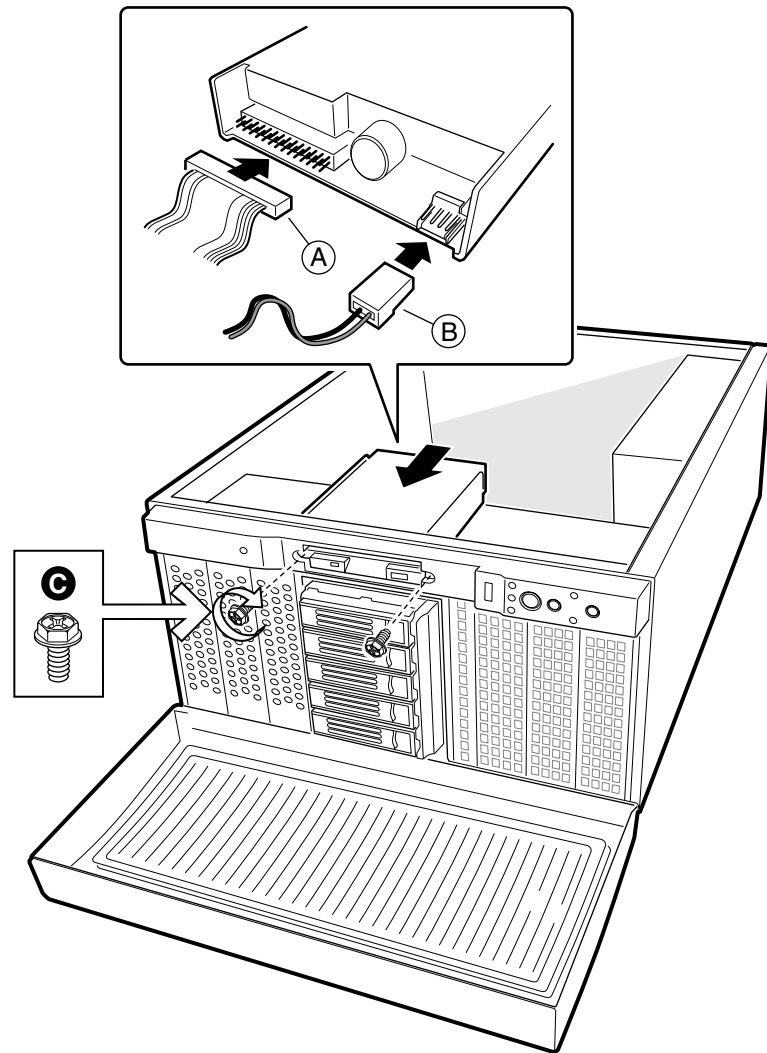

OM11933

- A. Data cable
- B. Power cable
- C. Screws

Figure 15. Installing the Diskette Drive/Carrier Assembly

12. Route the floppy drive cable between the plastic fan carrier and the side of the chassis as shown.

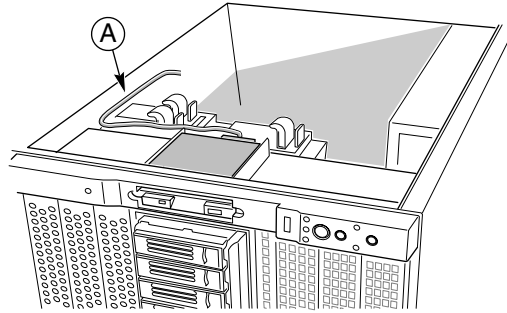

OM14205

A. Floppy Cable

Figure 16. Routing the Floppy Drive Cable

Hard Drives

Drive Cabling Considerations

The cable that ships with the chassis is pre-folded to fit the chassis. To minimize the chance of damaging a cable, you should keep the cables folded correctly. The number of devices you can install depends on:

- The number supported by the bus on your server board
- The number of physical drive bays available
- The combination of SCSI and IDE devices

IDE Requirements

If no drives are present on an IDE channel, do not connect the IDE cable to the server board.

NOTE

To disable the IDE controller: If you plan to disable the IDE controller to reuse the interrupt for that controller, you must physically unplug the IDE cable from the board connector if a cable is present. Simply disabling the drive by configuring the SSU option does not make the interrupt available.

SCSI Requirements

One SCSI cable is provided with the chassis to connect the hot-swap back plane with the server board. This cable should be connected to a LVD SCSI connector on the server board or add-in RAID card.

If a second Hot-Swap Drive Bay is installed, an optional Y-cable is available to attach both SCSI back planes to a single SCSI channel.

Installing a 5.25-inch Removable Media Device

Two 5.25-inch half-height bays provide space for tape backup, CD-ROM, or other removable media drives.

NOTE

Save the EMI shields: EMI integrity and cooling are both protected by having drives installed in the bays or EMI shields covering the bays. When you install a drive, save the shield to reinstall in case you should later remove the drive and not reinstall one in the same bay.

CAUTION

For proper cooling, you must leave the bottom bay empty.

1. Remove the two screws that hold the shield in place.
2. Pull the shield out of the chassis. Save the shield for use if you remove the peripheral.

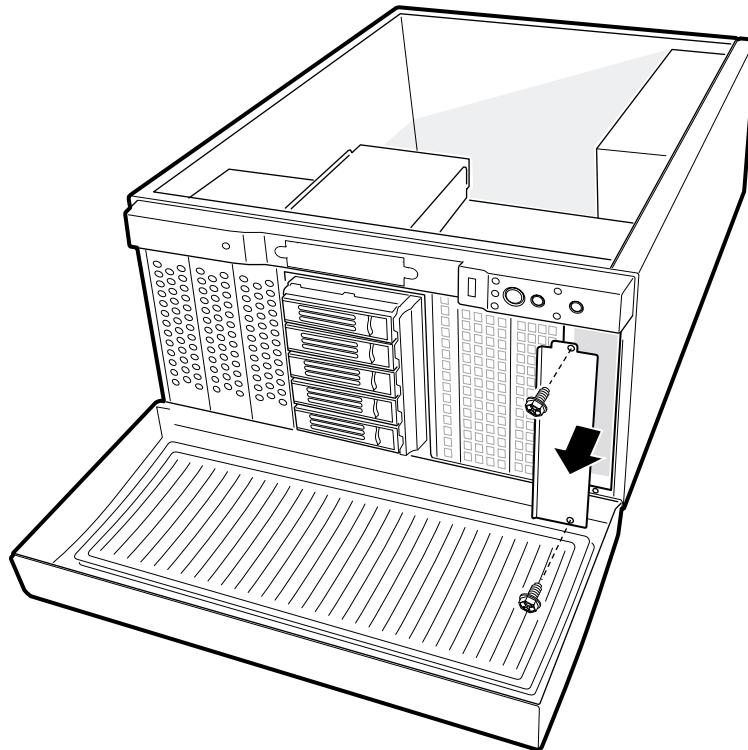

OM13715

Figure 17. Removing EMI Shields

3. Remove the drive from its protective wrapper and place it on an antistatic surface.
4. Record the drive model and serial numbers in your equipment log.
5. Set any jumpers or switches on the drive according to the drive manufacturer's instructions.
6. Using four screws of the appropriate size and length, attach two slide rails to the drive.

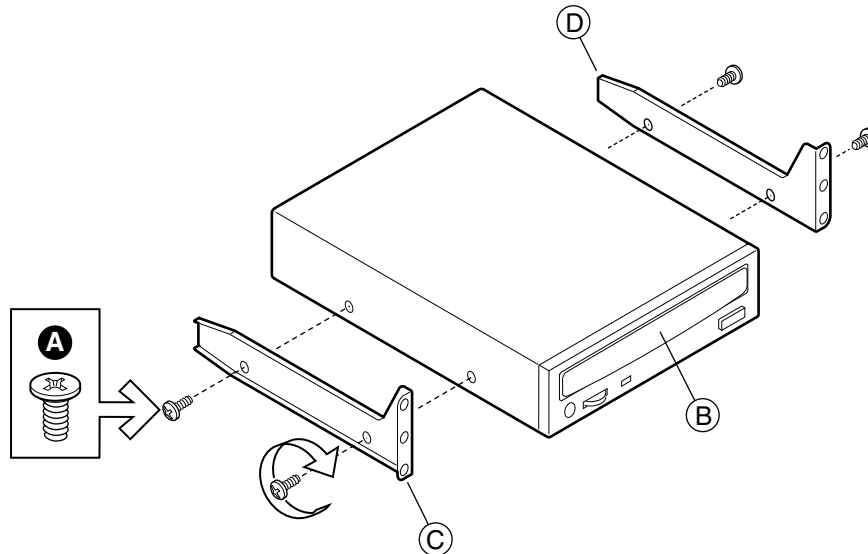

OM11941

- A. Screws (M3 flat head)
- B. CD-ROM drive or other removable media device
- C. Left rail
- D. Right rail

Figure 18. Slide Rails

7. Position the drive so the slide rails engage in the bay guide rails. Push the drive into the bay until the slide rails are flush with the chassis.

8. Remove the hot-swap fans from the plastic fan carrier.
9. Connect the data cable to the drive. The connectors are keyed and can be inserted in only one way. Connect a power cable to the drive.

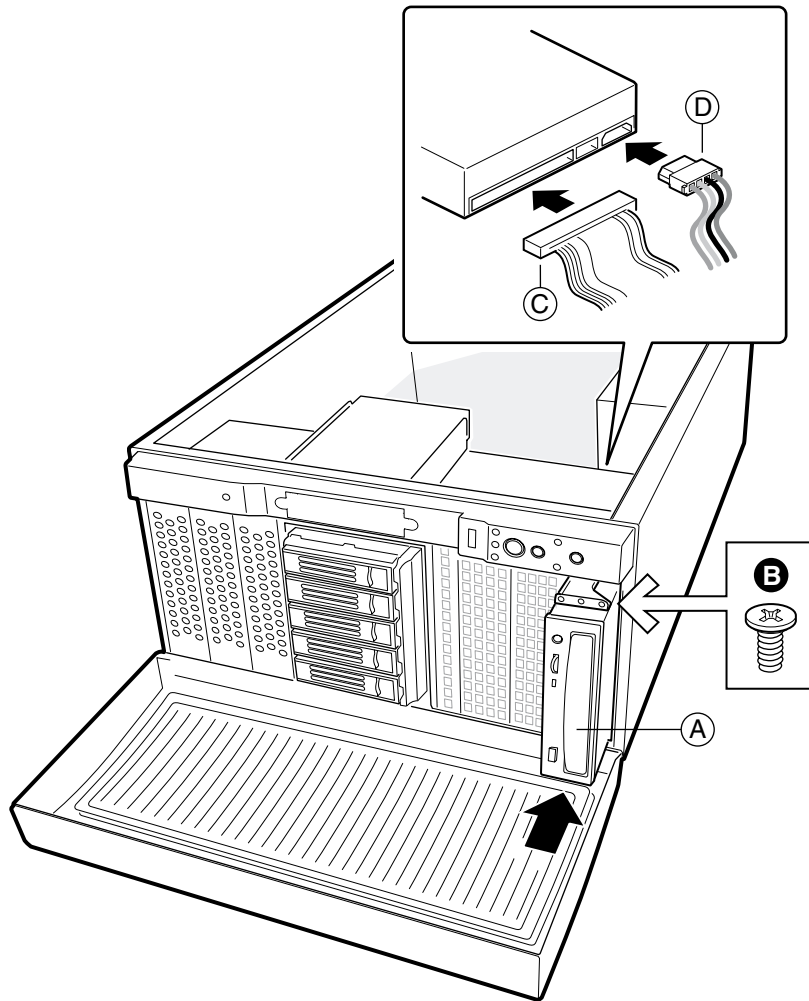

OM13717

- A. Removable media device
- B. Screw
- C. Data cable
- D. Power cable

Figure 19. Installing a Removable Media Device

Installing a 5.25-inch or 3.5-inch Hard Drive

CAUTION

For proper cooling, you must leave the bottom bay empty.

Two 5.25-inch half-height bays provide space for hard drives.

1. If you haven't already done so, remove hot-swap fan number 3 and hot-swap fan number 4 from the plastic fan carrier.
2. Remove and save the two screws that secure the drive carrier to the chassis.
3. Slide the drive carrier out of the chassis. You may need to push the carrier from the inside of the chassis.

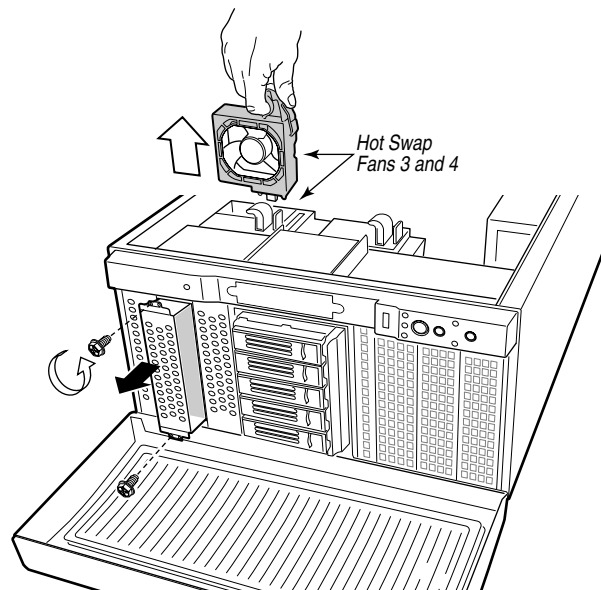

OM14207

Figure 20. Removing a Drive Carrier

4. Remove the drive from its protective wrapper and place it on an antistatic surface.
5. Record the drive model and serial numbers in your equipment log.
6. Set any jumpers or switches on the drive according to the drive manufacturer's instructions.

7. Place the drive into the carrier component-side down and with the power and data connectors facing the rear of the carrier. The connectors should be flush with the rear of the carrier.
8. Holding the drive in place, turn the carrier upside down.

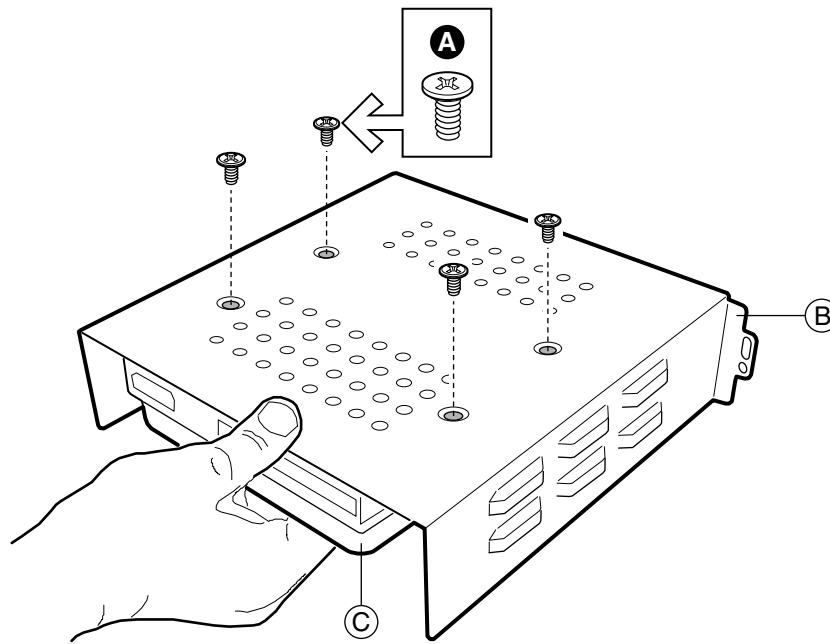

OM11943

- A. Screw (6-32 flat head)
- B. Drive carrier
- C. Hard drive

Figure 21. Attaching a Hard Drive to a Carrier

9. Line up the screws holes in the carrier with the screw holes in the drive.
10. Using four screws of the appropriate size and length, attach the drive to the carrier.

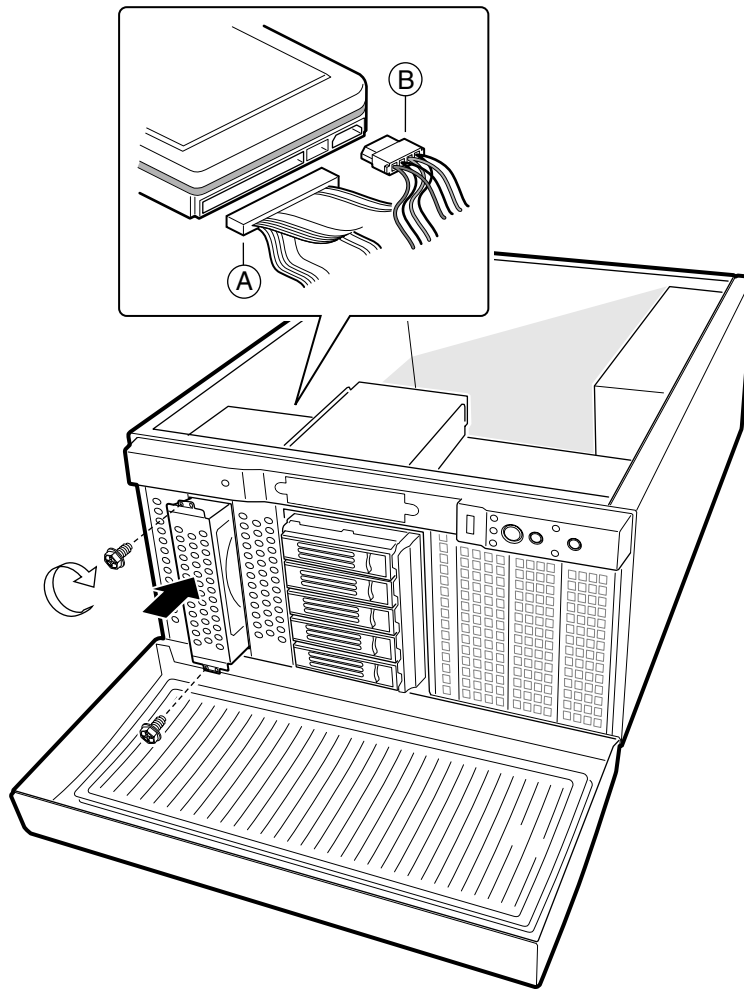

OM11948

- A. Data cable
- B. Power cable

Figure 22. Installing a Carrier

11. Slide the carrier into the chassis.
12. Insert and tighten the screws removed in Step 2.
13. Attach data and power cables to the drive.
14. Route the data cable between the plastic fan carrier and the chassis.
15. Insert hot-swap fan number 3 and hot-swap fan number 4 in the plastic fan carrier.

Hot-Swap SCSI Hard Disk Drives

The chassis contains a hot-swap drive bay and 5 drive carriers, but no hard disk drives. Refer to the Intel customer support website for a list of approved SCSI devices:

<http://support.intel.com/support/motherboards/server/chassis/sc5200>



CAUTION

Electrostatic discharge (ESD) and ESD protection: ESD can damage disk drives, add-in boards, and other components. This server can withstand normal levels of environmental ESD while you are hot-swapping SCSI hard disk drives. However, we recommend doing all procedures in this manual only at an ESD-protected workstation. If one is not available, you can provide some ESD protection by wearing an antistatic wrist strap attached to chassis ground of the server—any unpainted metal surface—when handling components.

Installing a Hot-Swap Hard Disk Drive

1. Press the green latch on the top of the carrier handle down, pull the carrier handle toward you, and pull the carrier from the chassis.
2. Remove the four screws that hold the air baffle to the carrier.

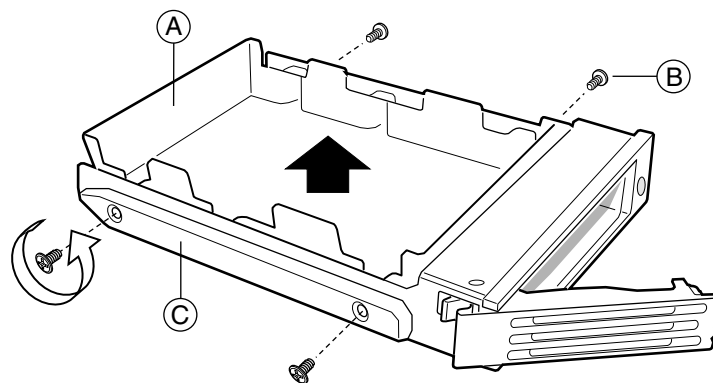

OM11940

- A. Air baffle
- B. Screw (save for reuse (6-32 flat head))
- C. Drive carrier

Figure 23. Removing the Air Baffle from the Drive Carrier

3. Remove the 3.5-inch hard drive from its wrapper and place it on an antistatic surface.
4. Record the drive model and serial number in your equipment log.
5. Orient the drive as shown in Figure 24.
6. Using the four screws removed earlier, attach the carrier to the drive.

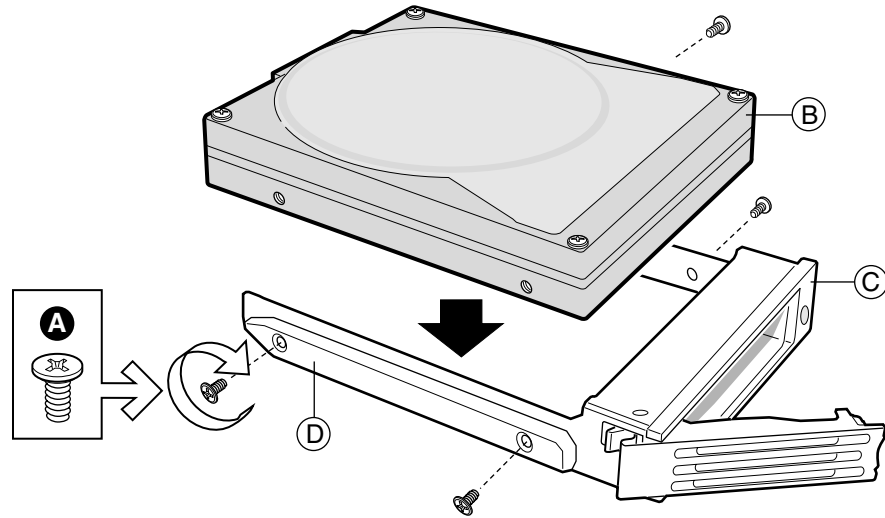

OM11935

- A. Screw (6-32 flat head)
- B. Hard drive
- C. Drive carrier
- D. Positioning rail

Figure 24. SCA Hard Disk Drive and Hot-Swap Drive Carrier

7. Position the drive carrier so it engages the guide rails.
8. Push the drive into the chassis until the tab engages the hole in the drive bay.
9. Push the carrier handle up until the latch clicks.

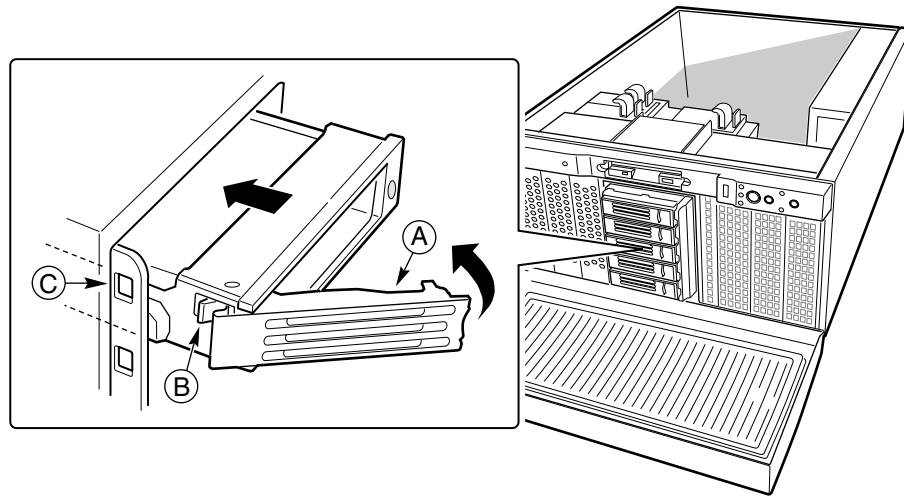

OM14206

- A. Latch
- B. Tab
- C. Hole

Figure 25. Inserting a Hot-Swap Drive

Installing an Add-in Board

You may want to install an operating system before installing any add-in boards. If so, skip this step and return to it when you are ready.



CAUTIONS

Do not overload the server board by installing add-in boards that draw excessive current.

Add-in boards can be extremely sensitive to ESD and always require careful handling. After removing the board from its protective wrapper or from the server board, place it component side up on a grounded, static free surface or conductive foam pad—if available. Do not slide the board over any surface.



NOTES

You may have to remove the serial port cable to install a board in slot 6.

If you plan to transport the system before use, you may wish to use the Hex head 6-32 x 6 mm screws included with your chassis to secure an add-in board.

1. Release the PCI retention mechanism by pressing it down and outward from the inside of the chassis.

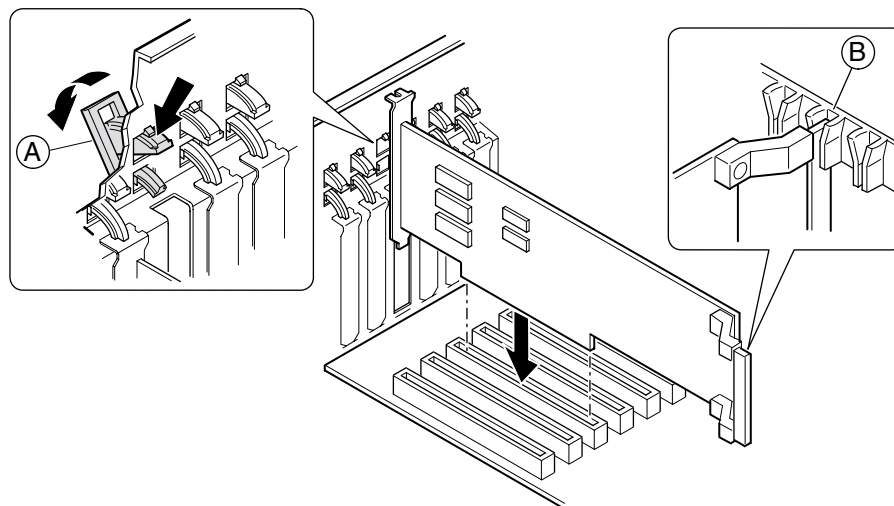

OM14018

- A. PCI Retention Mechanism
- B. Full-length Add-In Board Retention Groove

Figure 26. Installing an Add-in Board

2. Remove and save the snap-in expansion slot cover.
3. Remove the add-in board from its protective wrapper. Be careful not to touch the components or gold edge connectors. Place board on an antistatic surface.
4. Record the type and serial number of the add-in board in your equipment log.
5. Set jumpers or switches according to the manufacturer's instructions.

6. Hold board by its top edge or upper corners. Align full-length PCI add-in boards in the retention grooves in the plastic fan carrier. Firmly press it into an expansion slot on the server board. The tapered foot of the board retaining bracket must fit into the slot in the expansion slot frame.
7. Align the rounded notch in the retaining bracket with the threaded hole in the frame. The bracket fits the space that was occupied by the slot cover.
8. Close the PCI retention mechanism by pushing it into place from outside the chassis. Attach cables if necessary.

Install the Plastic Air Ducting

1. Place the tabs on the air duct that covers the processor(s) into the hinge slots on the plastic fan carrier and lower the duct into the chassis.

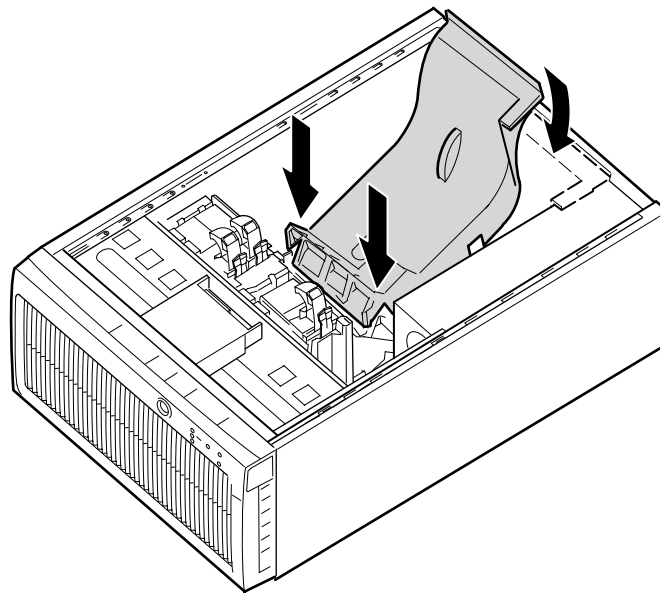

OM14019

Figure 27. Installing Processor Area Air Duct

2. Place the tabs on the air duct that covers the PCI slot area of the server board into the hinge slots on the plastic fan carrier and lower the duct into the chassis.

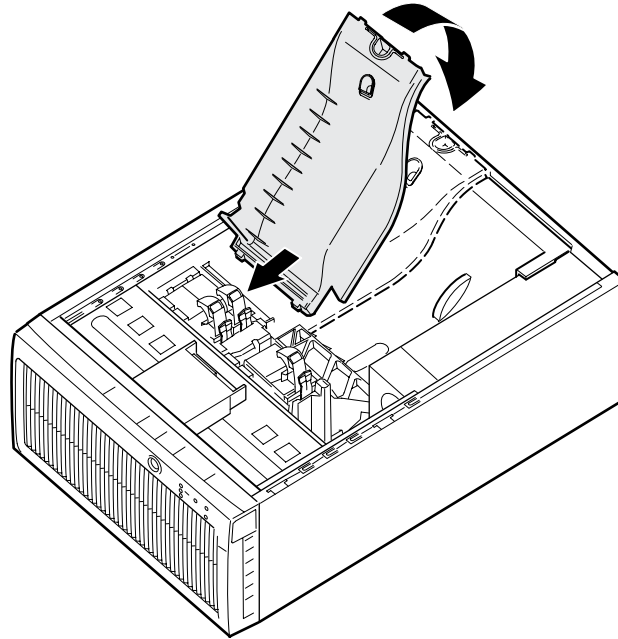

OM14020

Figure 28. Installing PCI Slot Area Air Duct

Install the Access Cover

1. Place the cover so the tabs go into the slots on the server. The cover should be flush against the chassis.
2. Slid the cover forward until it stops.
3. Tighten the two captive screws into the rear of the chassis.

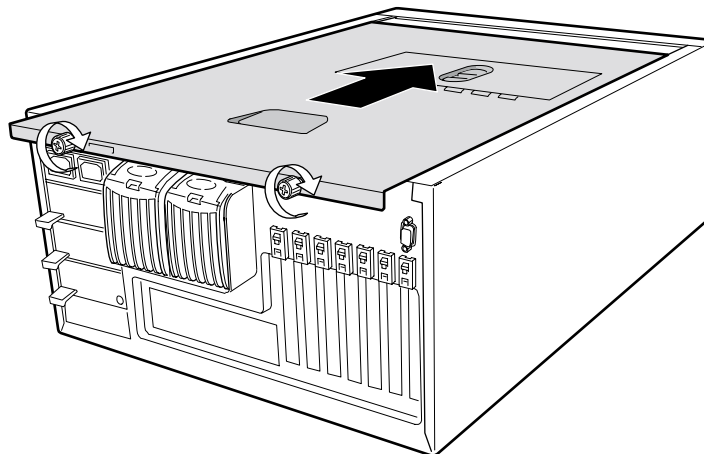

OM14021

Figure 29. Installing the Access Cover

Install the Chassis Feet (Pedestal Mode)

If you are installing this server into a rack system, skip these steps and read the instructions that came with your rack kit.

1. Move the chassis to the edge of your workbench.
2. Use four screws to attach each foot to the chassis. The holes in the feet will line up with only one set of holes in the chassis. On the front foot, the middle hole should be towards the front of the chassis. Hole locations for the front foot are marked “F” and “1,2”. On the back foot, the middle hole should be towards the back of the chassis. Hole locations for the rear foot are marked “F”.
3. You are now ready to attach a monitor, keyboard, and mouse to your server, and turn it on.

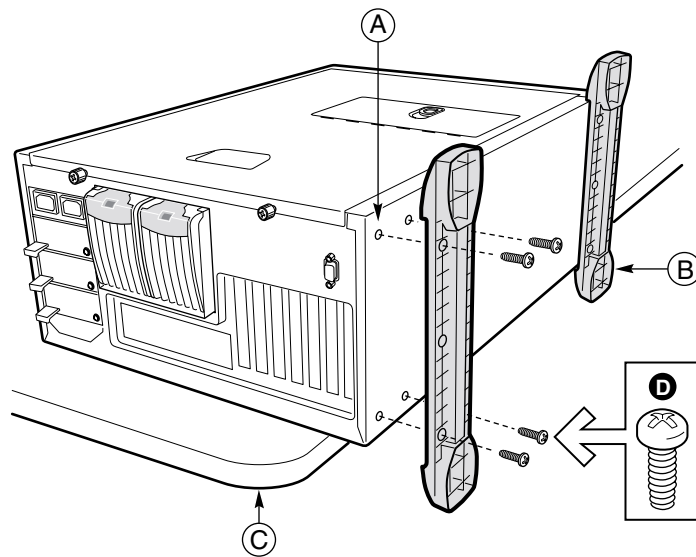

OM14209

- A. Screw hole
- B. Chassis foot
- C. Workbench
- D. Screw (M4 round head)

Figure 30. Installing the Chassis Feet

Install into a Rack (Rack Mode)

NOTE

Your chassis is designed to be compatible with the EIA-310-d rack standard. Be sure to select a rack cabinet enclosure that is EIA-310-d compliant. For additional compatibility and rack cabinet selection information, see:

<http://support.intel.com/support/motherboards/server/chassis/sc5200>

1. Fully extend the rails.
2. Remove the smallest and inner-most rail.
3. Position the rail.
4. Insert and tighten four screws.

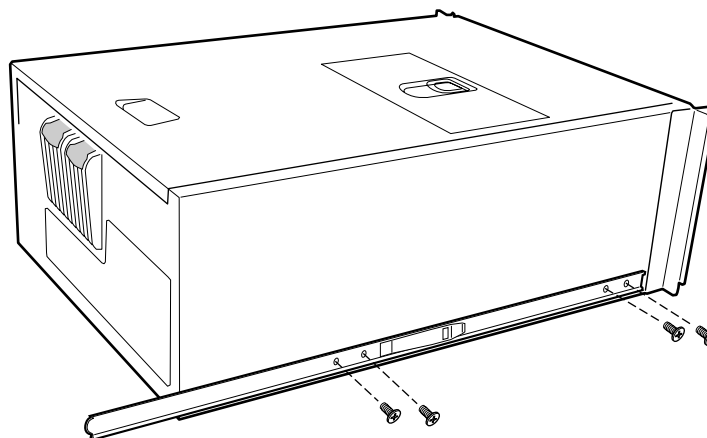

OM14210

Figure 31. Attaching the Rail to the Chassis

5. Install the rest of the rail in your rack.

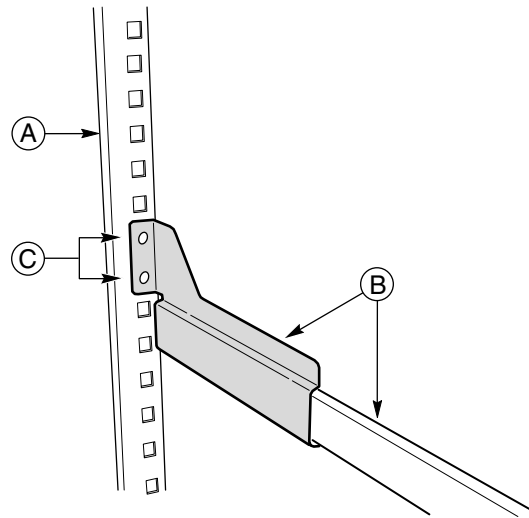

OM11973

- A. Rack
- B. Rail Assembly
- C. Mounting Holes

Figure 32. Rails Installed in a Rack

 **NOTE**

Your rack may vary from the illustration. Refer to your rack documentation for information specific to your rack.

6. Hold the chassis so the rails on the chassis engage the rails in your rack. You will need someone to help you at this point.

7. Disengage the locking tab on each rail and slide the server into the rack.

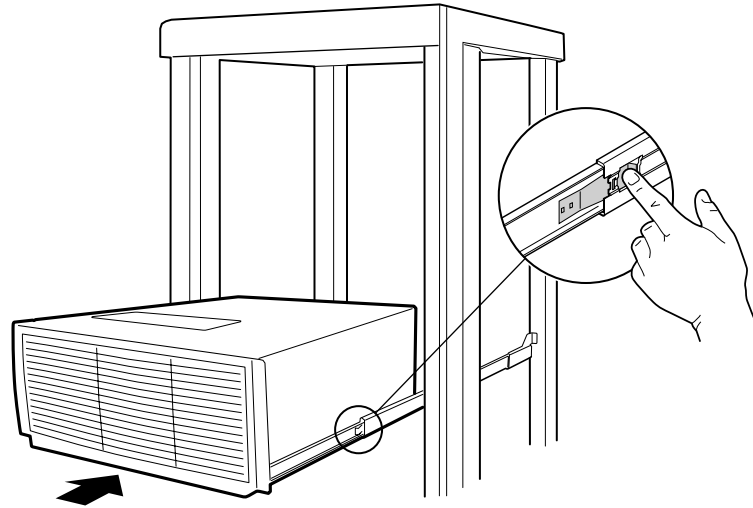

OM14211

Figure 33. Installing the Server into a Rack

4 Maintaining Your Server

This chapter describes how to replace components in your server after it has been set up. All references to top, sides, and directions in this chapter refer to a chassis in a pedestal mount.

Tools and Supplies Needed

- Phillips (cross head) screwdriver (#2 bit)
- Antistatic wrist strap (recommended)

Safety: Before You Remove the Access Cover

Before removing the access cover for any reason, observe these safety guidelines:

1. Turn off all peripheral devices connected to the server.
2. Turn off the server by pressing the power button on the front of the chassis. Then unplug the AC power cord from the chassis or wall outlet.
3. Label and disconnect all peripheral cables and all telecommunication lines connected to I/O connectors or ports on the back of the chassis.
4. Provide some electrostatic discharge (ESD) protection by wearing an antistatic wrist strap attached to chassis ground—any unpainted metal surface—when handling components.

Warnings and Cautions

These warnings and cautions apply whenever you remove the access cover to access components inside the server. Only a technically qualified person should integrate and configure the server.



WARNINGS

The power button on the front panel DOES NOT turn off the AC power. To remove power from server, you must unplug the AC power cord from the wall outlet or the chassis.

Hazardous electrical conditions may be present on power, telephone, and communication cables. Turn off the server and disconnect the power cords, telecommunications systems, networks, and modems attached to the server before opening it. Otherwise, personal injury or equipment damage can result.

Hazardous voltage, current, and energy levels are present inside the power supply. There are no user-serviceable parts inside it; servicing should be done by technically qualified personnel.



CAUTIONS

ESD can damage disk drives, boards, and other parts. Perform all procedures in this chapter only at an ESD workstation. If one is not available, provide some ESD protection by wearing an antistatic wrist strap attached to chassis ground—any unpainted metal surface—on your server when handling parts.

Always handle boards carefully. They can be extremely sensitive to ESD. Hold boards only by their edges. Do not touch the connector contacts. After removing a board from its protective wrapper or from the server, place the board component side up on a grounded, static free surface. If you place the server board on a conductive surface, the battery leads may short out. If they do, this will result in a loss of CMOS data and will drain the battery. Use a conductive foam pad if available but not the board wrapper. Do not slide board over any surface.

For proper cooling and airflow, always install the access cover before turning on the server. Operating it without the cover in place can damage system parts.

Replacing Fans

The chassis contains five replaceable hot-swap system fans. Your replacement fan should be the same size and type as the fan you are removing.

The redundant fans used by the power supply are not replaceable. In the event of a power supply fan failure, you must replace the power supply housing. To replace the power supply, see page 69.

Replacing a Front System Fan

1. Open the hot-swap fan access door.
2. Squeeze the latch to release the fan.
3. Remove the fan.
4. Wait 60 seconds for the System Software to update fan settings before installing the new fan.
5. Place the new fan into the plastic fan carrier until the latch clicks.
6. Close the hot-swap fan access door.

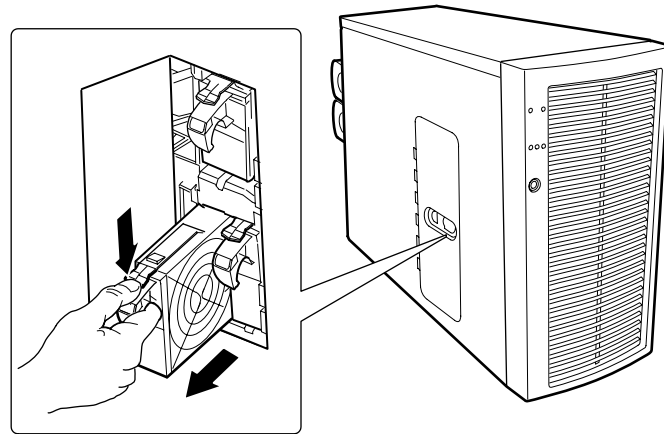

OM14024

Figure 34. Replacing a Front System Fan

Replacing a Rear System Fan

1. Press down on the fan latch.
2. Swing top of fan assembly away from the chassis to remove it.
3. Wait 60 seconds for the System Software to update fan settings before installing the new fan.
4. Position the bottom of the new fan on the metal fan holder.
5. Align the tabs on the bottom of fan assembly with the holes in the metal fan holder.
6. Swing top of fan assembly toward the chassis until latch clicks closed.

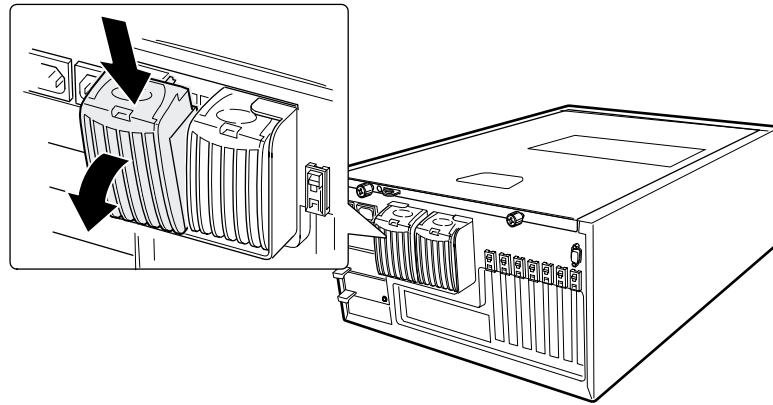

OM14025

Figure 35. Replacing a Rear System Fan

Replacing the Power Supply

WARNINGS

Hazardous conditions, power supply: Hazardous voltage, current, and energy levels are present inside the power supply. There are no user-serviceable parts inside it; servicing should be done by technically qualified personnel.

Hot-Swapping a Power Supply

CAUTION

Two hot-swap power modules must be installed and working when a module is removed. A single working module may not provide enough power for the system, leading to an immediate shutdown of the system.

1. Grasp the handle with your right hand, press the latch with your thumb.
2. Pull the handle down.
3. Slide the module out of the chassis.
4. Push the new power supply into the chassis until the latch clicks into place.

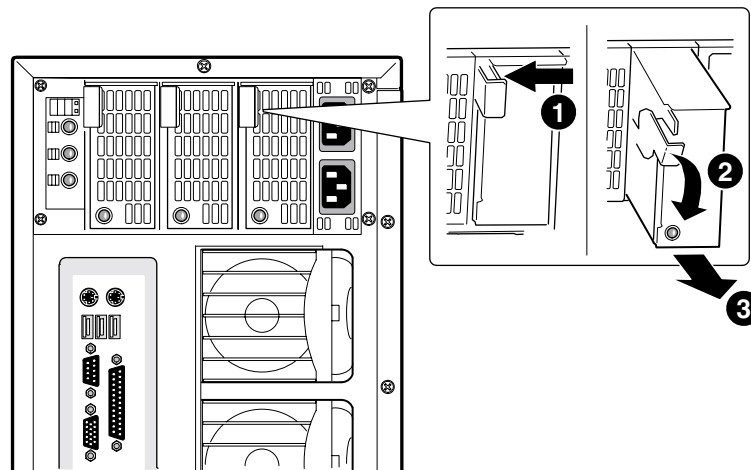

OM14026

Figure 36. Hot-Swapping a Power Supply

Replacing the Power Supply Housing

1. Disconnect the A/C power to the power supply.
2. Remove the hot-swap modules.
3. Remove the access cover.
4. Disconnect all the server board and peripheral power cables.
5. Remove and save the four screws at the rear of the chassis (Figure 37, B).
6. Remove and save the two screws from inside the chassis at the fan end of the power supply housing (Figure 37, A).

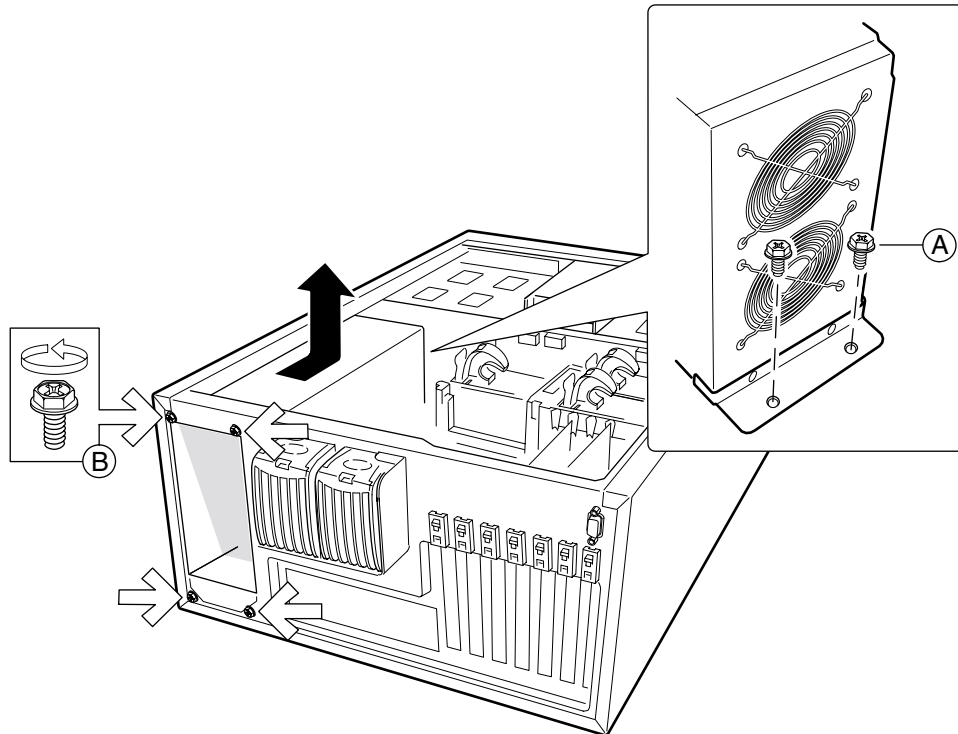

OM14027

- A. Screw locations
- B. Screw locations

Figure 37. Replacing the Power Supply Module

7. Remove the power supply from the chassis.
8. Install the new power supply into the chassis.
9. Insert and tighten the six screws (four at the rear, two at the fan end) that hold the power supply to the chassis.
10. Connect the power cables to the server board and peripherals.
11. Replace the access cover.
12. Reinstall the hot-swap modules.
13. Connect the A/C power to the power supply.

Replacing the Front Panel Board

1. Open the access cover.
2. Disconnect the front panel cable from the server board.
3. Disconnect the USB cable from the connector on the front panel.
4. Remove and save the three screws holding the front panel board to the chassis.
5. Remove the front panel board from the chassis.
6. Place the new front panel board in the chassis.
7. Insert and tighten the three screws removed earlier.
8. Re-connect the front panel board cables.
9. Replace the access cover.

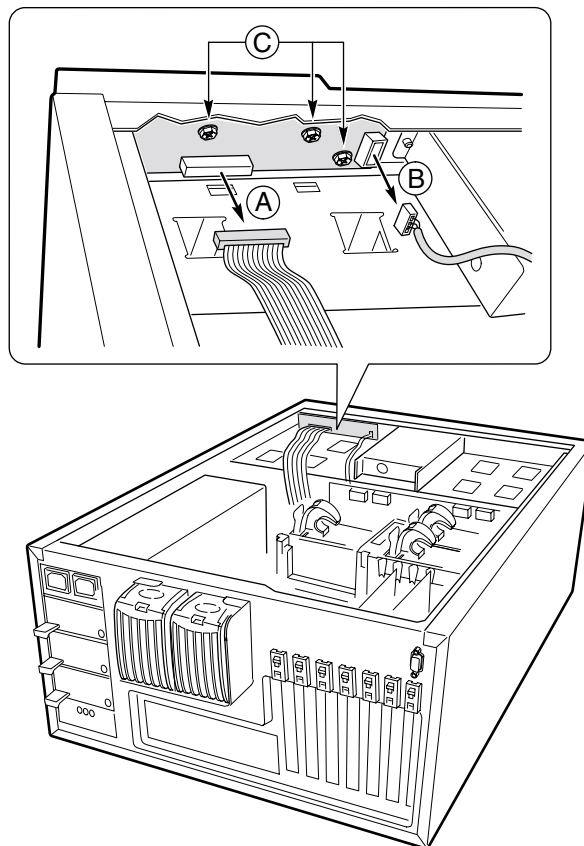

OM14028

- A. Front panel connector
- B. USB connector
- C. Screws

Figure 38. Replacing the Front Panel Board

Replacing the SCSI Backplane and SAF-TE Card

1. Remove all of the drive carriers from the hot-swap bay.
2. Open the access cover.
3. Remove plastic air ducting.
4. Remove the plastic fan carrier.

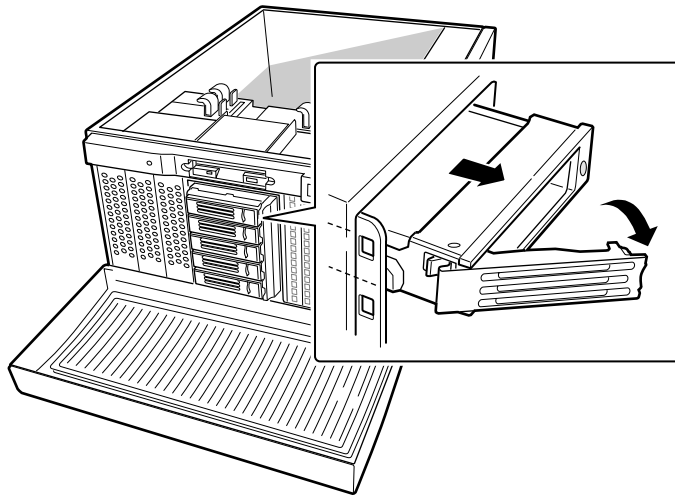

OM14214

Figure 39. Removing the Hot-Swap Drive Carriers

5. Disconnect the power cables and I2C cable from the hot-swap bay.
6. Remove and save the five screws holding the hot-swap bay to the chassis.

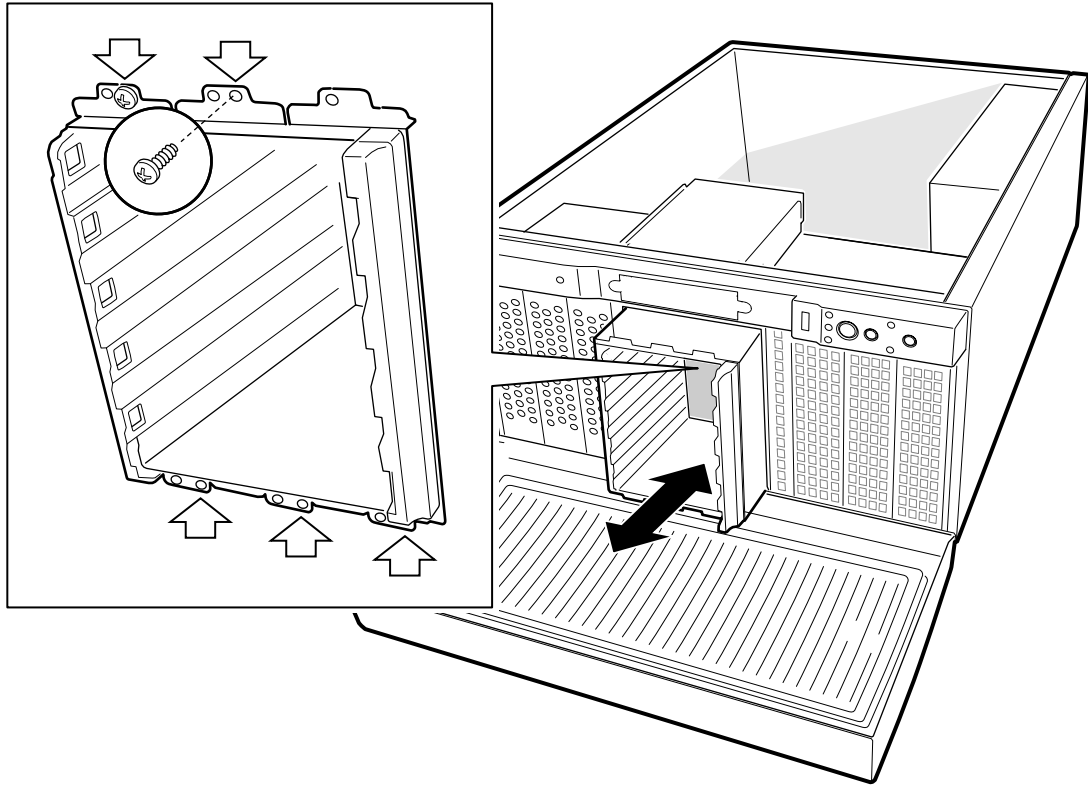

OM11944

Figure 40. Removing the Hot-Swap Drive Bay

7. Pull the hot-swap bay half way out of the chassis.
8. Disconnect the SCSI cable from the bay.
9. Remove the hot-swap bay from the chassis.

10. Remove and save the four screws that hold the backplane to the bay.

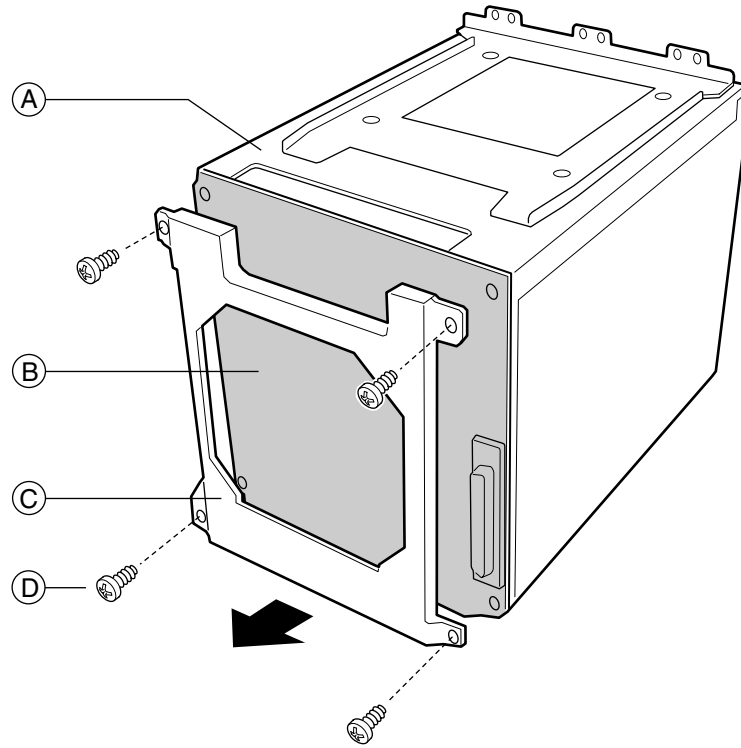

OM11945

- A. Hot-swap bay
- B. Hot-swap backplane
- C. Bracket
- D. Screw

Figure 41. Removing the Hot-Swap Backplane

11. Carefully pull the backplane straight out from the bay. The SAF-TE card is connected to the backplane and may be damaged if you don't pull it straight out.

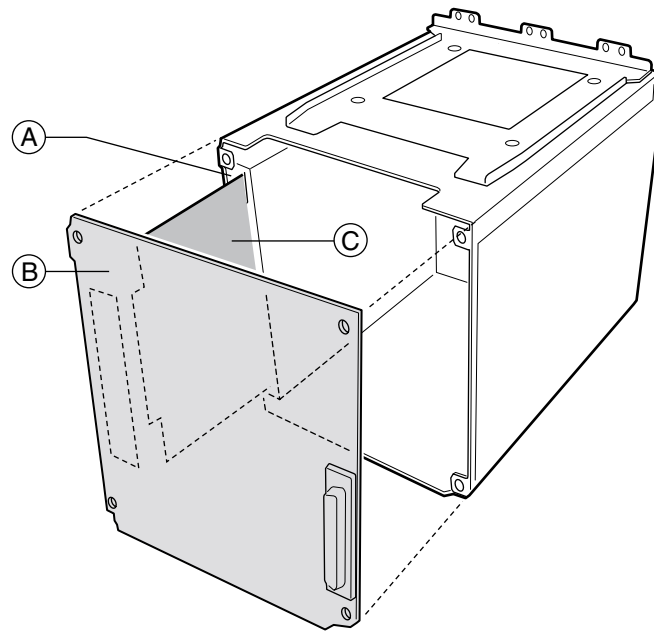

OM11958

- A. Notch for SAF-TE card
- B. Hot-swap backplane
- C. SAF-TE card

Figure 42. Replacing the Hot-Swap Backplane

12. If you are replacing the hot-swap backplane, do the following:
 - a. Remove the SAF-TE card from the old hot-swap backplane.
 - b. Plug the SAF-TE card into the new hot-swap backplane.
13. If you are replacing the SAFE-TE card, do the following:
 - a. Remove the old SAF-TE card from the hot-swap backplane.
 - b. Plug the new SAF-TE card into the hot-swap backplane.

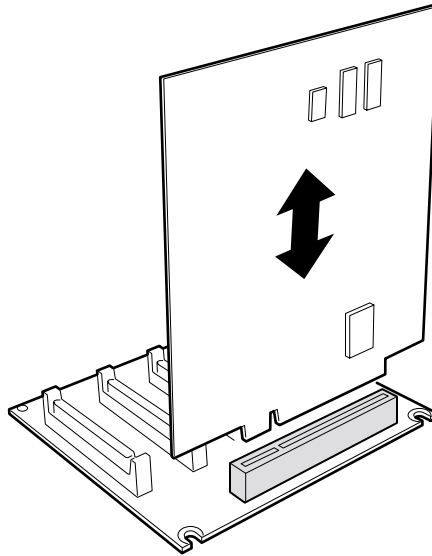

OM11959

Figure 43. SAF-TE Card and Hot-Swap Backplane

14. Carefully slide the SAF-TE card/hot-swap backplane assembly into place on the hot-swap bay.
The SAF-TE card slides through two notches on the bay.
15. Place the bracket on the backplane.
16. Insert and tighten the four screws that hold the backplane in place.
17. Slide bay half way into the chassis.
18. Connect the SCSI cable to the backplane.
19. Slide the bay the rest of the way into the chassis.
20. Insert and tighten the five screws that hold the bay in the chassis.
21. Connect the power cables and I2C cable to the backplane.
22. Install the plastic fan carrier and the plastic air ducting.
23. Replace the access cover.
24. Replace the hot-swap drives and carriers.

5 Technical Reference

Power Supply Specifications

Input Voltages

650 watt 2+1 power supply

- 100-120 V~ at 50/60 Hz; 13.4 A max.
- 200-240 V~ at 50/60 Hz; 16.7 A max.

Output Voltages

The table below lists the total wattage available from the power subsystem for each voltage. If you configure your system heavily, ensure that your loads do not exceed the combined total wattage of 650 watts. For information about calculating the power usage for your configuration, see page 87.

Table 7. Power Supply System Output Capability

Voltage	Maximum Current
+3.3 V	38 A
+5.0 V	38 A
+5 V Standby	2 A
+12.0 V	47.5 A
-12.0 V	0.5 A



CAUTION

Do not exceed a combined power output of 285 watts for the +5 V and +3.3 V outputs. Exceeding a combined 285 watts will overload the power subsystem and may cause the power supplies to overheat and malfunction.

The expansion slots on the server board are rated for no more than 25 watts for any one slot. The average current usage per slot should not exceed 13 watts.

System Environmental Specifications

Table 8. Environmental Specifications

Temperature	
Non-operating	–40° to 70 °C.
Operating	5° to 35 °C; derated 0.5 °C for every 1000 ft (305 m) to a maximum of 10,000 ft.
Humidity	
Non-operating	95% relative humidity (non-condensing) at 30 °C.
Shock	
Operating	2.0 g, 11 msec, 1/2 sine
Packaged	Operational after a 18" free fall, although cosmetic damage may be present.
Acoustic noise	55 dBA in a typical office ambient temperature (65-75 °F). Your selection of peripherals may change the noise level.
Electrostatic discharge (ESD)	Tested to 15 kilovolts (kV); no component damage.

6 Product Regulatory Compliance Information

This product has been verified to comply with the following safety standards / requirements:

Product Safety

Argentina	Resolution S.I.C.M No. 92/98
Australia / New Zealand	AS/NZS 3562
Canada / USA	UL60 950 – CSA60 950
European Union	EN60 950 & 73/23/EEC
Germany	EN60 950
International	IEC 60 950, 3 rd Edition
Nordics	EMKO-TSE (74-SEC) 207/94

Electromagnetic Compatibility (EMC) - Emissions

Australia / New Zealand	AS/NZS 3548 (Class A)
Canada	ICES-003 (Class A)
European Union	EN55022: 1994 (Class A) & 89/336/EEC
International	CISPR 22, 3 rd Edition (Class A)
Japan	VCCI (Class A)
Korea	MIC Notice 1997-42 (Class A)
Russia	GOST-R 29216-91 (Class A)
Taiwan	BSMI CNS13438
USA	Title 47 CFR, Part 15 (Class A)

Electromagnetic Compatibility - Immunity

European Union	EN55024: 1998
International	CISPR 24: 1st Edition
Korea	MIC Notice 1997-41
Russia	GOST-R 50628-95

Power Line Harmonics / Voltage Flicker

European Union	EN61000-3-2 / EN61000-3-3
International	IEC61000-3-2
Japan	JEIDA

Table 9. Product Regulatory Compliance Markings

Country	Markings on Product or Packaging	Marking Description
Argentina		IRAM Safety Compliance Mark
Australia / New Zealand		EMC Compliance Mark. Note : As shown indicates that the compliance folder is held in Australia
Canada		System Compliance Safety Mark (same for USA)
	CANADA ICES-003 CLASS A	EMC Compliance Mark
European Union / Nordics		Declaration of Conformity Mark
Germany		System Safety Compliance Mark
Japan	この装置は、クラス A 情報技術装置です。この装置を家庭環境で使用すると電波妨害を引き起こすことがあります。この場合には使用者が適切な対策を講ずるよう要求されることがあります。VCCI-A	EMC Compliance Mark – Class A
Korea		EMC Compliance Mark
Russia		Safety & EMC Compliance Mark
Taiwan		BSMI Certification Number
	警告使用者： 這是甲類的資訊產品，在居住的環境中使用時，可能會造成射頻干擾，在這種情況下，使用者會被要求採取某些適當的對策	BSMI EMC Warning for Class A Devices
USA		System Compliance Safety Mark (same for Canada)
	This device complies with Part 15 of the FCC Rules. Operation of this device is subject to the following two conditions: (1) This device may not cause harmful interference, and (2) This device must accept any interference received, including interference that may cause undesired operation. Manufactured by Intel Corporation	EMC Compliance Marking Statement – Class A Products

Regional EMC Compliance Information

Table 10. Regional EMC Compliance Information

Country	Compliance Information
<p>USA</p>	<p>FCC Verification Notice (Class A)</p> <p>This device complies with Part 15 of the FCC Rules. Operation is subject to the following two conditions: (1) this device may not cause harmful interference, and (2) this device must accept any interference received, including interference that may cause undesired operation.</p> <p>For questions related to the EMC performance of this product, contact:</p> <p style="padding-left: 40px;">Intel Corporation 5200 N.E. Elam Young Parkway Hillsboro, OR 97124 1-800-628-8686</p> <p>This equipment has been tested and found to comply with the limits for a Class A digital device, pursuant to Part 15 of the FCC Rules. These limits are NOT designed to provide reasonable protection against harmful interference in a residential installation. This equipment generates, uses, and can radiate radio frequency energy and, if not installed and used in accordance with the instructions, may cause harmful interference to radio communications. However, there is no guarantee that interference will not occur in a particular installation. If this equipment does cause harmful interference to radio or television reception, which can be determined by turning the equipment off and on, the user is encouraged to try to correct the interference by one or more of the following measures:</p> <p>Reorient or relocate the receiving antenna.</p> <p>Increase the separation between the equipment and the receiver.</p> <p>Connect the equipment to an outlet on a circuit other than the one to which the receiver is connected.</p> <p>Consult the dealer or an experienced radio/TV technician for help.</p>
<p>CANADA</p>	<p>INDUSTRY CANADA (Class A)</p> <p>This Class A digital apparatus complies with Canadian ICES-003.</p> <p>Cet appareil numérique de la classe A est conforme à la norme NMB-003 du Canada.</p>
<p>EUROPE</p>	<p>CE Declaration of Conformity</p> <p>This product has been tested in accordance to, and complies with the European Low Voltage Directive (73/23/EEC) and European EMC Directive (89/336/EEC). The product has been marked with the CE Mark to illustrate its compliance.</p>

continued

Table 11. Regional EMC Compliance Information (continued)

Country	Compliance Information
<p>JAPAN</p>	<p>VCCI (Class A)</p> <div data-bbox="548 323 1089 426" style="border: 1px solid black; padding: 5px;"> <p>この装置は、情報処理装置等電波障害自主規制協議会（VCCI）の基準に基づくクラスA 情報技術装置です。この装置を家庭環境で使用すると電波妨害を引き起こすことがあります。この場合には使用者が適切な対策を講ずるよう要求されることがあります。</p> </div> <p>English translation of the notice above is as follow: This is a Class A product based on the standard of the Voluntary Control Council For Interference (VCCI) from Information Technology Equipment. If this is used near a radio or television receiver in a domestic environment, it may cause radio interference. Install and use the equipment according to the instruction manual.</p>
<p>TAIWAN</p>	<p>BSMI Certification Information</p> <p>The following BSMI Certification Number is marked on the product:</p> <div data-bbox="537 684 842 747" style="border: 1px solid black; padding: 5px;"> <p>檢磁 3912I905</p> </div> <p>The following BSMI EMC Warning is marked on the product: BSMI Cert No and EMC Warning are required for Class A products</p> <div data-bbox="537 825 979 930" style="border: 1px solid black; padding: 5px;"> <p>警告使用者： 這是甲類的資訊產品，在居住的環境中使用時，可能會造成射頻干擾，在這種情況下，使用者會被要求採取某些適當的對策</p> </div>
<p>KOREA</p>	<p>RRL Certification Information</p> <div data-bbox="537 982 748 1037" style="border: 1px solid black; padding: 5px;">  <p>1. 기기의 명칭 (모델명): 2. 인증기관: 3. 인증받은 자의 상호: 4. 제조년월일: 5. 제조지/제조국가:</p> </div> <p>The English translation for the above is as follows:</p> <ol style="list-style-type: none"> 1. Type of Equipment (Model Name): SC5200 Hot-Swap, Redundant Power Server Chassis 2. Certification No.: Contact Intel representative 3. Name of Certification Recipient: Intel Corporation 4. Date of Manufacturer: Refer to date code on product 5. Manufacturer / Nation: Intel / Refer to manufacturing label on product

Product Ecology Documentation

Disposal Considerations

This product contains the following materials that may be regulated upon disposal:

Battery: see page 22.

Lead solder: any circuit boards in the system might contain lead solder.

Intel encourages its customers to recycle its products and their components (such as batteries and boards) whenever possible. In the US, a list of recyclers in your area can be found at: <http://www.eiae.org>. In the absence of a viable recycling option, products and their components must be disposed of in accordance with all applicable local environmental regulations.

A Equipment Log and Worksheets

Equipment Log

Use the blank equipment log provided here to record information about your server. You will need some of this information when you run the SSU.

Item	Manufacturer Name and Model Number	Serial Number	Date Installed
Chassis			
Server Board			
Processor Speed and Cache			
Memory			
Video Display			
Keyboard			
Mouse			
Diskette Drive A			
CD-ROM Drive			
Additional 5.25" Peripheral			
Hard Disk Drive			
Hard Disk Drive			
Hard Disk Drive			
Hard Disk Drive			
Hard Disk Drive			
Hard Disk Drive			
Hard Disk Drive			

continued

Current Usage

Calculating Power Usage

The total combined wattage for your configuration **must be less than the wattage rating for your power supply**. Use the two worksheets in this section to calculate the total used by your configuration. For current and voltage requirements of add-in boards and peripherals, see your vendor documents.

Worksheet, Calculating DC Power Usage

Table 12. Power Usage Worksheet 1

Device	Current (maximum) at voltage level:					
	+3.3 V	+5 V	-5 V	+12 V	-12 V	5 V standby
Baseboard and Front Panel board						
Fans				5 A		
Processor(s)						
Memory						
3.5-inch diskette drive						
CD-ROM drive						
Second 5.25-inch device						
Third 5.25-inch device						
1st hard drive						
2nd hard drive						
3rd hard drive						
4th hard drive						
5th hard drive						
6th hard drive						
SCSI Backplane		0.75 A				
Expansion Board 1						
Expansion Board 2						
Expansion Board 3						
Expansion Board 4						
Expansion Board 5						
Expansion Board 6						
Expansion Board 7						
Total Current						

Worksheet, Total Combined Power Used by the Server

1. From the previous worksheet, enter the total current for each column.
2. Multiply the voltage by the total current to get the total wattage for each voltage level.
3. Add the total wattage for each voltage level to arrive at the total combined power usage for the power subsystem.

Table 13. Power Usage Worksheet 2

Voltage level and total current (V X A = W)	Total Watts for each voltage level
(+3.3 V) X (_____ A)	_____ W
(+5 V) X (_____ A)	_____ W
(-5 V) X (_____ A)	_____ W
(+12 V) X (_____ A)	_____ W
(-12 V) X (_____ A)	_____ W
(5 V standby) X (_____ A)	_____ W
Total Combined Wattage	_____ W



CAUTION

Do not exceed a combined power output of 120 watts for the +5 V and +3.3 V outputs. Exceeding a combined 120 watts will overload the power subsystem and may cause the power supplies to overheat and malfunction.

B Warranty

Limited Warranty for Intel® Chassis Subassembly Products

Intel warrants that the Products (defined herein as the Intel® chassis subassembly and all of its various components and software delivered with or as part of the Products) to be delivered hereunder, if properly used and installed, will be free from defects in material and workmanship and will substantially conform to Intel's publicly available specifications for a period of three (3) years after the date the Product was purchased from an Intel authorized distributor. Software of any kind delivered with or as part of products is expressly provided "as is" unless specifically provided for otherwise in any software license accompanying the software.

If any Product furnished by Intel which is the subject of this Limited Warranty fails during the warranty period for reasons covered by this Limited Warranty, Intel, at its option, will:

- **REPAIR** the Product by means of hardware and/or software; OR
- **REPLACE** the Product with another Product; OR
- **REFUND** the then-current value of the Product if Intel is unable to repair or replace the Product.

If such Product is defective, transportation charges for the return of Product to buyer within the USA will be paid by Intel. For all other locations, the warranty excludes all costs of shipping, customs clearance, and other related charges. Intel will have a reasonable time to make repairs or to replace Product or to refund the then-current value of the Product.

In no event will Intel be liable for any other costs associated with the replacement or repair of Product, including labor, installation or other costs incurred by buyer.

This Limited Warranty, and any implied warranties that may exist under state law, apply only to the original purchaser of the Product.

Extent of Limited Warranty

Intel does not warrant that Products to be delivered hereunder, whether delivered stand-alone or integrated with other Products, including without limitation semiconductor components, will be free from design defects or errors known as "errata". Current characterized errata are available upon request.

This Limited Warranty does not cover damages due to external causes, including accident, problems with electrical power, usage not in accordance with product instructions, misuse, neglect, alteration, repair, improper installation, or improper testing.

Warranty Limitations and Exclusions

These warranties replace all other warranties, expressed or implied including, but not limited to, the implied warranties of merchantability and fitness for a particular purpose. Intel makes no expressed warranties beyond those stated here. Intel disclaims all other warranties, expressed or implied including, without limitation, implied warranties of merchantability and fitness for a particular purpose. Some jurisdictions do not allow the exclusion of implied warranties, so this limitation may not apply.

All expressed and implied warranties are limited in duration to the limited warranty period. No warranties apply after that period. Some jurisdictions do not allow limitations on how long an implied warranty lasts, so this limitation may not apply to you.

Limitations of Liability

Intel's responsibility under this, or any other warranty, implied or expressed, is limited to repair, replacement or refund, as set forth above. These remedies are the sole and exclusive remedies for any breach of warranty. Intel is not responsible for direct, special, incidental, or consequential damages resulting from any breach of warranty under another legal theory including, but not limited to, lost profits, downtime, goodwill, damage to or replacement of equipment and property, and any costs of recovering, reprogramming, or reproducing any program or data stored in or used with a system containing this product. Some jurisdictions do not allow the exclusion or limitation of incidental or consequential damages, so the above limitations or exclusions may not apply to you.

This limited warranty gives you specific legal rights, and you may also have other rights that vary from jurisdiction to jurisdiction.

Any and all disputes arising under or related to this Limited Warranty shall be adjudicated in the following forums and governed by the following laws: for the United States of America, Canada, North America and South America, the forum shall be Santa Clara, California, USA and the applicable law shall be that of the State of California, USA; for the Asia Pacific region, the forum shall be Singapore and the applicable law shall be that of Singapore; for Europe and the rest of the world, the forum shall be London and the applicable law shall be that of the United Kingdom.

In the event of any conflict between the English language version and any other translated version(s) of this Limited Warranty, the English language version shall control.

How to Obtain Warranty Service

To obtain warranty service for this Product, you may contact Intel or your authorized distributor.

North America—Call Intel at 1-800-628-8686 during the warranty period during normal business hours (Pacific Time), excluding holidays. Please be prepared to provide: (1) your name, address, and telephone numbers; (2) model name and serial number of the Product; (3) an explanation of the problem. The customer service representative may need additional information from you depending on the nature of the problem.

In Europe, Asia, or South America—Contact your original authorized distributor for warranty service.

Any replacement Product is warranted under this written warranty and is subject to the same limitations and exclusions for the remainder of the original warranty period.

Telephone Support

All calls are billed US \$25.00 per incident, levied in local currency at the applicable credit card exchange rate plus applicable taxes.

In U.S. and Canada		1-800-404-2284	
In Europe			
UK	0870 6072439	Finland	9 693 79297
France	01 41 918529	Denmark	38 487077
Germany	069 9509 6099	Norway	23 1620 50
Italy	02 696 33276	Sweden	08 445 1251
Spain	91 377 8166	Holland	020 487 4562
In Asia-Pacific region			
Australia	1800 649931	Indonesian	001-803 65 7249
Hong Kong	852 2 844 4456	Malaysia	1-800 80 1390
Korea	822 767 2595	New Zealand	0800 444 365
PRC	800 820 1100	Pakistan	632 6368415
Singapore	65 831-1311	Philippines	1-800 1 651 0117
Taiwan	2 2718 9915	Thailand	001-800 6310003
India	0006517-2-830 3634	Vietnam	632 6368416
In Japan			
0120-868686 (Domestic)		81-298-47-0800 (outside country)	
In Latin America			
Brazil	0021-0811-408-5540	Ecuador	999-119, 800-628-8686 (via AT&T)
Mexico	001-800-628-8686	Guatemala	99-99-190, 800-628-8686 (via AT&T)
Colombia	980-9-122-118	Venezuela	800-11-120, 800-628-8686 (via AT&T)
Costa Rica	0-800-011-0395	Argentina	001-800-222-1001, 800-628-8686 (via AT&T)
Panama	001-800-628-8686	Paraguay	008-11, 800-628-8686 (via AT&T)
Chile	800-532-992	Peru	0-800-50000, 800-628-8686 (via AT&T)
Miami	1-800-621-8423	Uruguay	000-410, 800-628-8686 (via AT&T)

Returning a Defective Product

Before returning any product, call your authorized dealer/distribution authority. If the customer support group verifies that your product is defective, you will receive a Return Material Authorization (RMA) number to place on the outer package of the product. Intel can not accept any product without an RMA number on the package.