

The Intel® WiMAX Connection 2250

The Intel® WiMAX Connection 2250 is an integrated WiMAX system on chip (SoC) that is optimized for cost-effective WiMAX modems and offers flexibility in equipment design, deployment, and application.

The Intel WiMAX Connection 2250 is compliant with both IEEE 802.16-2004 and IEEE 802.16e-2005 specifications. The dual-specification support is enabled by a software-configurable modem that operates as an OFDM 256 PHY (for IEEE-802.16-2004 mode) or an OFDMA PHY (for IEEE 802.16e-2005 mode). This unique feature enables development of customer premise equipment (CPE) that can be deployed in “d” mode and upgraded to “e” mode—enabling unmatched versatility, time to market, and investment protection.

Versatility and investment protection is further enhanced by the Intel WiMAX Connection 2250 processor’s backward compatibility with the Intel® PRO/Wireless 5116 broadband interface. The Intel WiMAX Connection 2250 uses the same package and pin layout—and supports a firmware/software load that provides the same functionality as the Intel PRO/Wireless 5116 broadband interface. This architecture allows existing WiMAX-certified designs based on the Intel PRO/Wireless 5116 broadband interface to be quickly modified to host existing “d” mode implementations while also providing “e” mode upgrade capability.

When combined with the Intel® WiMAX Multi-Band Radio or third-party RFICs, the Intel WiMAX Connection 2250 enables manufacturers to create a broad range of WiMAX modems and residential gateways. These self-installed products are well-suited to both indoor and outdoor applications and provide support for channel bandwidths up to 10 MHz. The wide range of applications and regulatory domains provides an essential foundation for delivering high-rate, IP-based data, voice, and real-time video.

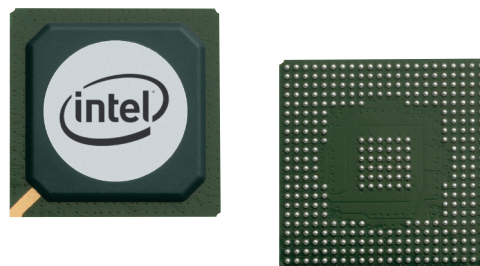

Two integrated ARM® 946E-S processors provide processing power that allows management and other layer-three networking applications to run on-chip, without need for an external applications processor. An integrated IEEE 802.3 Fast Ethernet Controller and security accelerator contribute to high performance at low cost. To further reduce cost, Intel WiMAX Connection 2250 hardware implementations are expected to be available through several third-party ODMs.

Included with the Intel WiMAX Connection 2250 are software development kits (SDKs) for both IEEE 802.16-2004 and IEEE 802.16e-2005 modes, providing developers with the necessary tools to harness the device’s programmability.

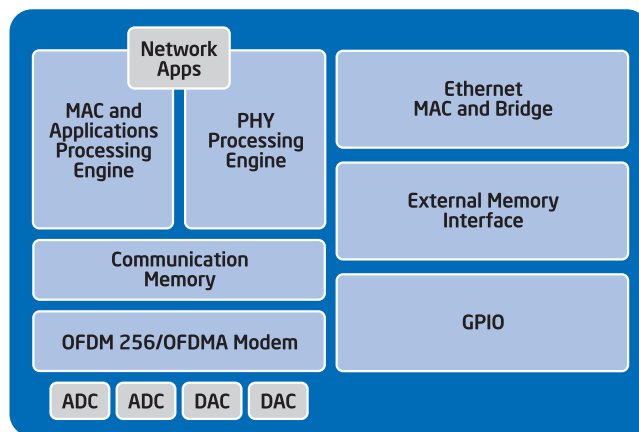

Figure 1: Intel® WiMAX Connection 2250 High-Level Block Diagram

Intel® WiMAX Connection 2250 Key Features/Highlights

Modem (802.16-2004 Mode)

- OFDM 256 PHY mode with support for channel bandwidths up to 10 MHz
- TDD and H/FDD duplexing modes
- Concatenated Reed-Solomon and Convolutional Encoding Forward Error Correction
- Adaptive modulation (BPSK, QPSK, QAM16, QAM64)
- Enhanced link budget support
 - Receive space time coding
 - Uplink sub-channelization
 - SNR, RSSI channel quality measurements
 - Switched diversity
 - ARQ

Modem (802.16e-2005 Mode)

- OFDMA 512/1024 PHY mode with support for channel bandwidths up to 10 MHz
- Support for TDD and H/FDD duplexing modes
- PUSC with all subchannels and dedicated pilots, FUSC, AMC 2x3 for AAS Beam Forming support
- Concatenated Reed-Solomon and Convolutional Encoding Forward Error Correction
- Adaptive modulation (BPSK, QPSK, QAM16, QAM64)
- Enhanced link budget support
 - 2-channel matrix A MIMO support
 - Uplink/Downlink sub-channelization
 - SNR, RSSI channel quality measurements
 - Switched diversity
 - ARQ, HARQ
 - AAS/Beam Forming

MAC (802.16e-2005 Mode)

- Payload Header Suppression
- IPv4, IPv6, 802.3 Convergence Sub-Layers
- ARQ, HARQ
- UGS, RT-VR, NRT-VR, ERT-VR, and BE QoS classes
- Sleep and Idle mode power management support
- 802.16 Authorization Policy and EAP Authorization

Processing

- Dual-core ARM* 946E-S engines for PHY, MAC, and application protocol processing
- Highly optimized DSP engine with multiple parallel ALUs for concurrent complex operations per cycle, which enables efficient OFDM/OFDMA processing
- In-line security processing using advanced encryption techniques (3DES, AES, and RC4)

I/O and Interfaces

- Modular RF interface supporting I/F or baseband I/Q radios designed for WiMAX licensed and unlicensed spectrum
- Integrated pair of ADCs and DACs and a high-performance PLL to drive converters
- Integrated 10/100 Ethernet MAC with MII interface to external PHY
- SPI and memory interfaces for VoIP SoC Integration
- Additional I/O and system interfaces
 - Extended memory interfaces—SDRAM and flash
 - Test and debug interfaces
 - Programmable GPIOs

Packaging and Thermals

- 360-pin industrial-grade PBGA supporting temperatures ranging from -40° C to 85° C

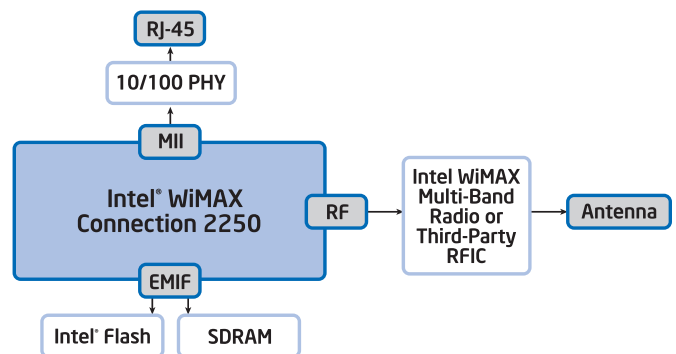

Figure 2: Intel® WiMAX Connection 2250 CPE System Diagram

INFORMATION IN THIS DOCUMENT IS PROVIDED IN CONNECTION WITH INTEL® PRODUCTS. EXCEPT AS PROVIDED IN INTEL'S TERMS AND CONDITIONS OF SALE FOR SUCH PRODUCTS, INTEL ASSUMES NO LIABILITY WHATSOEVER, AND INTEL DISCLAIMS ANY EXPRESS OR IMPLIED WARRANTY RELATING TO SALE AND/OR USE OF INTEL PRODUCTS, INCLUDING LIABILITY OR WARRANTIES RELATING TO FITNESS FOR A PARTICULAR PURPOSE, MERCHANTABILITY, OR INFRINGEMENT OF ANY PATENT, COPYRIGHT, OR OTHER INTELLECTUAL PROPERTY RIGHT. INTEL MAY MAKE CHANGES TO SPECIFICATIONS, PRODUCT DESCRIPTIONS, AND PLANS AT ANY TIME, WITHOUT NOTICE.

Intel Corporation may have patents or pending patent applications, trademarks, copyrights, or other intellectual property rights that relate to the presented subject matter. The furnishing of documents and other materials and information does not provide any license, express or implied, by estoppel or otherwise, to any such patents, trademarks, copyrights, or other intellectual property rights. Intel products are not intended for use in medical, life saving, life sustaining, critical control or safety systems, or in nuclear facility applications. The Intel® WiMAX Connection 2250 may contain design defects or errors known as errata, which may cause the product to deviate from published specifications. Current characterized errata are available upon request.

*Other names and brands may be claimed as the property of others.

Copyright © 2006 Intel Corporation. All rights reserved. Intel, the Intel logo, Intel. Leap ahead. and Intel. Leap ahead. logo are trademarks or registered trademarks of Intel Corporation or its subsidiaries in the United States and other countries.

Printed in USA/1006/SS/PMS/PDF Order Number: 307327-002US

