

White Paper  
Intel Information Technology  
Computer Manufacturing  
Data Center Efficiency

# Increasing Data Center Efficiency through Metering and Monitoring Power Usage

To increase data center energy efficiency at one of our older data centers in India, Intel IT's Data Center Services group collaborated on a technology study with the IT compute organization and Intel Facilities Management to develop a comprehensive approach to metering power usage. We developed methods for identifying measurable efficiency improvements and placed instrumentation to continuously track power usage effectiveness (PUE), the key metric of data center energy efficiency. Using PUE metrics allowed us to make decisions that increased efficiency, helped achieve optimum data center facility utilization, and provided data we can share with other Intel facilities around the world to proliferate energy savings.

Anand Vanchi, Sujith Kannan, and Ravi Giri, Intel Corporation

June 2009

IT@Intel

## Executive Summary

To increase energy efficiency at a five-year-old data center in India, Intel IT's Data Center Services group, the IT compute organization, and Intel Facilities Management collaborated to develop a consistent way to measure data center energy efficiency—including return on investment (ROI), IT performance, and facility utilization. Our integrated approach for measuring total IT power utilization involved metering power usage at the granularity of a row of servers.

**We developed a clear, consistent way to measure data center efficiency—including ROI, IT performance, and facility utilization.**

Energy is the highest operating cost in our data centers, and Intel IT faces the challenge of supporting ever increasing electrical energy consumption for design engineering and enterprise computing. To address these concerns at our data center in India, which was built on older design principles, we developed methods to identify efficiency improvements and implemented instrumentation to continuously track power usage effectiveness (PUE) and data center efficiency (DCE).

These metrics delivered actionable inputs that helped improve energy efficiency, saving resources at this and other Intel facilities in India. By defining the diminishing returns of a narrow focus on facilities management and on improving the PUE of the data center, the metrics also reinforced the need to focus on overall IT performance efficiency to achieve greater long-term ROI for data center efficiency efforts.

Close collaboration between Data Center Services, the IT compute organization, and Intel Facilities Management throughout the project life cycle led to greater savings than originally anticipated, as we could measure each variable with a potential impact on electrical energy consumption. This integrated approach enabled us to chart a future course of action for the data center's energy efficiency roadmap.

Improving the PUE index of this data center from 1.99 in 2007 to 1.81 in 2008 provided performance and financial benefits including:

- Annual energy cost savings of USD 77,000 for a data center with an average load of 9,672 kilowatt-hours (kWh) per day
- 10 percent improvement in overall operational efficiency
- Detailed return on investment (ROI) justification for retrofitting the data center to further improve rack power density by 2.8x, from 5 kilowatts (kW) per rack to 14 kW per rack

Based on the success of this initiative, the project team has become a key contributor in the Intel IT Global Data Center Manageability work group. This work group addresses metering, monitoring, and efficiency requirements at Intel IT data centers around the world, helping to proliferate a collaborative strategy for an enterprise-wide "single pane of glass" view into data center manageability. An integrated IT-Facilities point of view will help us manage and correlate capacity and utilization.

# Contents

<b>Executive Summary</b> .....	2
<b>Business Challenge</b> .....	4
<b>Solution</b> .....	5
Building a Collaborative Team.....	5
Defining the Project.....	5
Addressing Business Value Considerations.....	5
Establishing Baseline Measurements and Improvement Goals.....	5
Implementing the Solution.....	8
Results.....	9
Next Steps.....	10
<b>Conclusion</b> .....	11
<b>Authors</b> .....	12
<b>Acknowledgements</b> .....	12
<b>Acronyms and Terms</b> .....	12

## Business Challenge

Energy consumption is a critical concern for IT organizations worldwide as the cost of operating data centers increases due to the growing use of computing devices and rising energy costs. Compounding these factors, data centers that were considered state of the art just five years ago are now lagging behind in energy-efficient technologies.

Intel IT has taken significant steps to reduce its environmental impact, especially in data centers, where energy is a top operating cost. As part of these efforts, Intel IT's Data Center Services group developed a collaborative strategy with the IT compute organization and Intel Facilities Management to meter and monitor data center power usage at a five-year-old data center in India. While Intel has a number of state-of-the-art data centers with aggressive power usage effectiveness (PUE) numbers, we also needed to look at cost-effective ways to update our older data centers—which, as for most companies, represent the highest percentage of data centers currently in operation.

The challenges we faced at this older data center were multifaceted:

- Computing demands from Intel product groups were getting more complex.

- India, like other emerging economies, was witnessing a widening gap between supply and demand for power resources.
- Available systems to measure data center efficiency were intensely manual, error prone, and limited to a single point in time.
- Available energy consumption data was residing in multiple, disparate systems across the IT and facilities organizations.

All of these factors made it difficult to measure electrical energy consumption in the data center and take specific actions to reduce consumption. Furthermore, some of the infrastructure systems, such as the chiller plant, were shared between the data center and other facility needs, hampering targeted measurements.

### India's Data Center Efficiency Initiative

As India plans to be the world's first market for trading in energy savings, the Government of India has formed a national policy group to focus on data center energy efficiency and to develop a National Design Code for Energy Conservation in Data Centers and a Best Practice Manual for Indian Data Centers in consultation with industry. As part of our commitment to IT sustainability, Intel IT is an active participant in this group.

# Solution

Through a collaborative process, we improved energy efficiency at our five-year-old India data center by metering and monitoring electrical energy consumption at a very granular level, achieved through implementing instrumentation that enabled continuous tracking of PUE, the key data center efficiency metric. Metering facility utilization for power, cooling, and losses at key points in power distribution provided practical information for implementing efficiency improvements.

## Building a Collaborative Team

It was critical for stakeholders—Data Center Services, IT computing, and Facilities Management—to collaborate throughout the project life cycle so that we could measure each variable that had a potential impact on energy consumption and have a holistic view of total facility operating costs.

## Defining the Project

The primary goal of this project was to target potential cost saving opportunities. We focused on identifying current operational costs, setting baseline measurements, implementing energy efficiency processes based on the information we gathered, and moving toward our defined goal. Once we implemented our project, we would continue to measure and make improvements.

## Addressing Business Value Considerations

Having consistent methods for measuring data center efficiency (DCE) that encompassed important business factors like return on investment (ROI), IT performance, and facility utilization was critical in helping us to address challenges such as:

- Rightsizing facility infrastructure and considering appropriate load diversity.
- Increasing the efficiency of the uninterruptible power supply (UPS) system.
- Reducing power consumption for data center cooling.
- Designing the optimum power and cooling distribution architecture within the data center.

- Eliminating redundancies to align facilities with business needs.
- Determining plans for legacy servers, which yield lower performance per watt of power consumed compared to current servers based on multi-core processors.
- Dealing with geographic factors, such as humidity, temperature, utility reliability, and so on.

Once we completed all of our analysis and planning, we were ready to start metering energy consumption.

## Establishing Baseline Measurements and Improvement Goals

Our older India data center is a 5500-square-foot facility built on older design principles such as a 24-inch raised floor, a 10-foot-high false ceiling that is not used as a return air plenum, and no hot aisle containments. It has a power density of 110 watts per square foot (WPSF), a 2(N+1) UPS power redundancy configuration, and ductless chilled-water-based precision air conditioning (PAC) units in an N+1 cooling redundancy configuration.

## Determining a Process for Data Collection

Before we could begin metering, we needed to address a number of challenges in our older data center:

- Isolating data center power and cooling loads from the rest of the building facilities.

- Metering facility utilization—power, cooling, and losses—at the right points in the power distribution cycle so that we collected the most useful information for efficiency improvements.
- Identifying the optimum levels of granularity for energy metering.

To resolve these issues, we determined that we needed to implement energy meters at the row level in our older data center. This enabled us to distinguish between electrical energy consumption for IT equipment and for the rest of the building facilities, to meter and monitor total facility utilization at a very granular level to establish baseline metrics, and to continually track PUE, the key data center efficiency metric.

We also measured and analyzed all electrical energy consumption of the data center operation to gather accurate efficiency measurements. This meant identifying the optimum, comprehensive level of granularity for power and cooling metering by:

- Measuring existing energy efficiency levels.
- Identifying current operational power costs and setting the baseline.
- Targeting potential cost saving opportunities and setting the goals.
- Implementing the efficiency improvement process using the existing knowledge base.
- Continuously measuring and working on improvements in data center operational cost structures.

### Key Metric: Power Usage Effectiveness

We used calculations advocated by Green Grid\*, a global consortium dedicated to advancing energy efficiency in data centers and business computing ecosystems:

$$\text{Power usage effectiveness (PUE)} = \frac{\text{Total facility power}}{\text{Total IT equipment power}}$$

As seen in Figure 1, the reciprocal, data center efficiency, is defined as:

$$\text{Data center efficiency (DCE)} = \frac{1}{\text{PUE}} = \frac{\text{Total IT equipment power}}{\text{Total facility power}}$$

### Total facility power

Total facility power is defined as the power measured at the utility meter that is dedicated solely to the data center. Data center total facility power includes everything that supports the IT equipment load, such as:

- Power delivery components including UPSs, switch gears, generators, power distribution units (PDUs), batteries, and distribution losses external to the IT equipment
- Cooling system components such as chillers, computer room air conditioning (CRAC) units, direct expansion (DX) air handler units, pumps, cooling towers, and automation
- Compute, network, and storage nodes
- Other miscellaneous component loads, such as data center lighting, the fire protection system, and so on

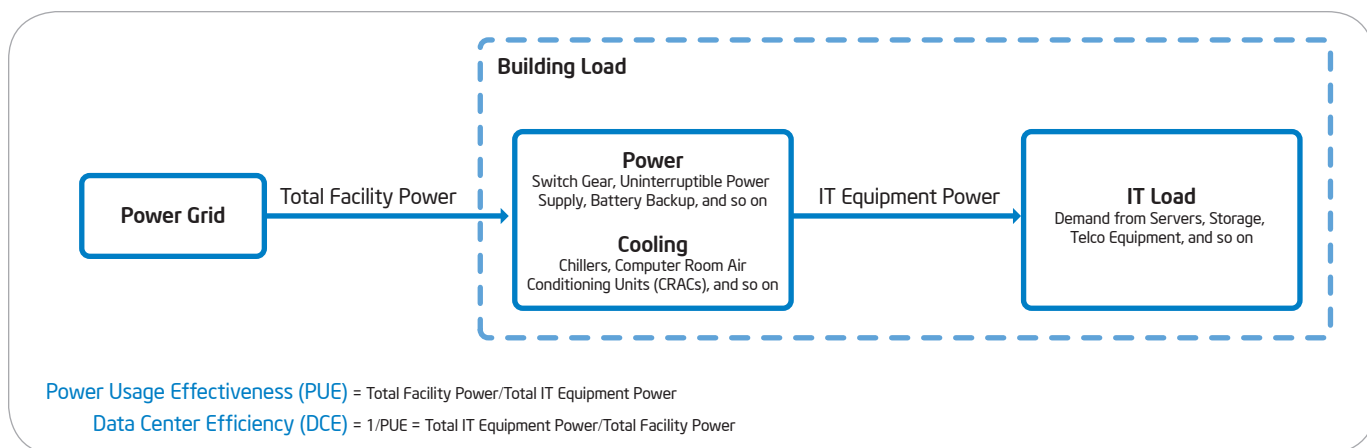

Figure 1. Identifying power metering points to capture IT utilization data.

Power measurement in mixed-use buildings—buildings that house data centers as one of several functions—requires metering to distinguish power used for the data center. Figure 2 shows our UPS power metering layout to measure total facility power in our older data center.

**IT equipment power**

IT equipment power is defined as the effective power used by the equipment that manages, processes, stores, or routes data within the raised floor space, including:

- The load associated with all of the IT equipment such as compute, storage, and network equipment
- Supplemental equipment such as keyboard, video, mouse (KVM) switches; monitors; and workstations and laptops used to monitor or otherwise control the data center

Typically, IT equipment power is monitored at the rack level using metered PDUs; however, we found a more effective approach by continuous monitoring at the row level in the electrical distribution box using these energy meters.

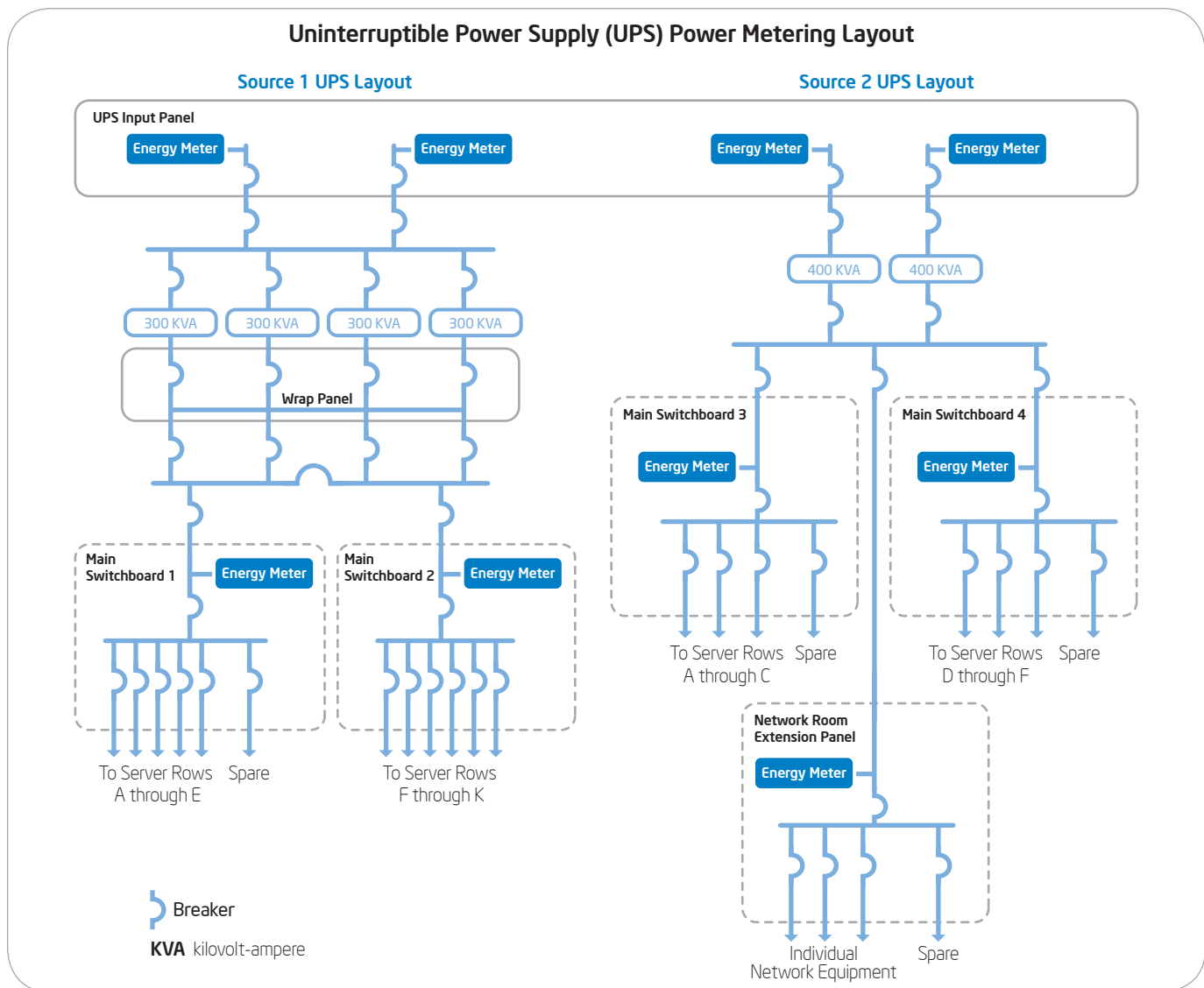

**Figure 2. Uninterruptible power supply (UPS) power metering measured the total facility power of the data center.**

**Table 1. Location of Data Center Power and Cooling Meters**

<b>Power metering</b>	<ul style="list-style-type: none"> <li>Input side: uninterruptible power supply (UPS) input panel</li> <li>Output side: row-level power distribution panel</li> </ul>
<b>Cooling metering</b>	<ul style="list-style-type: none"> <li>Precision air conditioning (PAC) units: at distribution panel supplying power to the PAC units</li> <li>Multi-use chiller plant: used flow meters and temperature sensors to isolate cooling consumption of the data center alone</li> </ul>

## Implementing the Solution

To monitor PUE in our older data center, we installed energy meters for measuring IT power loads. Because the chilled water plant was common between the data center, labs, and office space, we installed flow meters and temperature sensors along with regular energy meters to measure cooling loads. All of the meters were hooked up to the building management system (BMS) for more effective continuous availability of measurements. Table 1 describes the locations of the meters. Figure 3 shows the locations of energy meters to measure cooling.

## Collecting Measurements

We measured the following items for potential energy efficiency savings:

- UPS and distribution losses
- IT load electrical energy utilization
- Total electrical energy utilization by PAC units in the data center
- Electrical energy utilization for running make-up air units for the data center
- Electrical energy utilization for cooling the UPS room
- Electrical energy utilization at the chiller plant, with respect to data center usage
- Lighting load measurements

Granular measurements levels provided us with optimal metrics for tracking and monitoring electrical energy utilization. We rolled

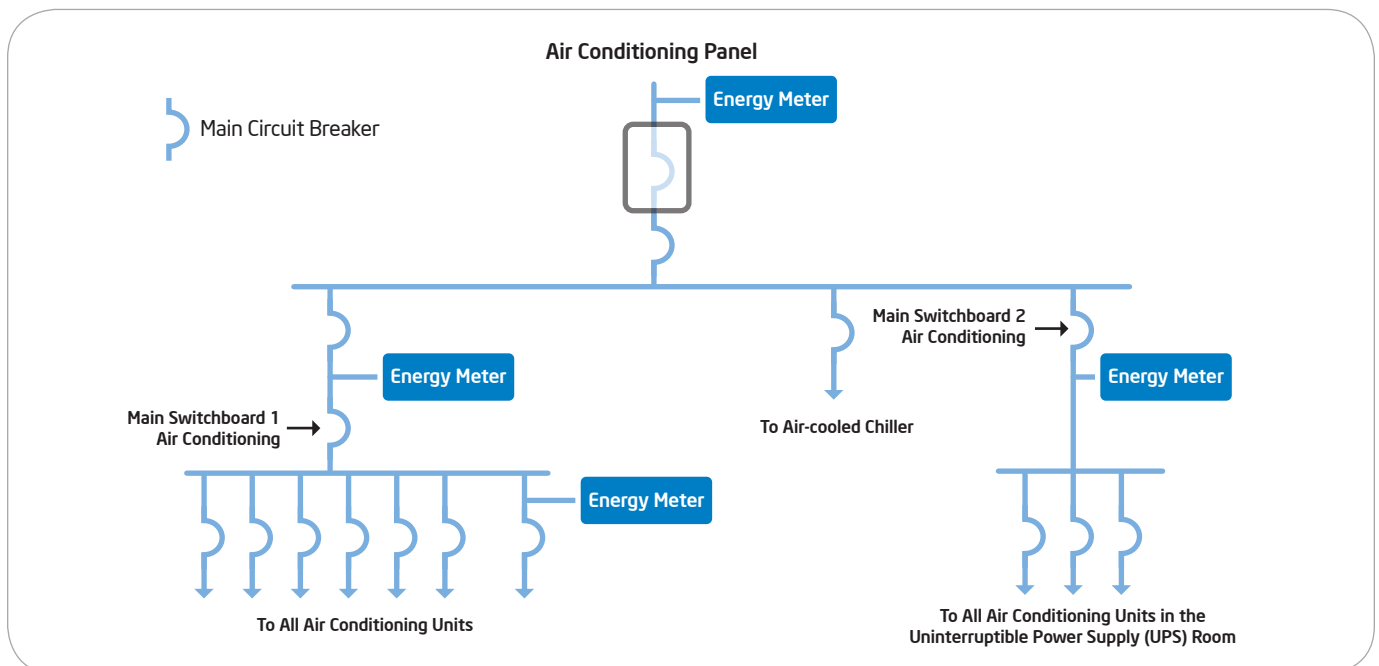

**Figure 3. Cooling power metering isolated data center power from the rest of the building facilities.**

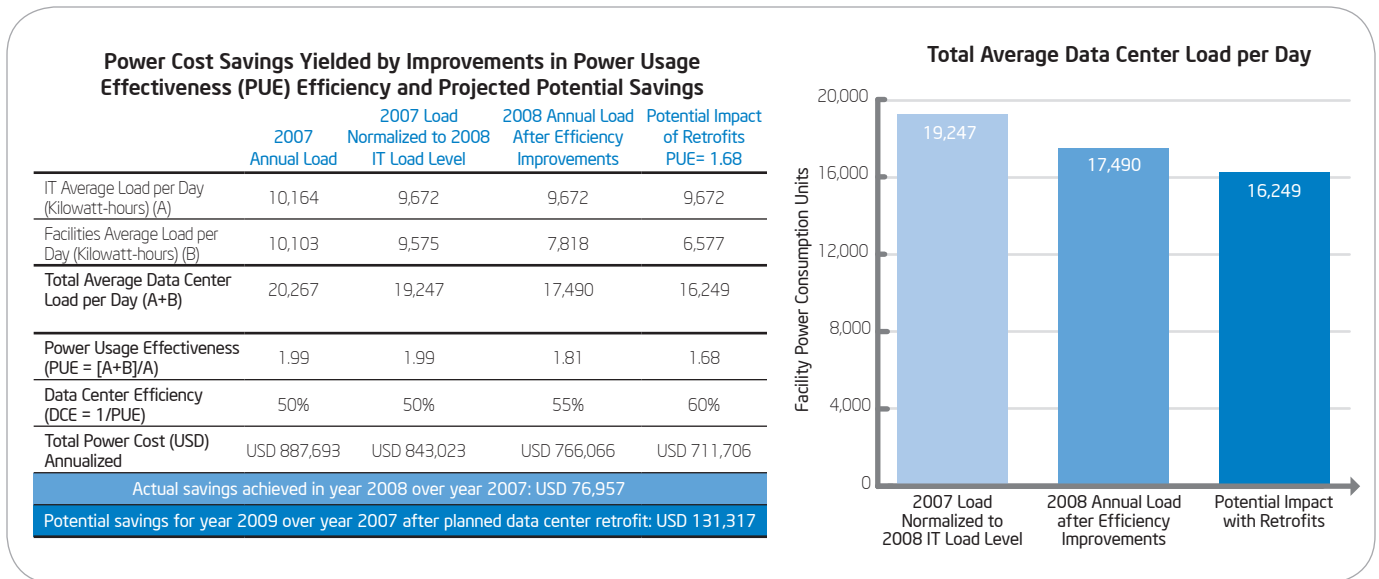

**Figure 4. Actual and projected savings from improving power usage effectiveness (PUE) in an older data center.**

out measurement activities at various times during the year, based on input received from continuous metering of the facility consumption in the data center.

### Analyzing Electrical Energy Utilization

We analyzed all electrical energy utilization of the data center operation to generate reports that would allow us to make modifications to the older data center. Reports included continuous PUE measurements, impact on PUE due to variation in IT load, and impact on PUE due to variation in facility utilization corresponding to variation in load.

### Modifying the Data Center

Based our measurements and analysis, we took a number of subsequent actions:

- Paralleling the UPS to increase the utilization levels, thereby increasing efficiency and reducing distribution losses.
- Increasing the PAC temperature set point from 19 to 23 degrees Celsius.
- Implementing humidity controls as needed; we found these controls were only required for three months of the year.
- Managing airflow inside the data center.
- Managing load spread across the data center floor.

- Using LED lighting for emergency lighting inside the data center.
- Managing standard lighting to reduce consumption.

Each of these actions required in-depth planning and coordinated execution. As part of our ongoing work to improve energy efficiency in our older data centers, we plan to share our experiences and best-known methods in future publications.

### Results

This facility efficiency program emphasized the importance of PUE as a metric and demonstrated how we could consistently measure and manage PUE in data centers to improve energy efficiency.

We achieved the following results, summarized in Figures 4 and 5:

- Annualized operational power cost savings of USD 77,000 and more than 10 percent improvement in overall operational data center efficiency in 2008 by improving PUE from 1.99 to 1.81.
- Identified the potential for further savings by implementing further retrofits: incremental savings of 20 percent by improving PUE to 1.68 and total annualized power cost savings of USD 131,000.

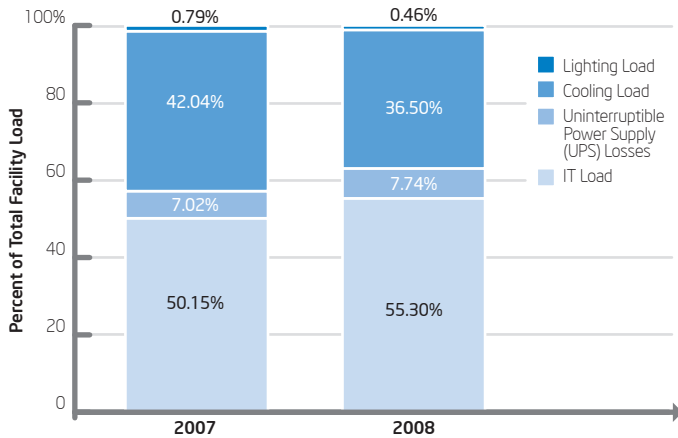
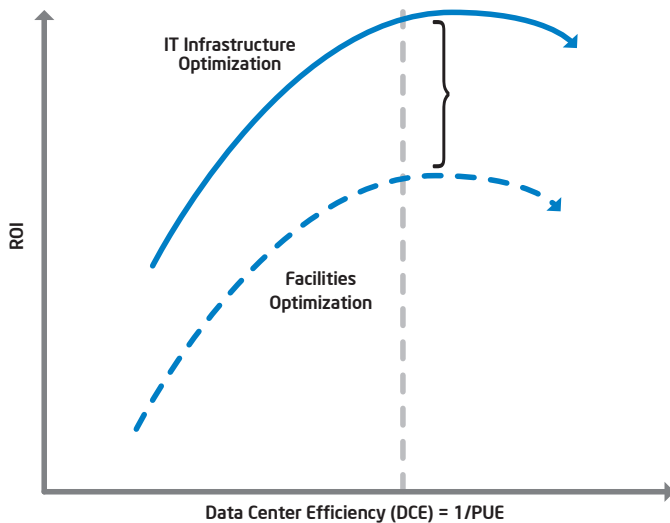

**Figure 5. Total facilities load reduction.** Despite an increase in the overall IT load, there has been a reduction in total facilities load.

- Established the relationship between power density optimization and improved efficiency.
- Contributed to the ROI justification for retrofitting the data center to a higher density and capacity, refreshing four-year-old servers based on single-core processors with high-performance, high-density servers based on multi-core processors.
- Proliferated knowledge we gained globally within the organization, including our contributions on data and architecture.

We learned the importance of collaborating to implement change, as well as to save resources and improve ROI through the development of a partnership between stakeholders in data center operations, the IT computing organization, and facilities management. Because the team worked together throughout the project life cycle, this integrated approach resulted in greater savings than originally anticipated, as we could consistently measure each variable that potentially impacted energy consumption.

The results of this project also stimulated the creation of a global work group focused on data center management and provided the initial ROI values and architectural approach for our worldwide effort. This work group will investigate, develop, and evaluate design options for integrating data center IT and facility asset management systems for performance optimization and enterprise-wide monitoring and management.



**Figure 6. Diminishing return on investment (ROI) for further improvements in power usage effectiveness (PUE).** For the same PUE, IT infrastructure optimization (less power for the same compute output) provides additional savings and is a natural next step in the efficiency improvement process.

## Next Steps

Through our study, we determined that the initial investment to improve the PUE from 1.99 to 1.81 was approximately USD 7,000. However, we also learned that efficiency gains from facilities optimization are finite: The reduction in facilities utilization cannot go on forever. While that doesn't mean the quest for higher DCE necessarily ends, we determined that further potential improvement in PUE to 1.68 would necessitate a much higher investment in retrofitting, estimated at several hundred thousand U.S. dollars.

Based on analysis of these findings, we could infer the key point in the diminishing return in ROI for every further step in improvement of PUE, as shown in the conceptual representation in Figure 6. We also learned that efficiency gains from facilities optimization are finite for any data center based on the geographical location, power and cooling distribution architecture, and other location-specific environmental factors.

We can potentially achieve further reductions in energy consumption and reach the next level in DCE through further team collaboration on IT infrastructure optimization, server refresh, and other efforts.

# Conclusion

At this data center, we demonstrated a 10 percent improvement in overall operational efficiency and achieved annual cost savings of USD 77,000, with potential for 2.8x improvement in rack power density. These results led to improved data center facility utilization and justified the ROI of transitioning to a higher density data center. This increase in rack power density allows us to take advantage of current generation high-performance multi-core server infrastructure—enabling higher compute capacity per watt of power consumed.

By taking an integrated, holistic approach and by analyzing all the factors associated with data center electrical energy usage and performance, we implemented changes that led to greater savings while developing metrics for repeatability and achieving optimum facility utilization levels at Intel data centers around the world. This study is the first step in establishing concise operating costs per unit of IT performance and in evolving the total cost of ownership (TCO) model to deliver effective data center services in the most efficient

way—from a Facilities Management perspective and an IT perspective.

This combined IT-Facilities perspective that guided our work also led Intel to develop an enterprise-wide view of data center manageability—a “single pane of glass.” This integrated view of utilization will help manage IT capacity and cost.

Our focus in the future will be to correlate IT performance and facility utilization and the benefits we can derive long term.

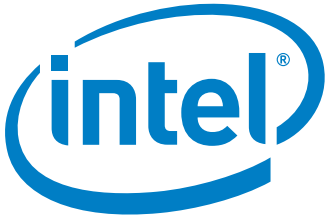

For additional content on Intel IT's best practices on this topic, go to [www.intel.com/it](http://www.intel.com/it)

## Authors

Anand Vanchi is an enterprise architect with Intel IT.

Sujith Kannan is the maintenance and operations manager for Intel India.

Ravi Giri is a staff engineer with Intel IT.

## Acknowledgements

Ravi Madras is a data center operations manager with Intel IT.

Rajkumar Kamar is a data center operations manager with Intel IT.

Ashok Radhakrishnan is the IT Sustainability India program manager.

## Acronyms and Terms

BMS	building management system
CRAC unit	computer room air conditioning unit
DX	direct expansion
DCE	data center efficiency: $1/PUE$ or total IT equipment power / total facility power
facility utilization	total data center electrical energy consumption: power, cooling, and losses
IT equipment power	the effective power directly used by the equipment that manages, processes, stores, or routes data within the raised floor space, such as server, storage, and network equipment
KVA	kilovolt-ampere
KVM	keyboard, video, or mouse
PAC unit	precision air conditioning unit
PDU	power distribution unit
PUE	power usage effectiveness: a metric advocated by Green Grid that is equal to total facility power / total IT equipment power
ROI	return on investment
TCO	total cost of ownership
total facility power	total facility power consumption, which includes all the power used to support the data center
UPS	uninterruptible power supply

This paper is for informational purposes only. THIS DOCUMENT IS PROVIDED "AS IS" WITH NO WARRANTIES WHATSOEVER, INCLUDING ANY WARRANTY OF MERCHANTABILITY, NONINFRINGEMENT, FITNESS FOR ANY PARTICULAR PURPOSE, OR ANY WARRANTY OTHERWISE ARISING OUT OF ANY PROPOSAL, SPECIFICATION OR SAMPLE.

Intel disclaims all liability, including liability for infringement of any proprietary rights, relating to use of information in this specification. No license, express or implied, by estoppel or otherwise, to any intellectual property rights is granted herein.

Intel and the Intel logo are trademarks of Intel Corporation in the U.S. and other countries.

\*Other names and brands may be claimed as the property of others.

Copyright © 2009 Intel Corporation. All rights reserved.

Printed in USA  
0609/KAR/KC/PDF

Please Recycle  
322018-002US