

<i>Mario Pasquali - Ecole d'Ingénieurs de Genève</i>		
Title Scope - Architecture		
Size A4	Document Number 1.0	Rev 0
Date:	Wednesday, September 15, 1999	Sheet 1 of 1

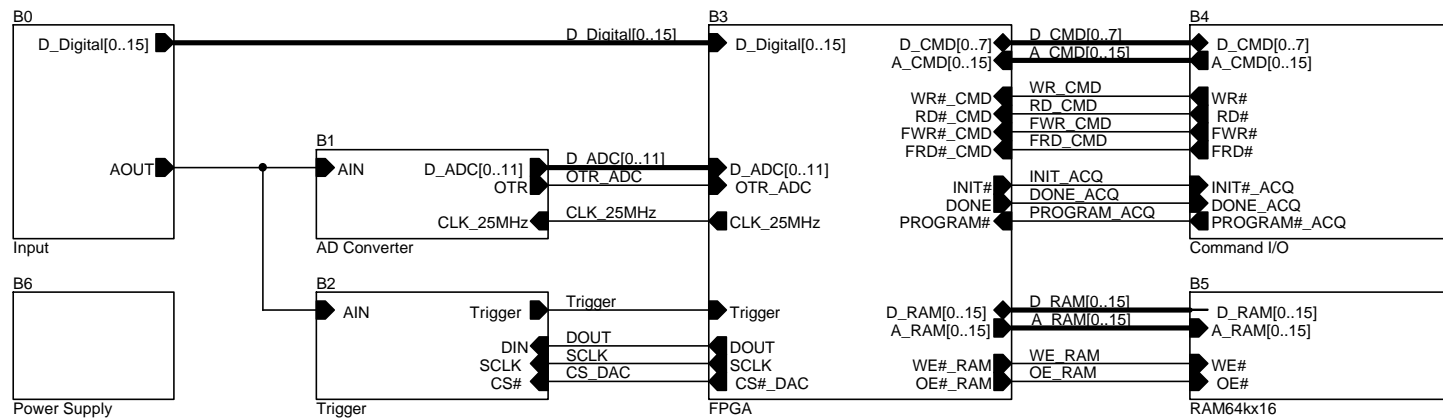

<i>Mario Pasquali - Ecole d'Ingénieurs de Genève</i>		
Title		
Scope - Acquisition Board - Main		
Size	Document Number	Rev
A4	1.0	0
Date:	Wednesday, September 15, 1999	Sheet 1 of 8

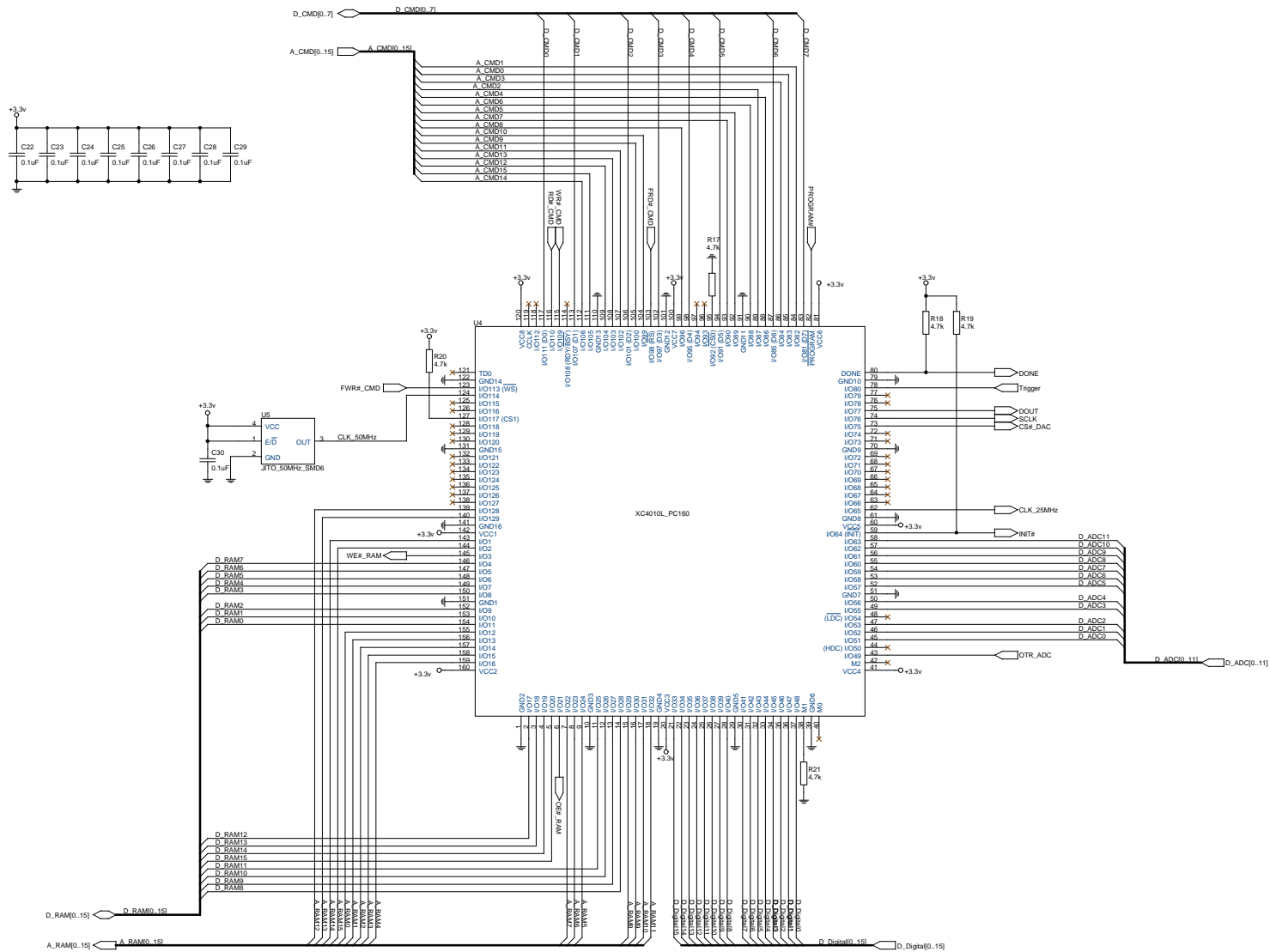

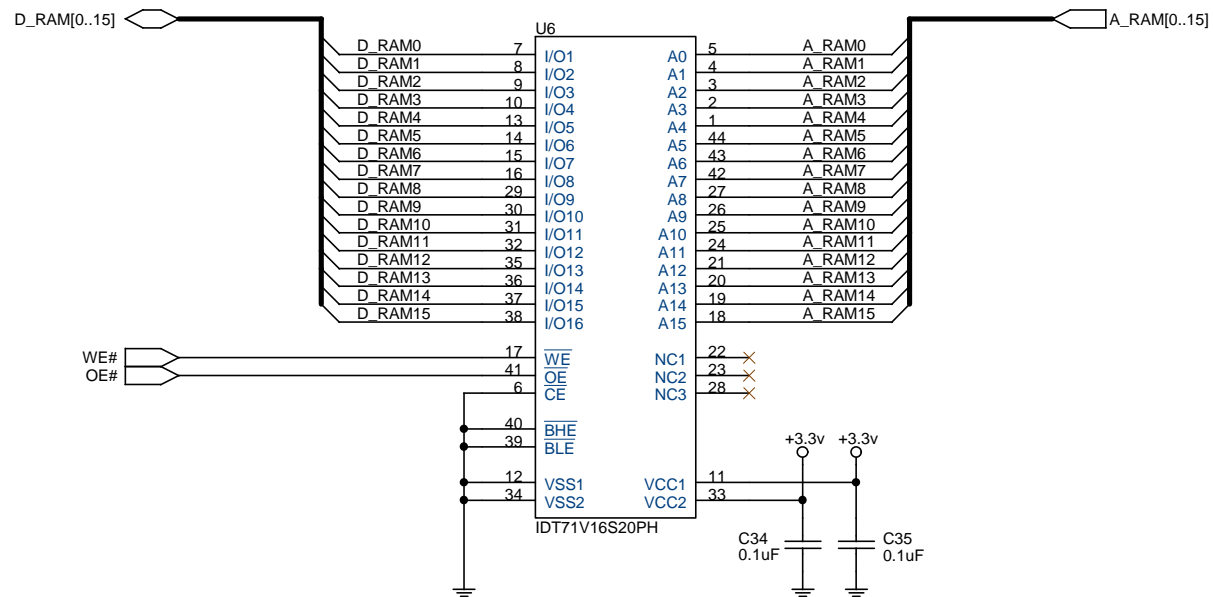

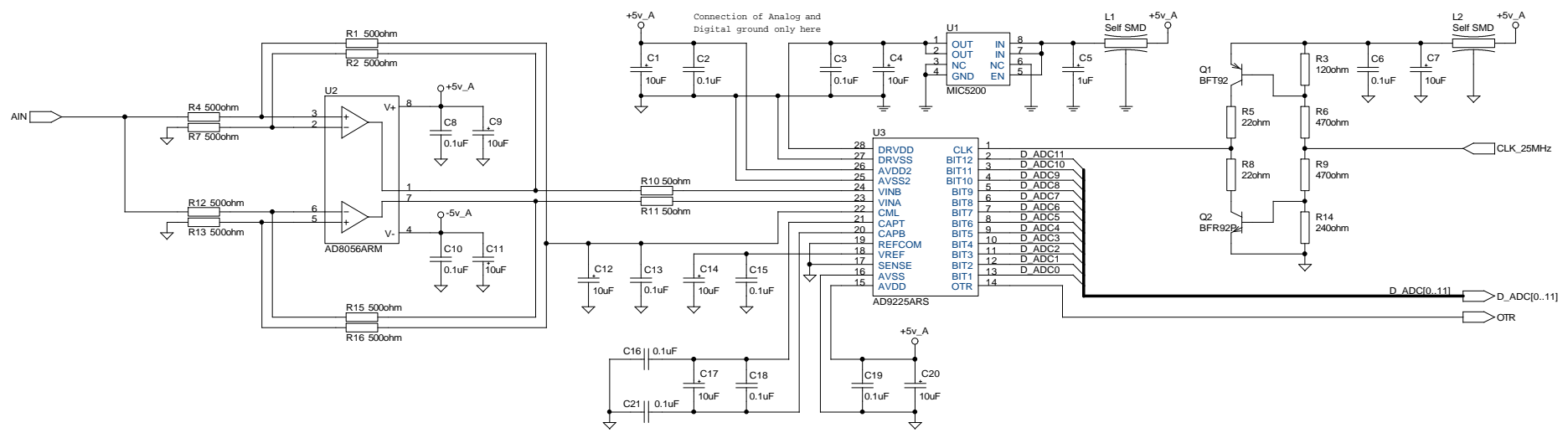

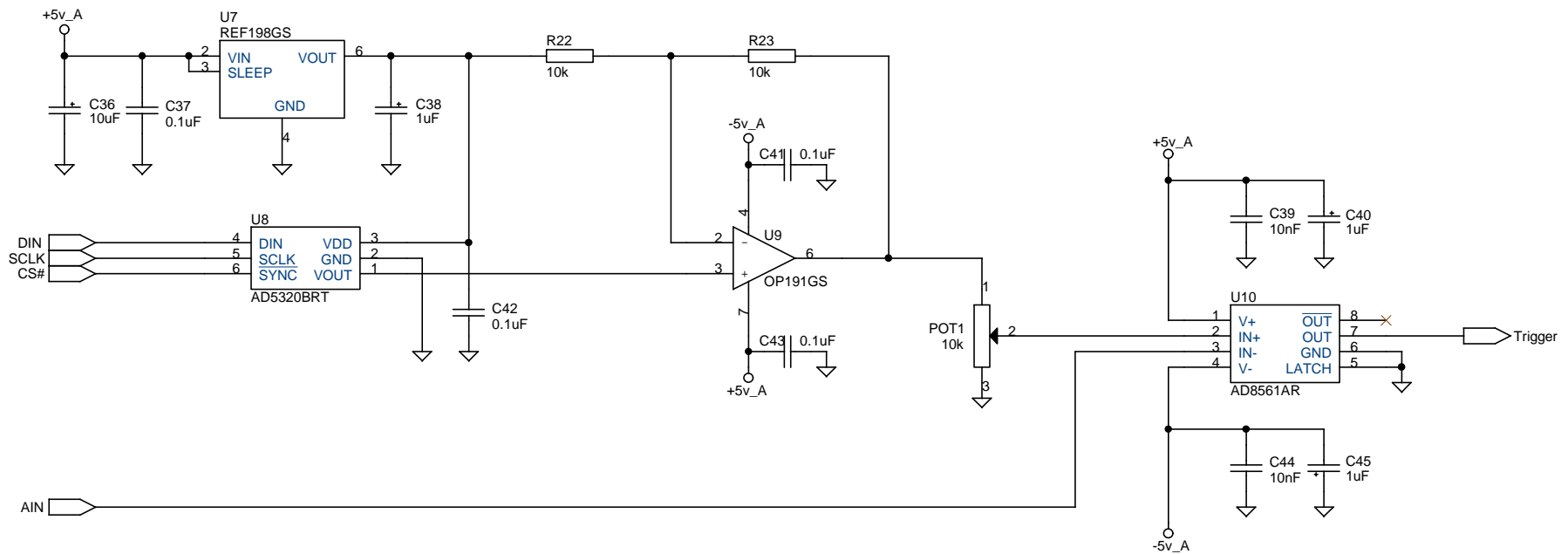

Mario Pasquali - Ecole d'Ingénieurs de Genève		
Title Scope - Acquisition Board - Trigger		
Size A4	Document Number 1.0	Rev 0
Date: Monday, November 27, 2000	Sheet 8	of 8

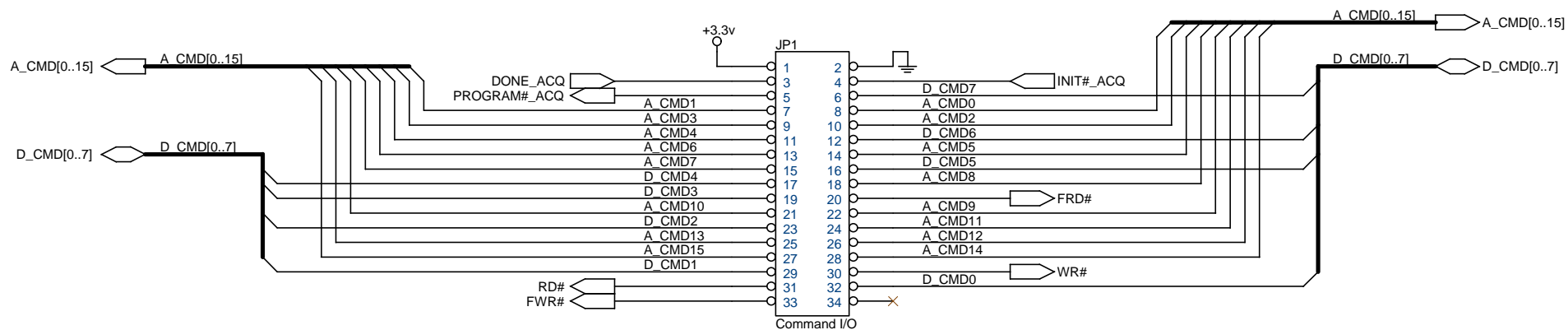

Mario Pasquali - Ecole d'Ingénieurs de Genève		
Title Scope - Acquisition Board - Command I/O		
Size A4	Document Number 1.0	Rev 0
Date: Sunday, September 19, 1999	Sheet 3	of 8

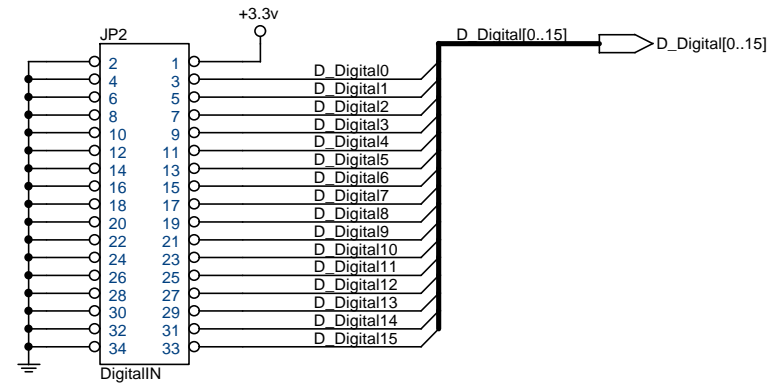

<i>Mario Pasquali - Ecole d'Ingénieurs de Genève</i>		
Title Scope - Acquisition Board - Input		
Size A4	Document Number 1.0	Rev 0
Date:	Wednesday, September 15, 1999	Sheet 5 of 8

Tous les condensateurs 10uF sont Low-ESR !

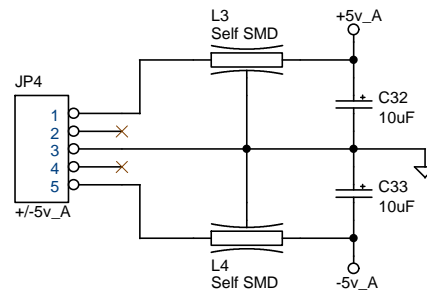
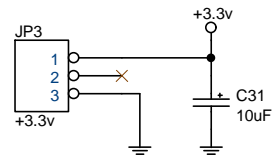

<i>Mario Pasquali - Ecole d'Ingénieurs de Genève</i>		
Title		
Scope - Acquisition Board - Power Supply		
Size	Document Number	Rev
A4	1.0	0
Date:	Wednesday, September 15, 1999	Sheet 6 of 8

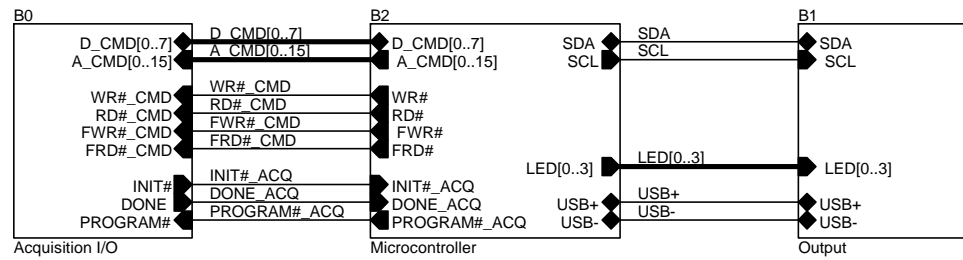

<i>Mario Pasquali - Ecole d'Ingénieurs de Genève</i>		
Title		
Scope - Command Board - Main		
Size	Document Number	Rev
A4	1.0	0
Date:	Monday, November 27, 2000	Sheet 1 of 5

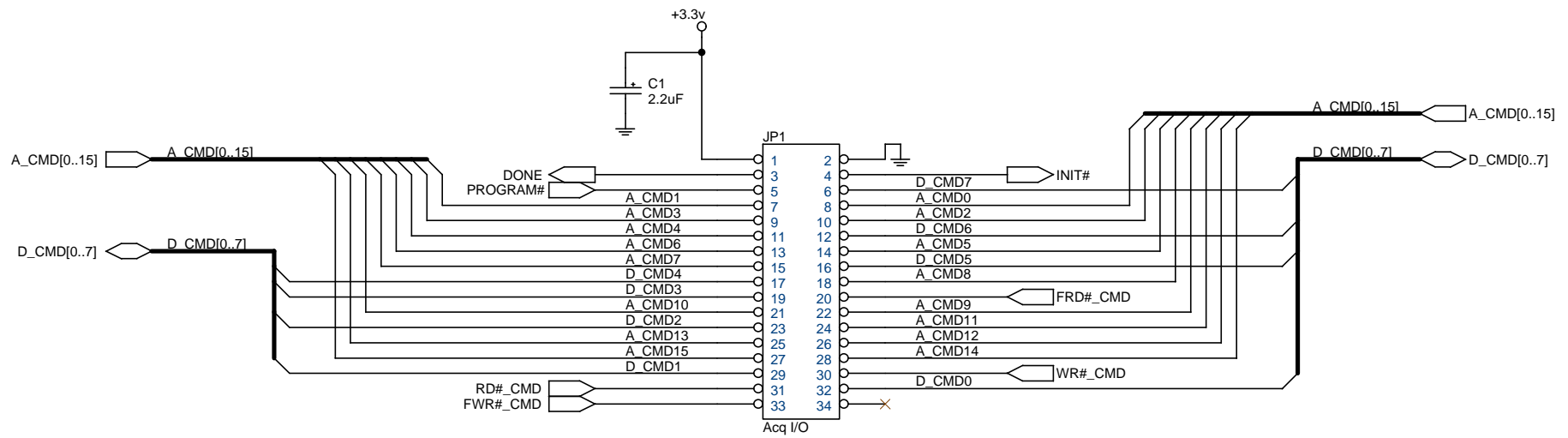

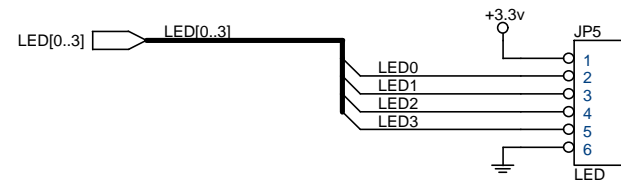
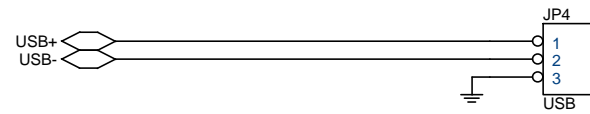
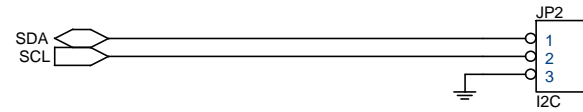

<i>Mario Pasquali - Ecole d'Ingénieurs de Genève</i>		
Title		
Scope - Command Board - Output		
Size	Document Number	Rev
A4	1.0	0
Date:	Monday, November 27, 2000	Sheet 5 of 5