

# 82580 REFERENCE DESIGN

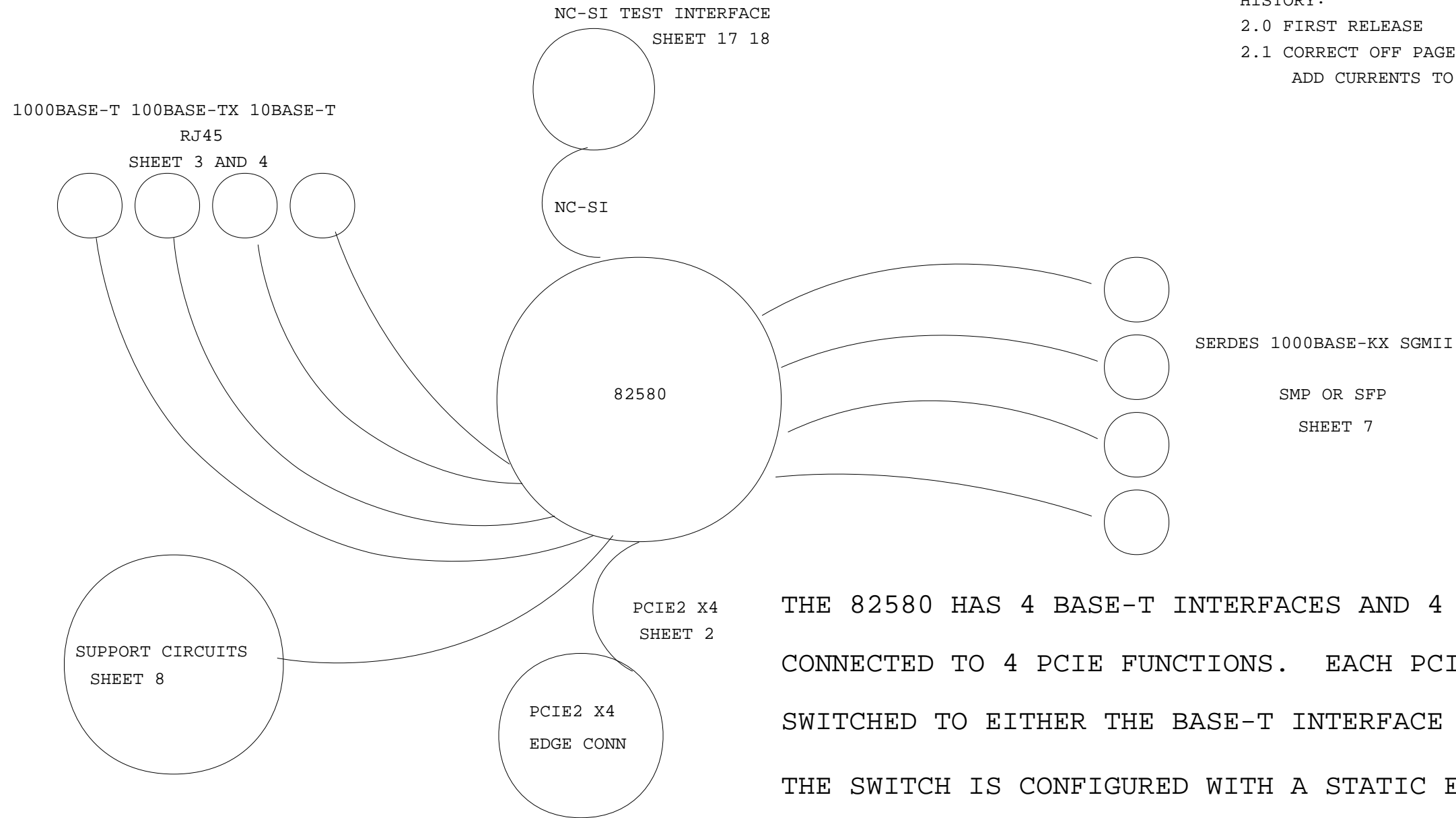

HISTORY:  
 2.0 FIRST RELEASE  
 2.1 CORRECT OFF PAGE REFERENCES  
 ADD CURRENTS TO POWER FILTER PAGE

THE 82580 HAS 4 BASE-T INTERFACES AND 4 SERDES INTERFACES CONNECTED TO 4 PCIE FUNCTIONS. EACH PCIE FUNCTION CAN BE SWITCHED TO EITHER THE BASE-T INTERFACE OR THE SERDES INTERFACE. THE SWITCH IS CONFIGURED WITH A STATIC EEPROM SETTING OR DYNAMICALLY THROUGH A REGISTER SETTING.

INTEL CONFIDENTIAL

UNKNOWN

LAN ACCESS DIVISION  
 2111 N.E. 25th AVENUE  
 HILLSBORO, OR 97124

TITLE 82580 REFERENCE DESIGN

SIZE  
B

CODE

DOCUMENT NUMBER

322445-007EN

REV  
2.2

DATE  
2010-06-25

SHEET  
1

# PCIE NC-SI SMB JTAG

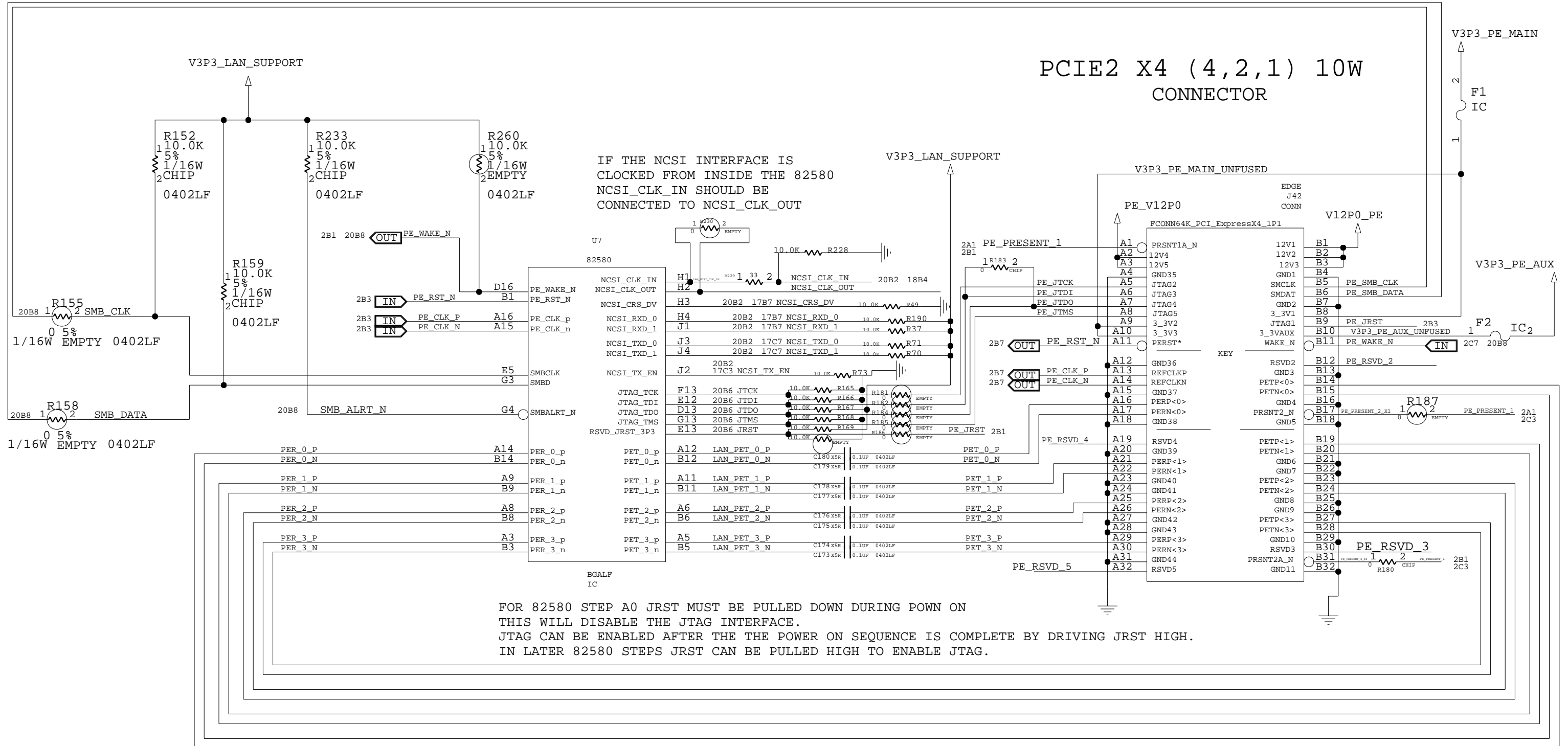

INTEL CONFIDENTIAL

UNKNOWN

LAN ACCESS DIVISION  
2111 N.E. 25th AVENUE  
HILLSBORO, OR 97124

TITLE 82580 REFERENCE DESIGN

SIZE B CODE DOCUMENT NUMBER

322445-007EN

REV 2.2

DATE 2010-06-25

SHEET 2

THE MDI INTERFACE ON THE 82580 IS INTERNALLY TERMINATED.  
EXTERNAL MDI TERMINATION IS NOT REQUIRED

THE SYSTEM SIDE CENTER TAP IS NOT  
CONNECTED TO A VOLTAGE ON THE 82580.  
THE MDI INTERFACE IS INTERNALLY BIASED

# MDI 10BASE-T/100BASE-TX/1000BASE-T

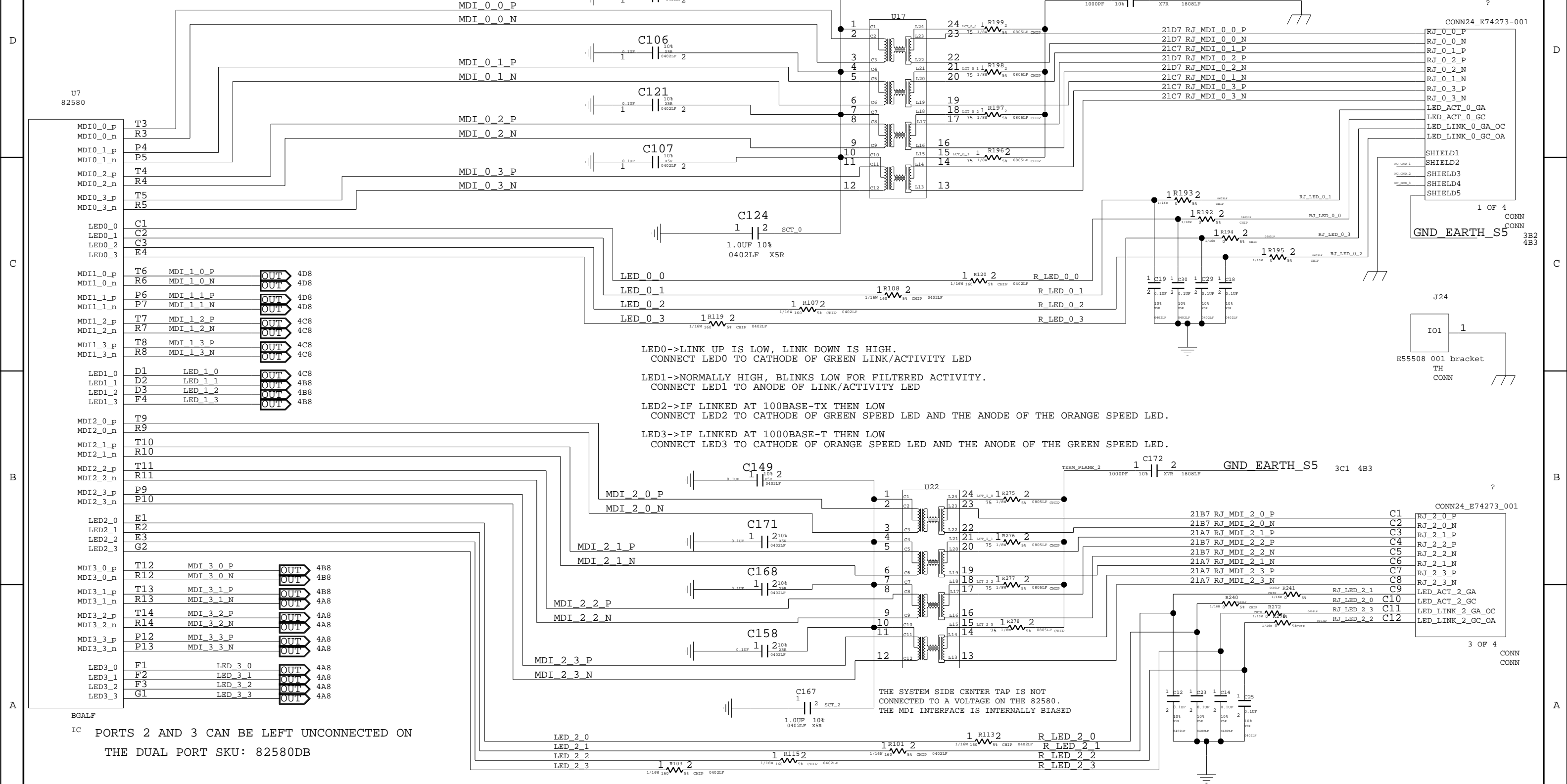

LED0->LINK UP IS LOW, LINK DOWN IS HIGH.  
CONNECT LED0 TO CATHODE OF GREEN LINK/ACTIVITY LED

LED1->NORMALLY HIGH, BLINKS LOW FOR FILTERED ACTIVITY.  
CONNECT LED1 TO ANODE OF LINK/ACTIVITY LED

LED2->IF LINKED AT 100BASE-TX THEN LOW  
CONNECT LED2 TO CATHODE OF GREEN SPEED LED AND THE ANODE OF THE ORANGE SPEED LED.

LED3->IF LINKED AT 1000BASE-T THEN LOW  
CONNECT LED3 TO CATHODE OF ORANGE SPEED LED AND THE ANODE OF THE GREEN SPEED LED.

IC PORTS 2 AND 3 CAN BE LEFT UNCONNECTED ON  
THE DUAL PORT SKU: 82580DB

INTEL CONFIDENTIAL

UNKNOWN

LAN ACCESS DIVISION  
2111 N.E. 25th AVENUE  
HILLSBORO, OR 97124

TITLE 82580 REFERENCE DESIGN

SIZE B CODE DOCUMENT NUMBER 322445-007EN

REV 2.2

DATE 2010-06-25

SHEET 3

MDI 10BASE-T/100BASE-TX/1000BASE-T

THE MDI INTERFACE ON THE 82580 IS INTERNALLY TERMINATED.  
EXTERNAL MDI TERMINATION IS NOT REQUIRED

THE SYSTEM SIDE CENTER TAP IS NOT  
CONNECTED TO A VOLTAGE ON THE 82580.  
THE MDI INTERFACE IS INTERNALLY BIASED

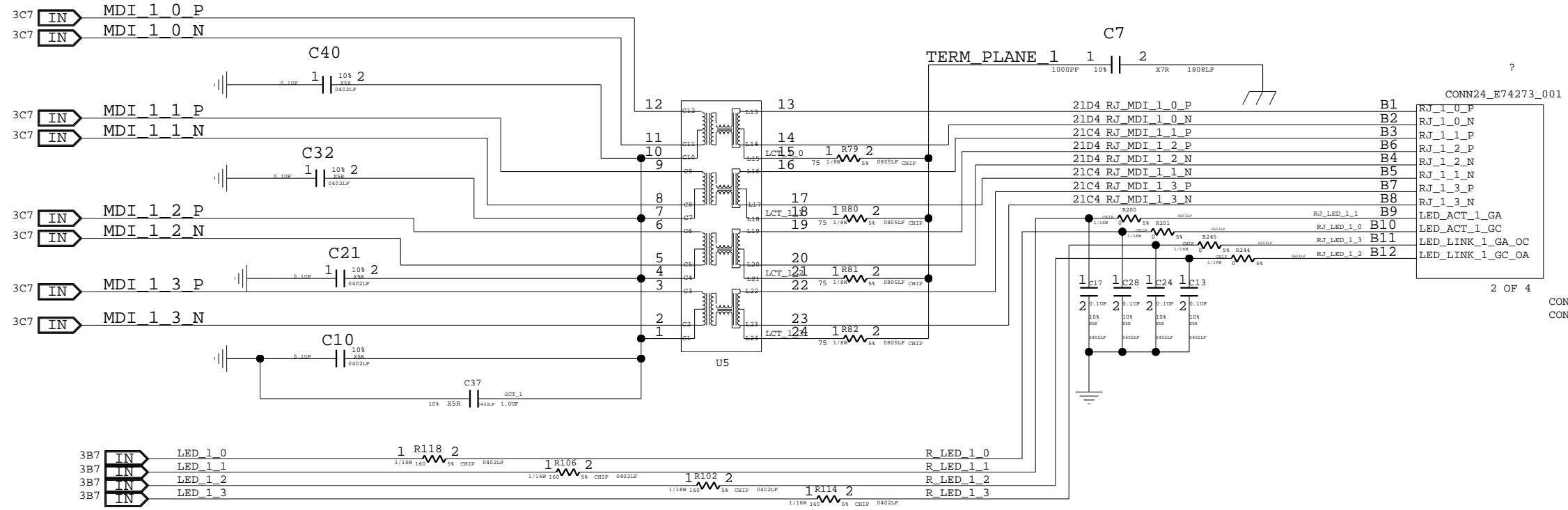

LED0->LINK UP IS LOW, LINK DOWN IS HIGH.  
CONNECT LED0 TO CATHODE OF GREEN LINK/ACTIVITY LED

LED1->NORMALLY HIGH, BLINKS LOW FOR FILTERED ACTIVITY.  
CONNECT LED1 TO ANODE OF LINK/ACTIVITY LED

LED2->IF LINKED AT 100BASE-TX THEN LOW  
CONNECT LED2 TO CATHODE OF GREEN SPEED LED AND THE ANODE OF THE ORANGE SPEED LED.

LED3->IF LINKED AT 1000BASE-T THEN LOW  
CONNECT LED3 TO CATHODE OF ORANGE SPEED LED AND THE ANODE OF THE GREEN SPEED LED.

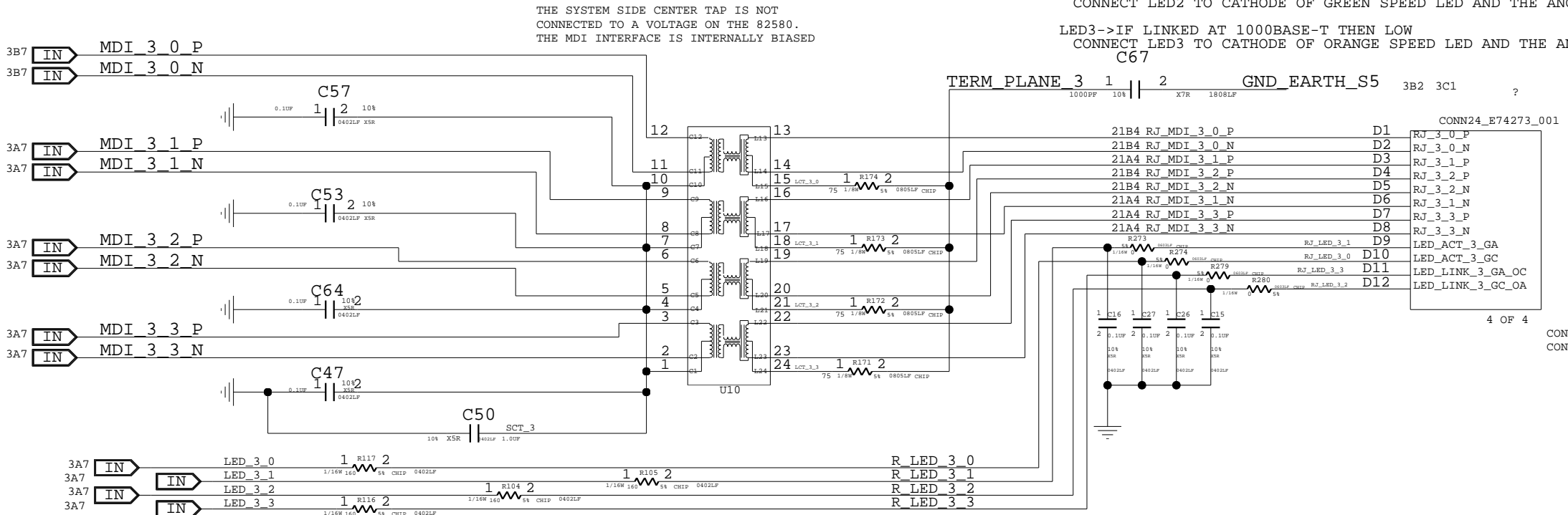

HEATSINK

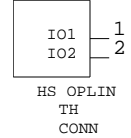

INTEL CONFIDENTIAL

UNKNOWN

LAN ACCESS DIVISION 2111 N.E. 25th AVENUE HILLSBORO, OR 97124	TITLE <b>82580 REFERENCE DESIGN</b>	SIZE B	CODE	DOCUMENT NUMBER <b>322445-007EN</b>	REV 2.2	DATE 2010-06-25	SHEET 4
---	--	-----------	------	--	------------	--------------------	------------

### SFP\_0 POWER CONTROL

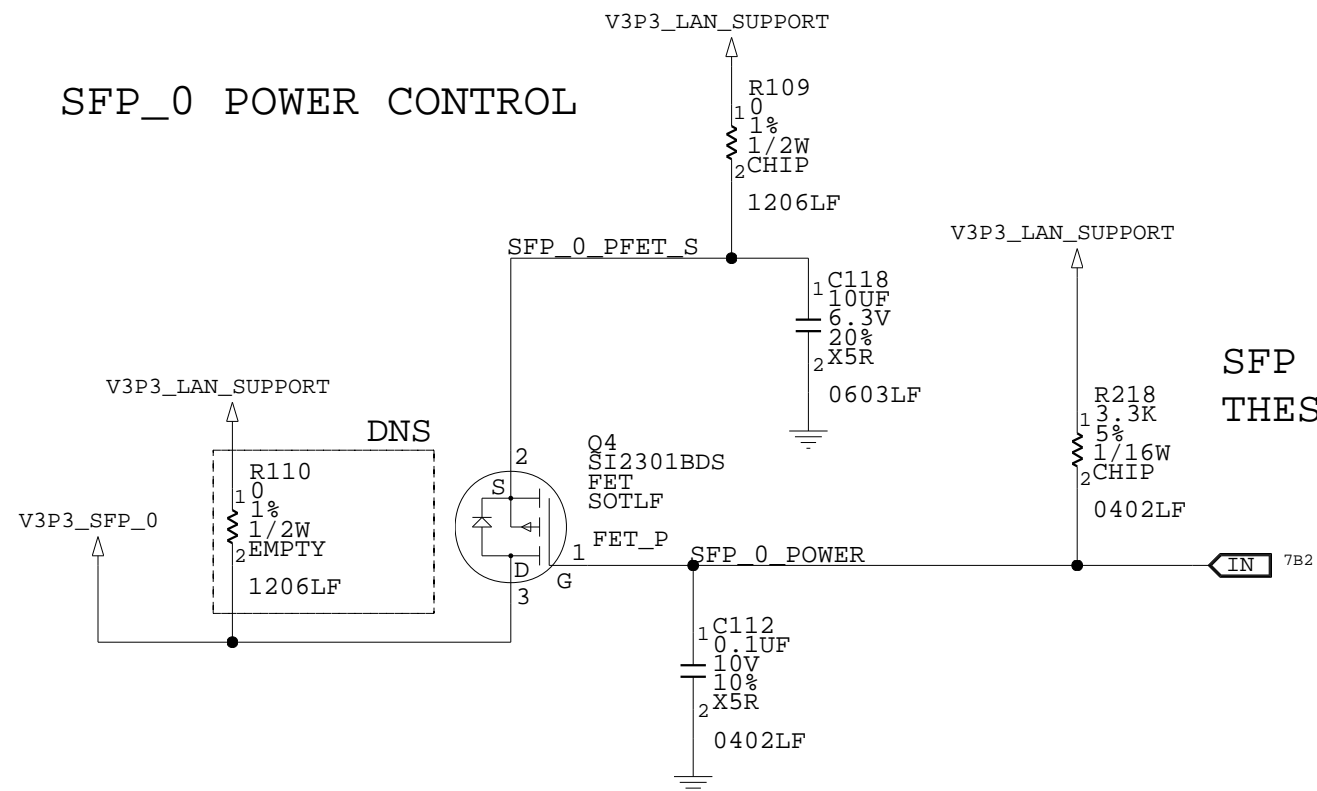

SFP MODULES MAY NEED TO BE SHUT DOWN WHILE IN LOW POWER STATES  
 THESE FETS ALLOW SOFTWARE TO CONTROL THE SFP MODULE POWER.

### SFP\_1 POWER CONTROL

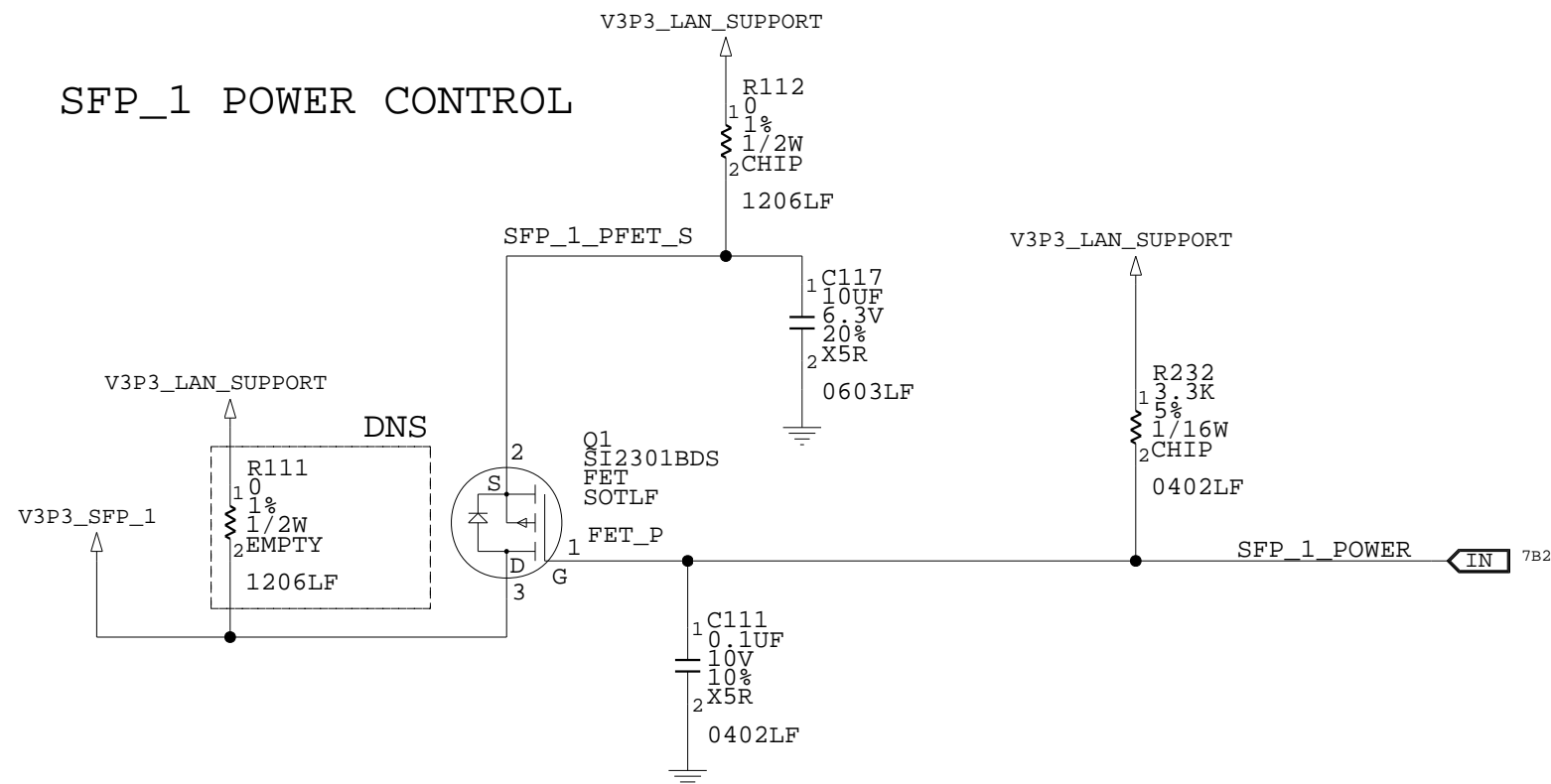

INTEL CONFIDENTIAL

UNKNOWN

LAN ACCESS DIVISION  
 2111 N.E. 25th AVENUE  
 HILLSBORO, OR 97124

TITLE 82580 REFERENCE DESIGN

SIZE  
 B

CODE

DOCUMENT NUMBER

322445-007EN

REV  
 2.2

DATE  
 2010-06-25

SHEET  
 5

### SFP\_2 POWER CONTROL

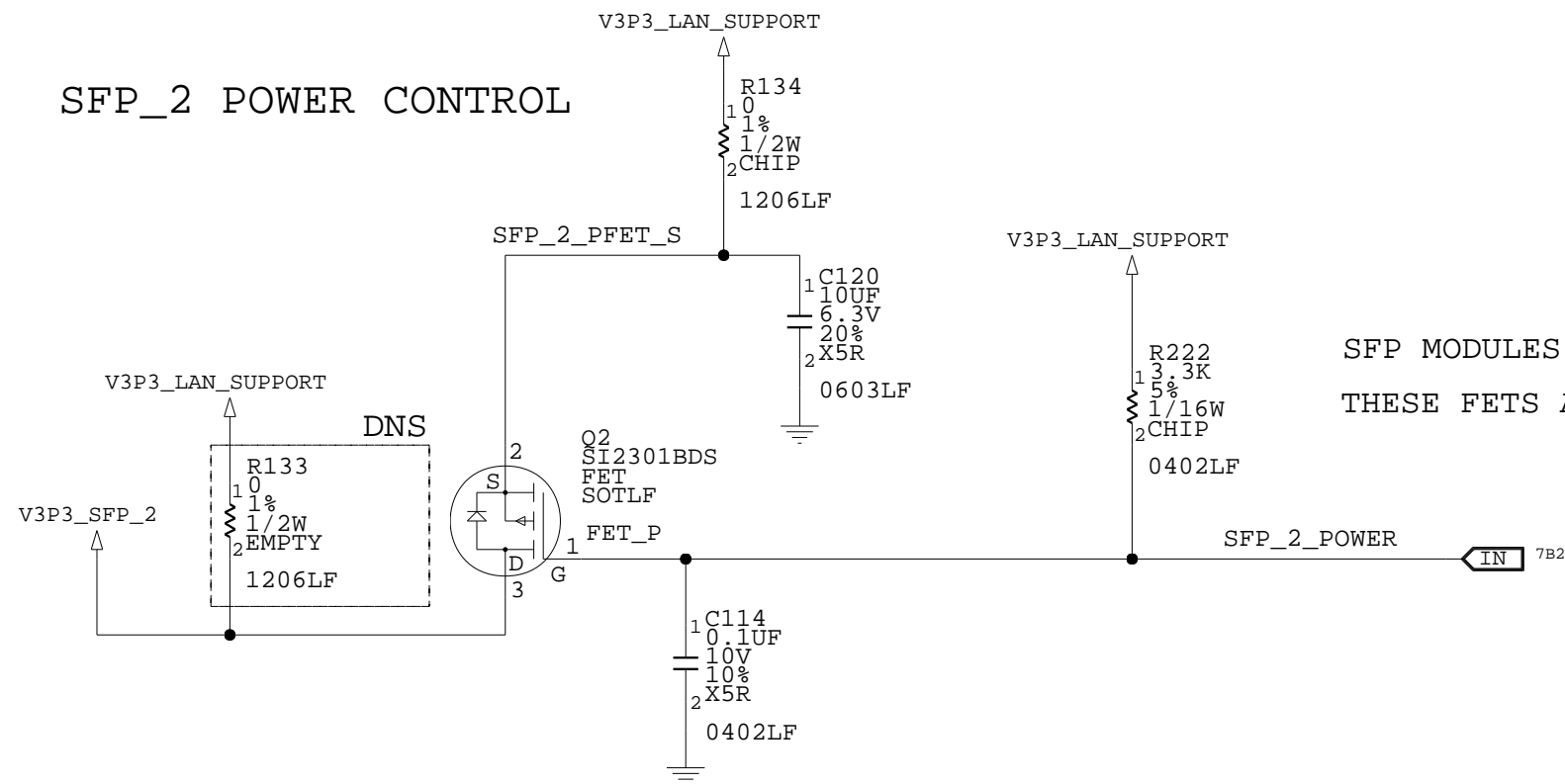

SFP MODULES MAY NEED TO BE SHUT DOWN WHILE IN LOW POWER STATES  
 THESE FETS ALLOW SOFTWARE TO CONTROL THE SFP MODULE POWER.

### SFP\_3 POWER CONTROL

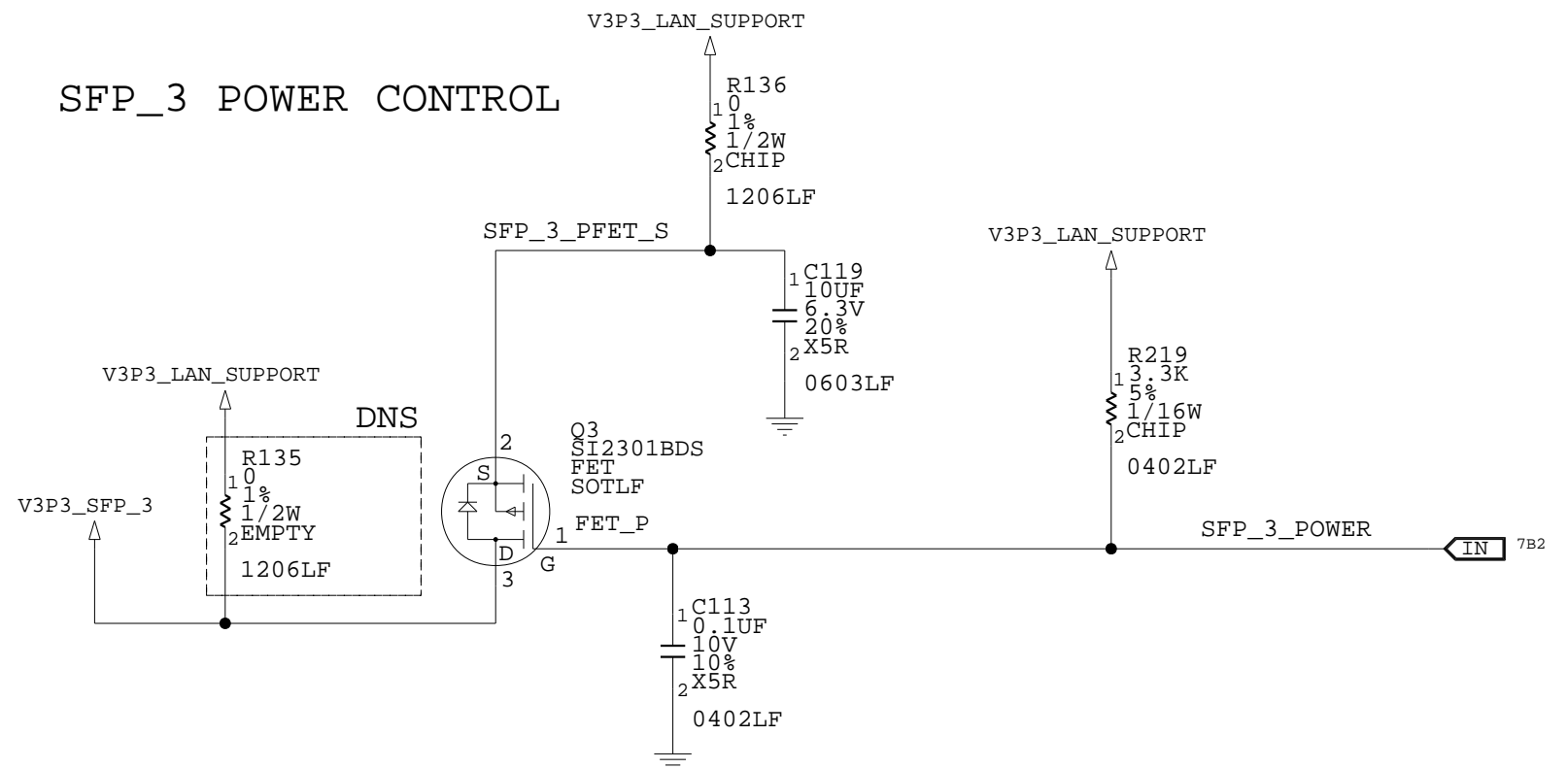

INTEL CONFIDENTIAL

UNKNOWN

LAN ACCESS DIVISION  
 2111 N.E. 25th AVENUE  
 HILLSBORO, OR 97124

TITLE 82580 REFERENCE DESIGN

SIZE  
B

CODE

DOCUMENT NUMBER

322445-007EN

REV  
2.2

DATE  
2010-06-25

SHEET  
6

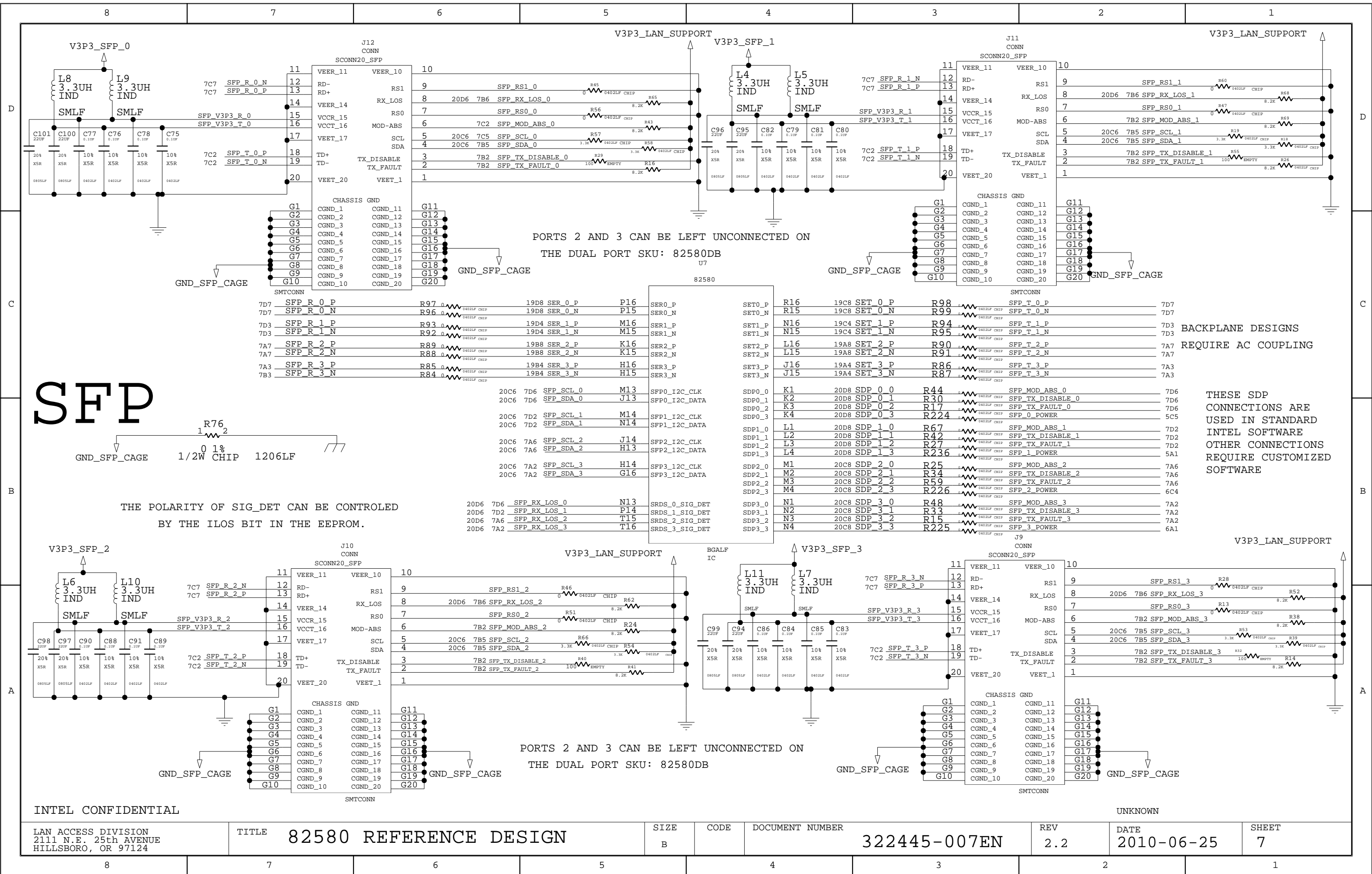

# SFP

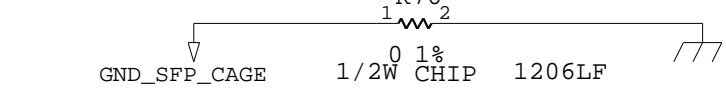

THE POLARITY OF SIG\_DET CAN BE CONTROLLED BY THE ILOS BIT IN THE EEPROM.

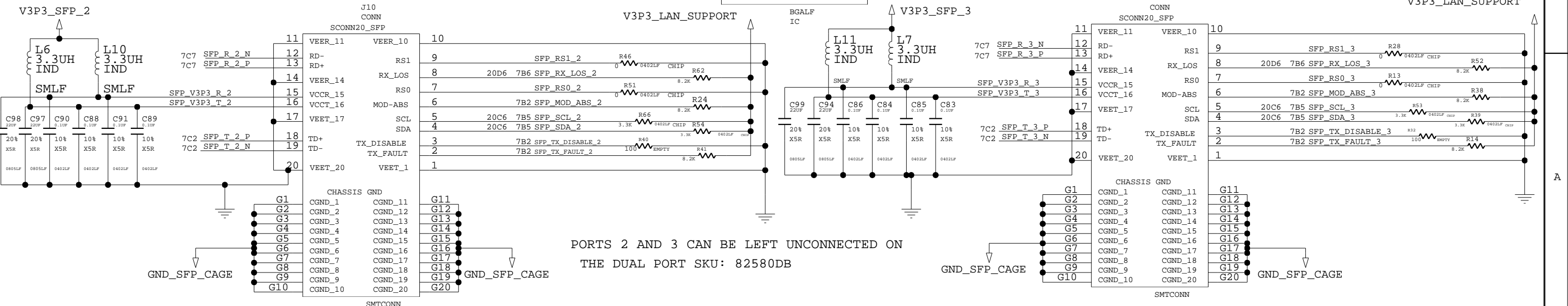

INTEL CONFIDENTIAL

UNKNOWN

LAN ACCESS DIVISION 2111 N.E. 25th AVENUE HILLSBORO, OR 97124	TITLE <b>82580 REFERENCE DESIGN</b>	SIZE B	CODE	DOCUMENT NUMBER <b>322445-007EN</b>	REV 2.2	DATE 2010-06-25	SHEET 7
---	--	-----------	------	--	------------	--------------------	------------

BACKPLANE DESIGNS REQUIRE AC COUPLING

THESE SDP CONNECTIONS ARE USED IN STANDARD INTEL SOFTWARE OTHER CONNECTIONS REQUIRE CUSTOMIZED SOFTWARE

# SUPPORT CIRCUITS

THE CAPACITORS BETWEEN THE CRYSTAL AND GROUND MAY NEED TO BE ADJUSTED BASED ON PARASITIC CAPACITANCE OF TRACES ON THE BOARD. 33 PF MAY BE A BETTER CHOICE FOR A SMALL CRYSTAL WITH VERY SHORT TRACES.

A FLASH DEVICE IS NOT REQUIRED IF PXE AND/OR ISCSI BOOT CODE IS INTEGRATED INTO THE BIOS

D

C

B

A

D

C

B

A

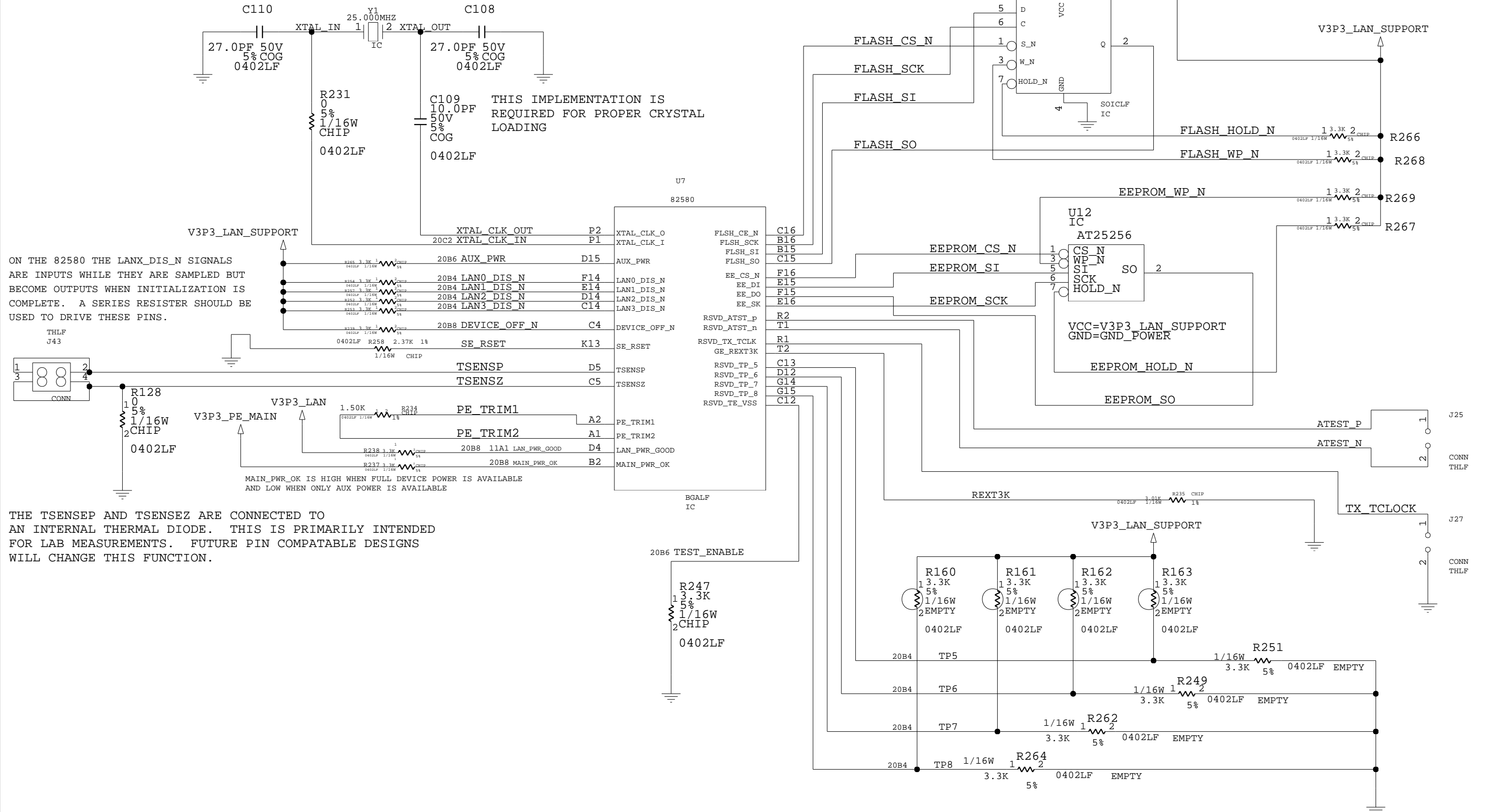

INTEL CONFIDENTIAL

UNKNOWN

LAN ACCESS DIVISION  
2111 N.E. 25th AVENUE  
HILLSBORO, OR 97124

TITLE 82580 REFERENCE DESIGN

SIZE B

CODE

DOCUMENT NUMBER

322445-007EN

REV 2.2

DATE 2010-06-25

SHEET 8

# POWER SUPPLIES

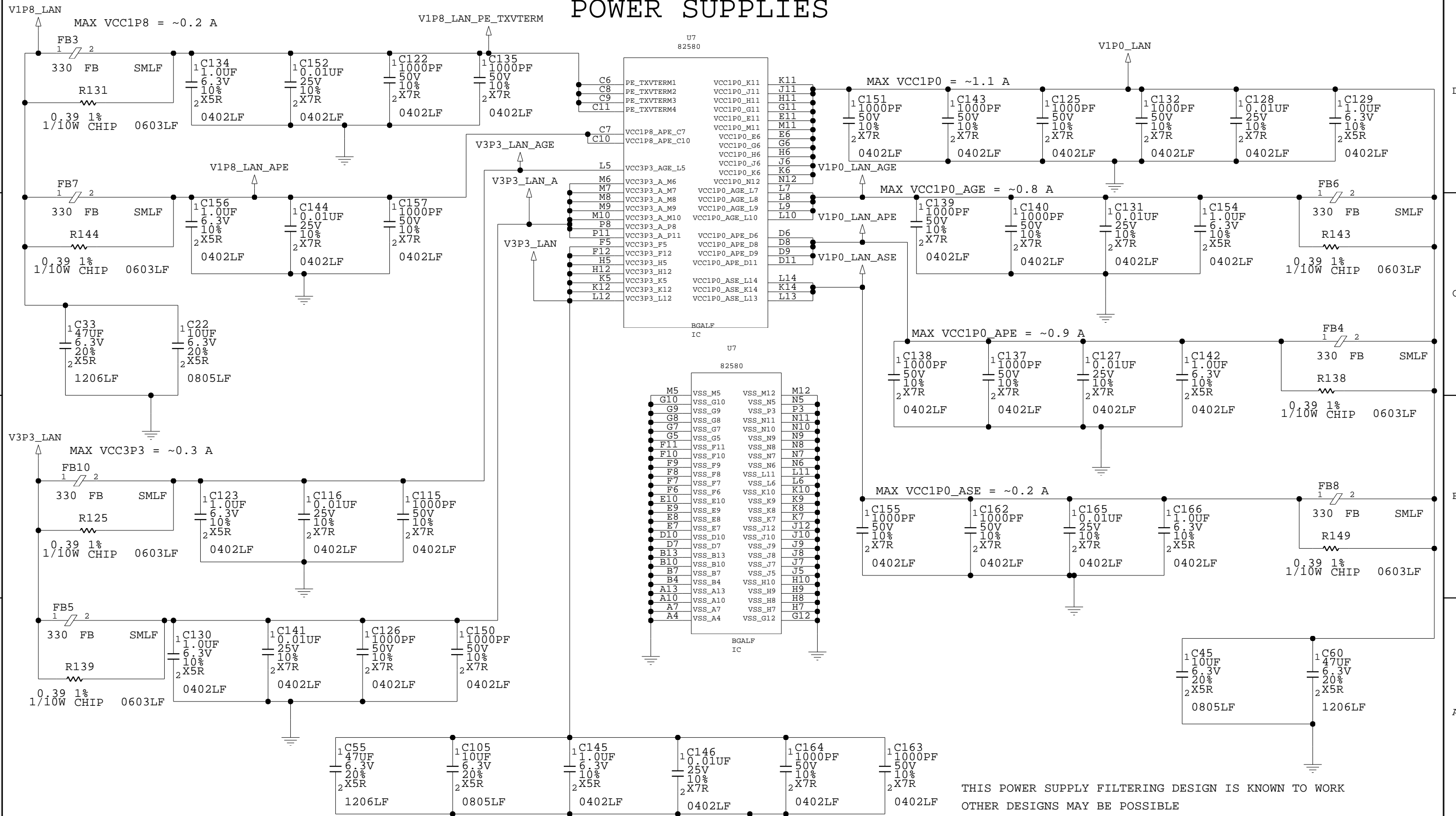

INTEL CONFIDENTIAL

LAN ACCESS DIVISION  
2111 N.E. 25th AVENUE  
HILLSBORO, OR 97124

TITLE 82580 REFERENCE DESIGN

SIZE  
B

CODE

DOCUMENT NUMBER

322445-007EN

REV  
2.2

DATE  
2010-06-25

SHEET  
9



DETECT AND VAUX DISABLE CIRCUIT WITH DIODE "OR" OUTPUT

3.3V ENABLE CIRCUIT

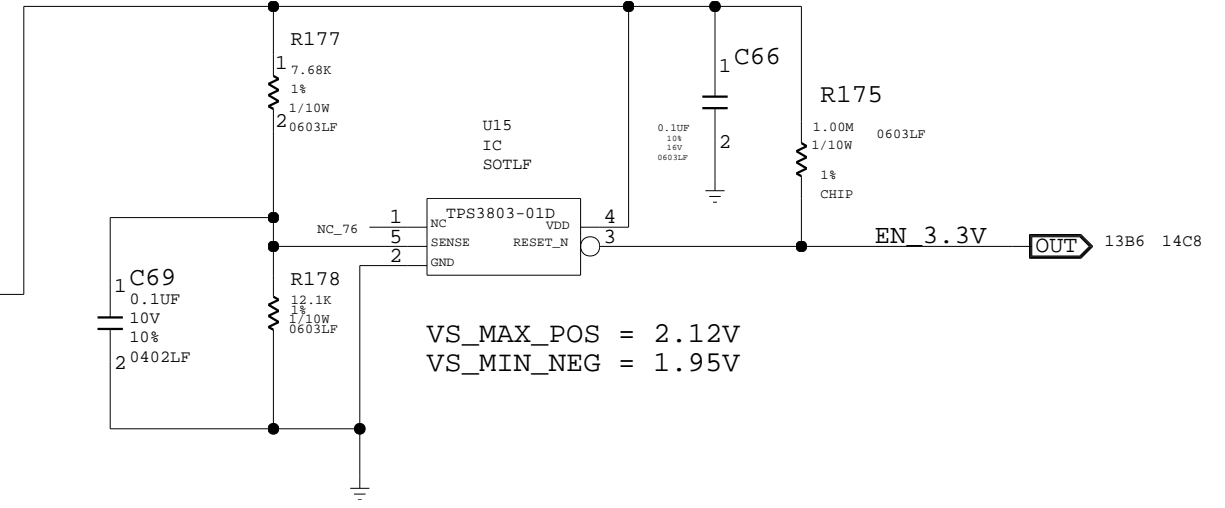
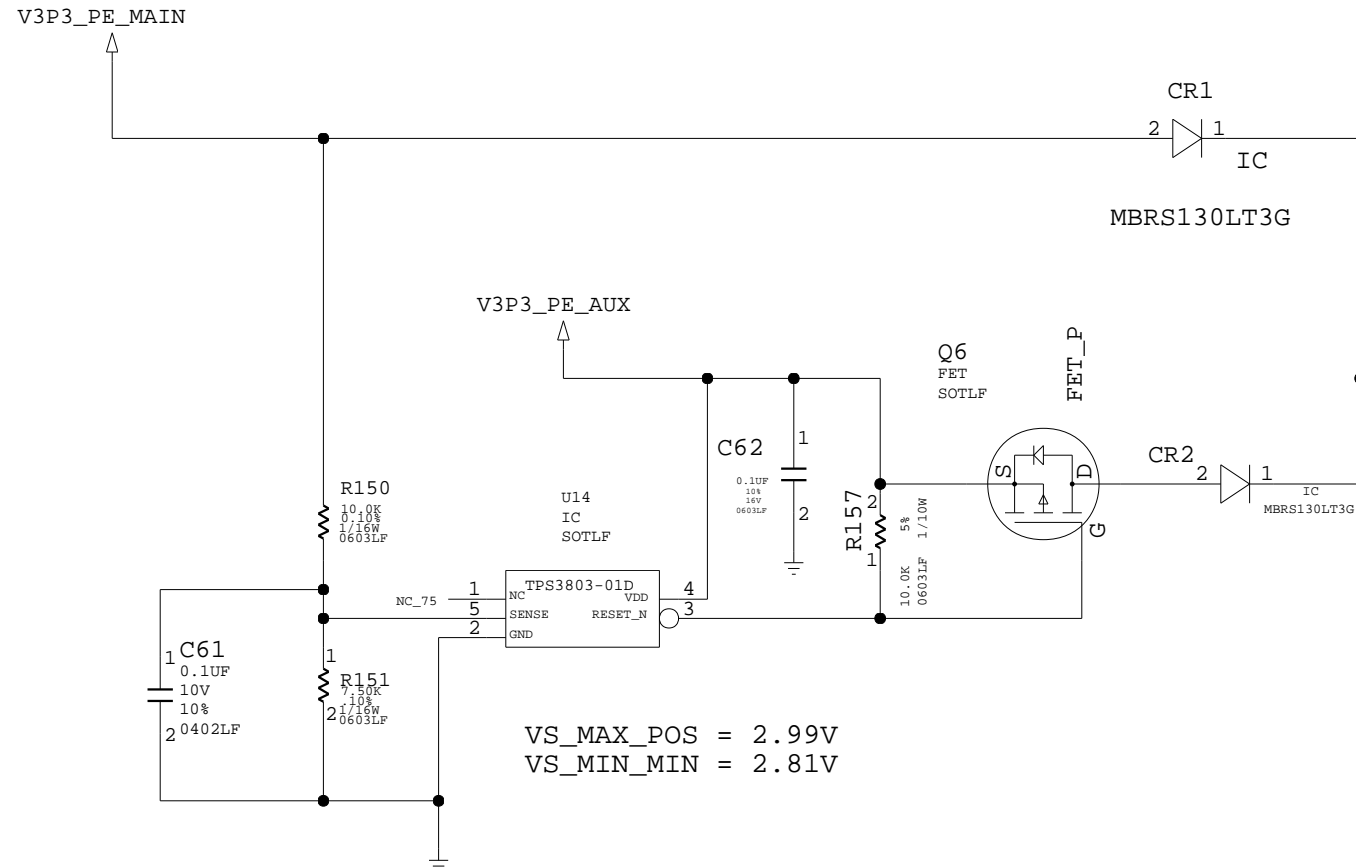

82580 LAN\_PWR\_GOOD GENERATOR

EXTERNAL LAN\_PWR\_GOOD GENERATION IS NOT REQUIRED IN MOST DESIGNS  
 82580 INTERNAL POWER GOOD INDICATION IS A LOGICAL AND OF THE EXTERNAL LAN\_PWR\_GOOD PIN AND AN INTERNAL POWER ON RESET CIRCUIT.

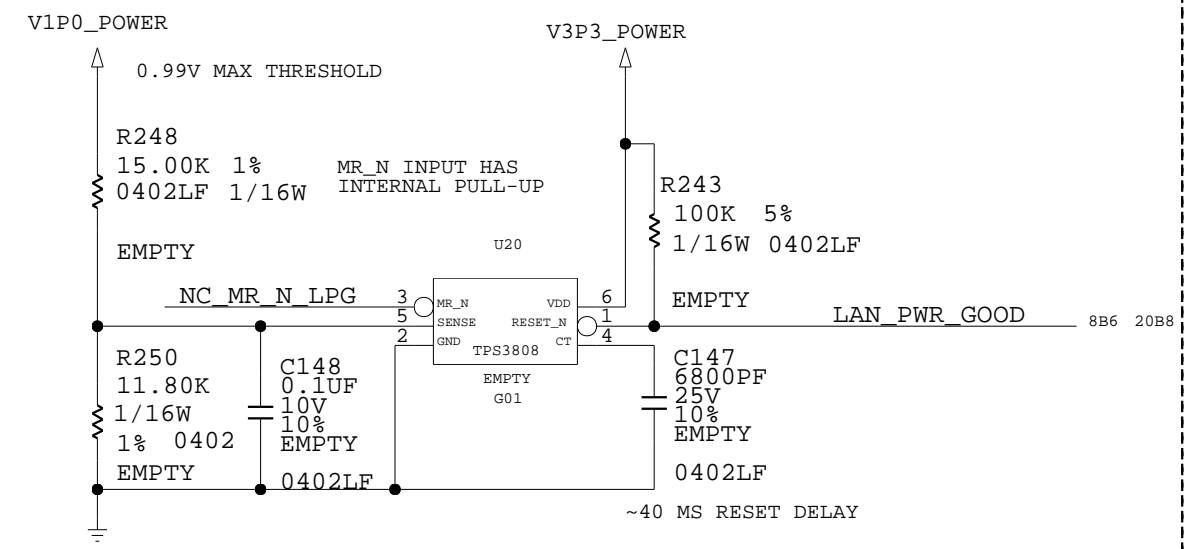

DNS

11 - DETECT, DIODE "OR" AND 3.3V ENABLE CIRCUIT  
 INTEL

LAN ACCESS DIVISION 2111 N.E. 25th AVENUE HILLSBORO, OR 97124	TITLE <b>82580 REFERENCE DESIGN</b>	SIZE B	CODE	DOCUMENT NUMBER <b>322445-007EN</b>	REV 2.2	DATE 2010-06-25	SHEET 11
---	--	-----------	------	--	------------	--------------------	-------------

### 1.8V ENABLE CIRCUIT

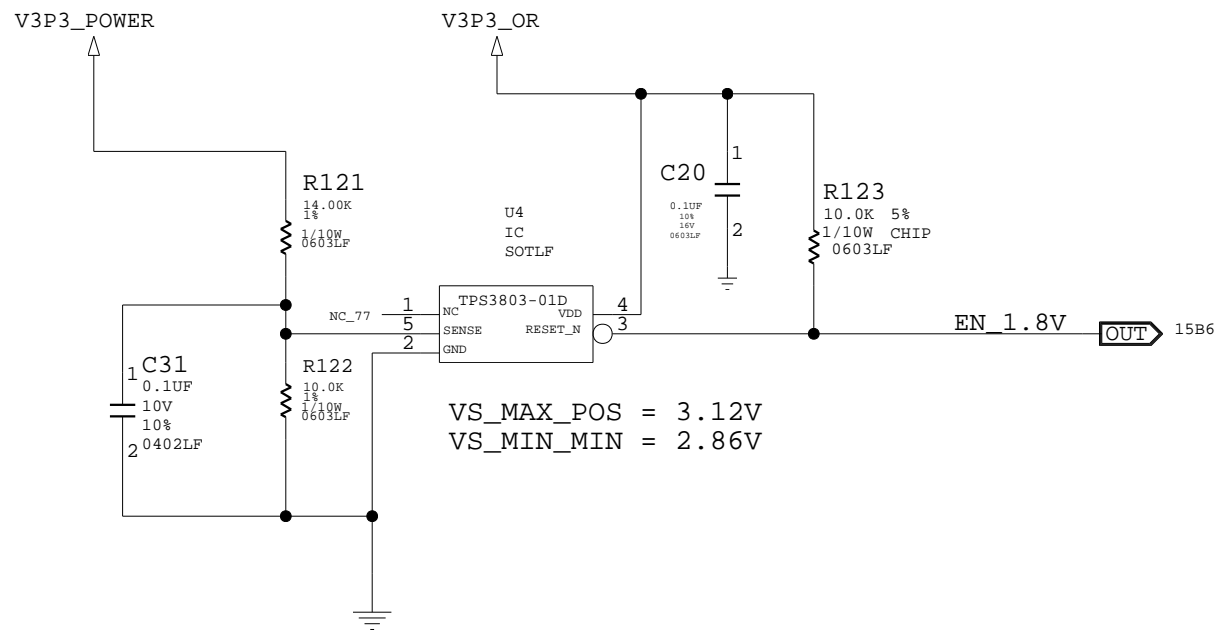

### 1.0V ENABLE CIRCUIT

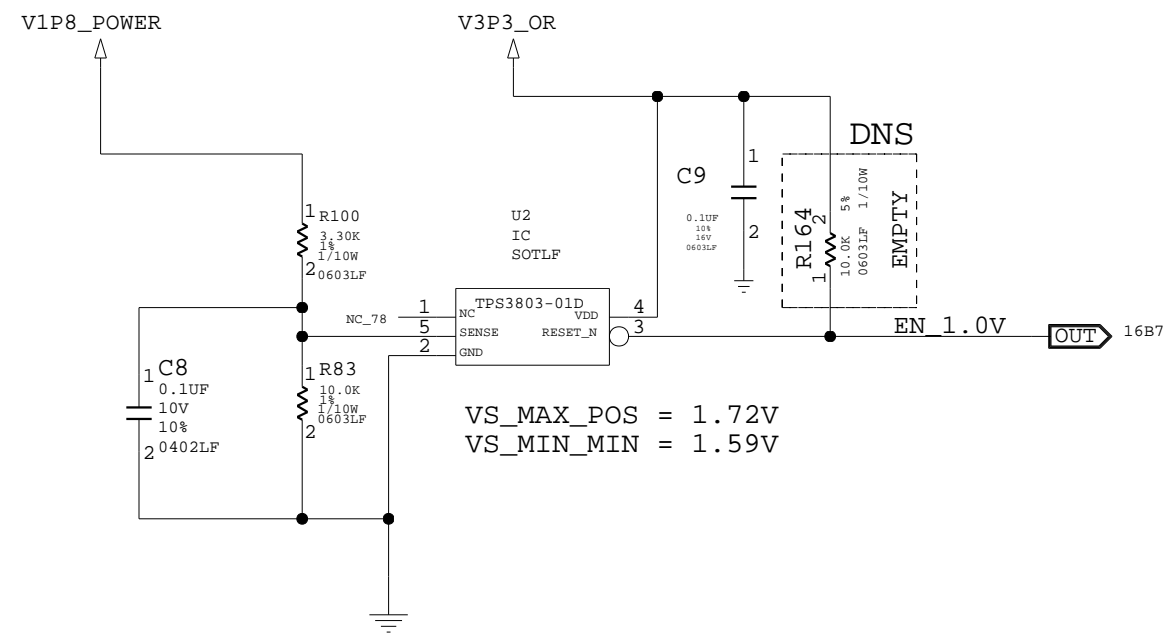

13 - 1.8V AND 1.0V ENABLE CIRCUITS  
INTEL

LAN ACCESS DIVISION  
2111 N.E. 25th AVENUE  
HILLSBORO, OR 97124

TITLE 82580 REFERENCE DESIGN

SIZE  
B

CODE

DOCUMENT NUMBER

322445-007EN

REV  
2.2

DATE  
2010-06-25

SHEET  
12

# TPS63000 BUCK/BOOST REGULATOR FOR 3.3V

VOLTAGE BOOST REQUIRED TO COMPENSATE FOR  
 VOLTAGE DROP FROM DIODE OR CIRCUIT. MANY DESIGNS  
 MAY NOT REQUIRE A BOOST CIRCUIT.

VOUT\_MAX = 3.47V  
 VOUT\_MIN = 3.28V

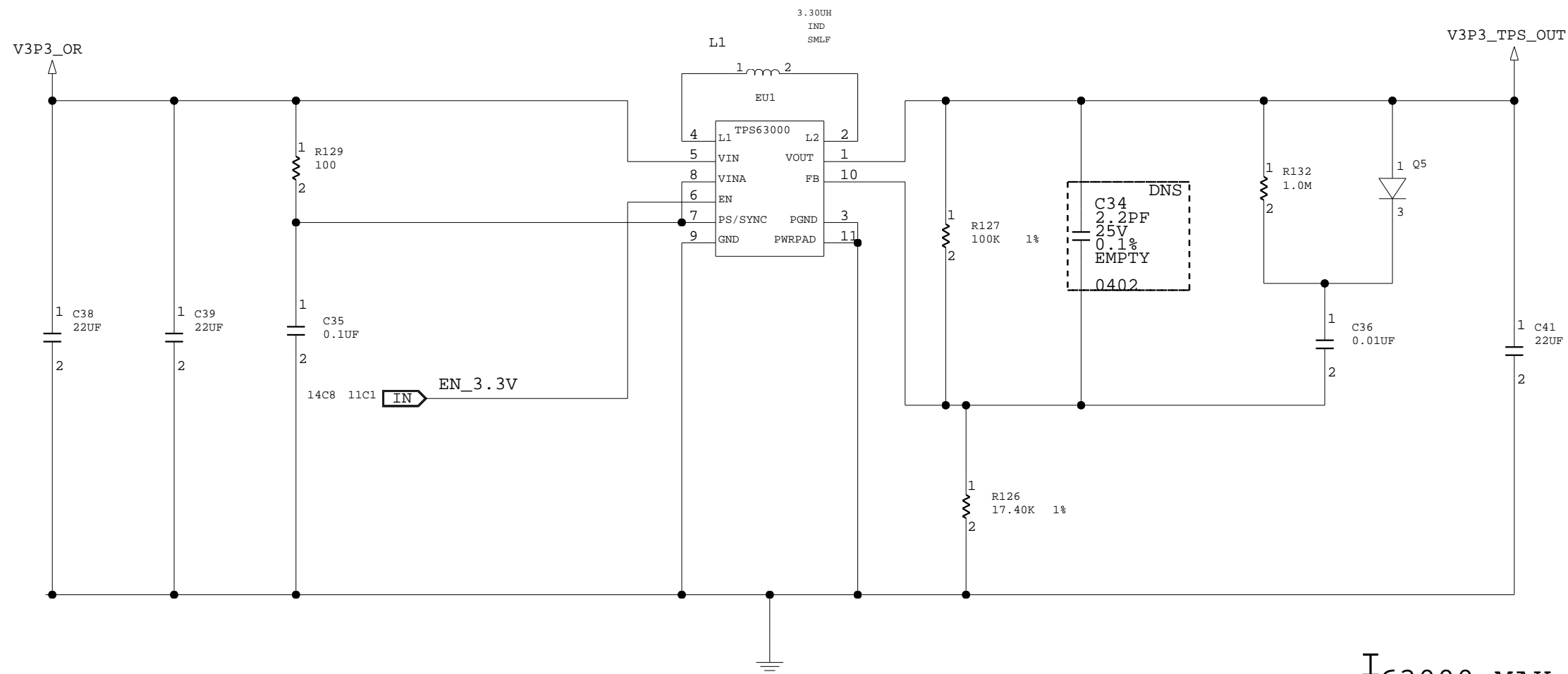

$I_{63000-MAX} = 0.800A$

13 - 3.3V REGULATOR  
 INTEL

LAN ACCESS DIVISION  
 2111 N.E. 25th AVENUE  
 HILLSBORO, OR 97124

TITLE 82580 REFERENCE DESIGN

SIZE  
 B

CODE

DOCUMENT NUMBER

322445-007EN

REV  
 2.2

DATE  
 2010-06-25

SHEET  
 13

# LTC3533 BUCK/BOOST REGULATOR FOR 3.3V (REQUIRED FOR 4-PORT SFP OPERATION)

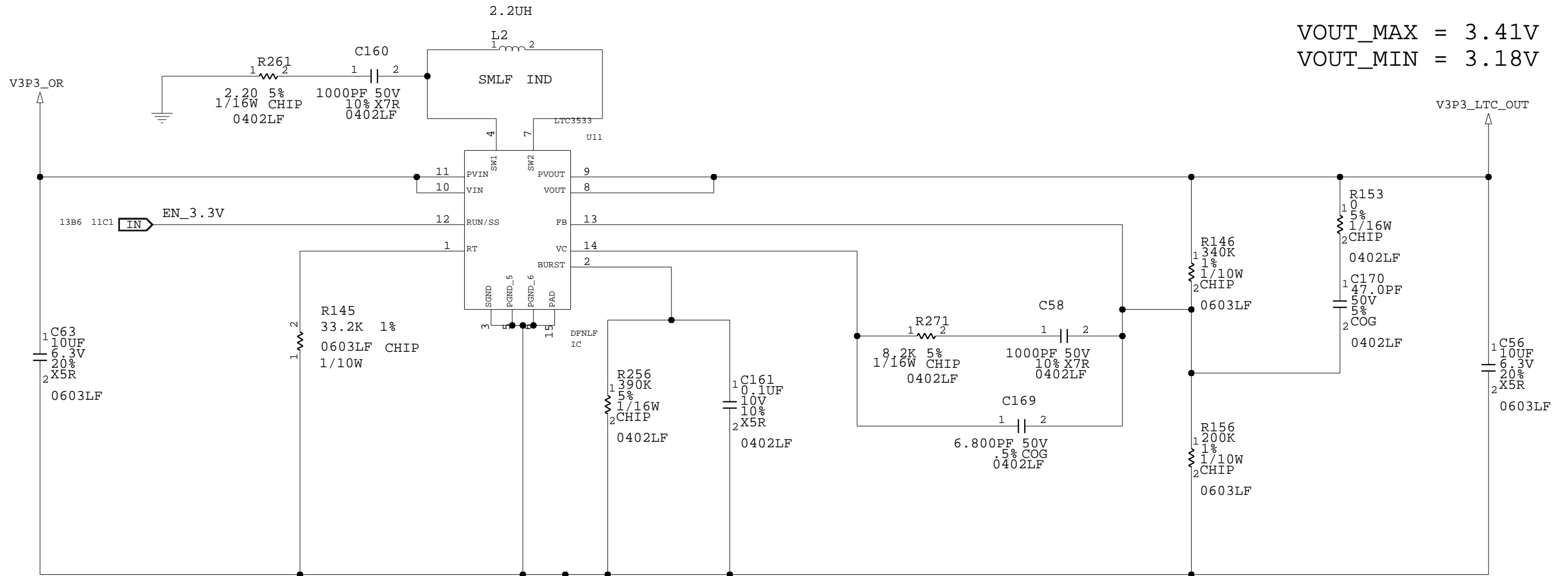

VOLTAGE BOOST REQUIRED TO COMPENSATE FOR  
VOLTAGE DROP FROM DIODE OR CIRCUIT. MANY DESIGNS  
MAY NOT REQUIRE A BOOST CIRCUIT.

$$I_{3533-MAX} = 1.5A$$

14 - 3.3V REGULATOR  
INTEL

LAN ACCESS DIVISION  
2111 N.E. 25th AVENUE  
HILLSBORO, OR 97124

TITLE 82580 REFERENCE DESIGN

SIZE  
B

CODE

DOCUMENT NUMBER

322445-007EN

REV  
2.2

DATE  
2010-06-25

SHEET  
14

# TPS73201 REGULATOR FOR 1.8V

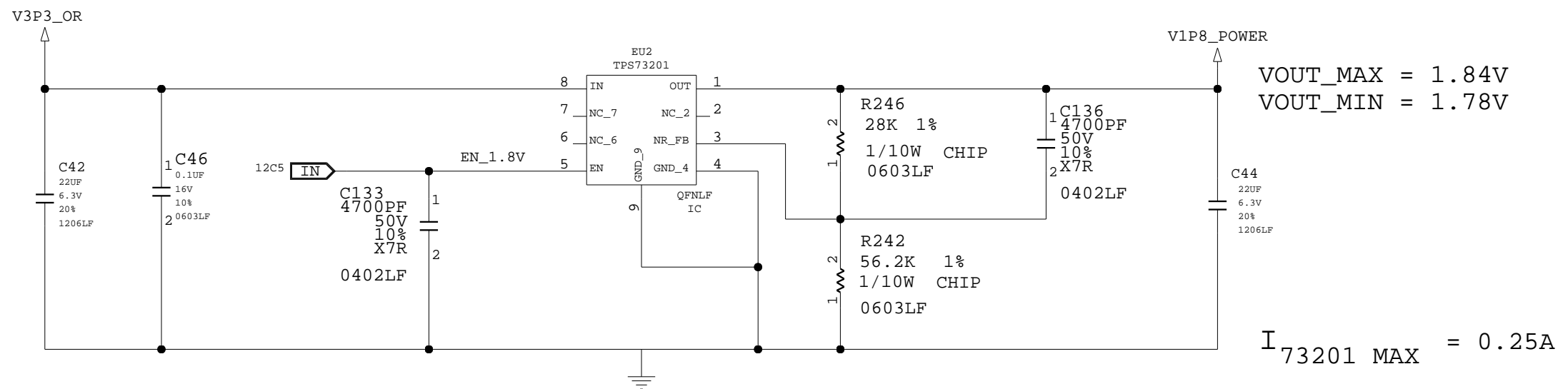

15 - 1.8V REGULATOR  
INTEL

LAN ACCESS DIVISION  
2111 N.E. 25th AVENUE  
HILLSBORO, OR 97124

TITLE 82580 REFERENCE DESIGN

SIZE  
B

CODE

DOCUMENT NUMBER

322445-007EN

REV  
2.2

DATE  
2010-06-25

SHEET  
15

# TPS40009 REGULATOR FOR 1.0V

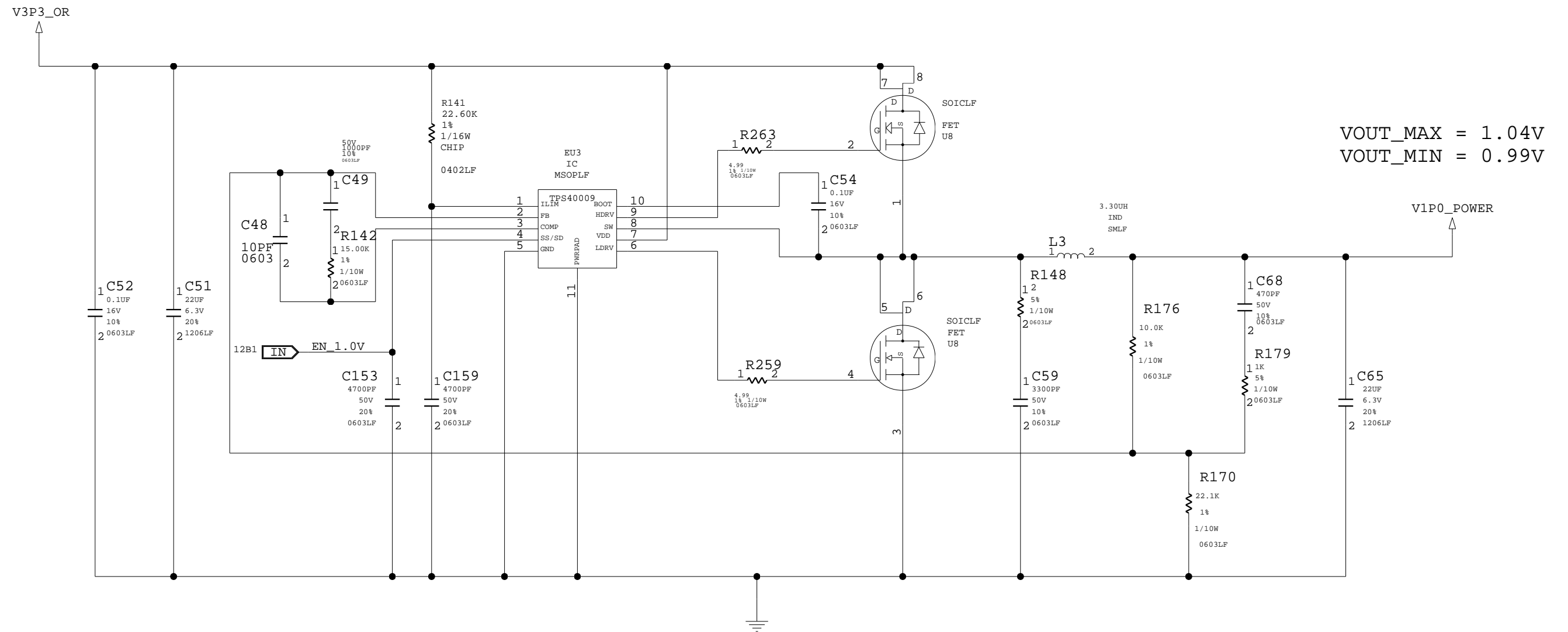

16 - 1.0V REGULATOR  
INTEL

LAN ACCESS DIVISION  
2111 N.E. 25th AVENUE  
HILLSBORO, OR 97124

TITLE 82580 REFERENCE DESIGN

SIZE  
B

CODE

DOCUMENT NUMBER

322445-007EN

REV  
2.2

DATE  
2010-06-25

SHEET  
16



# NC-SI TEST INTERFACE

TEST INTERFACE IS NOT REQUIRED IN A NORMAL DESIGN  
CONNECT NS-SI INTERFACE TO A MANAGEMENT CONTROLLER

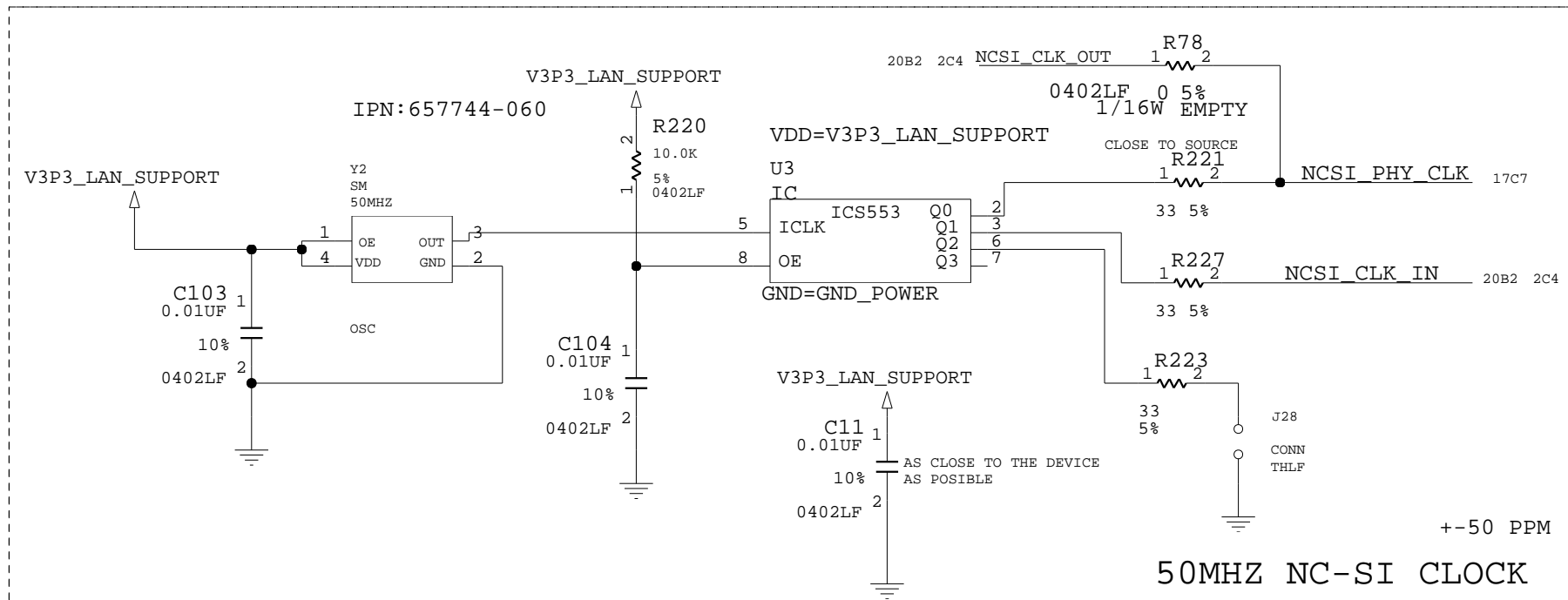
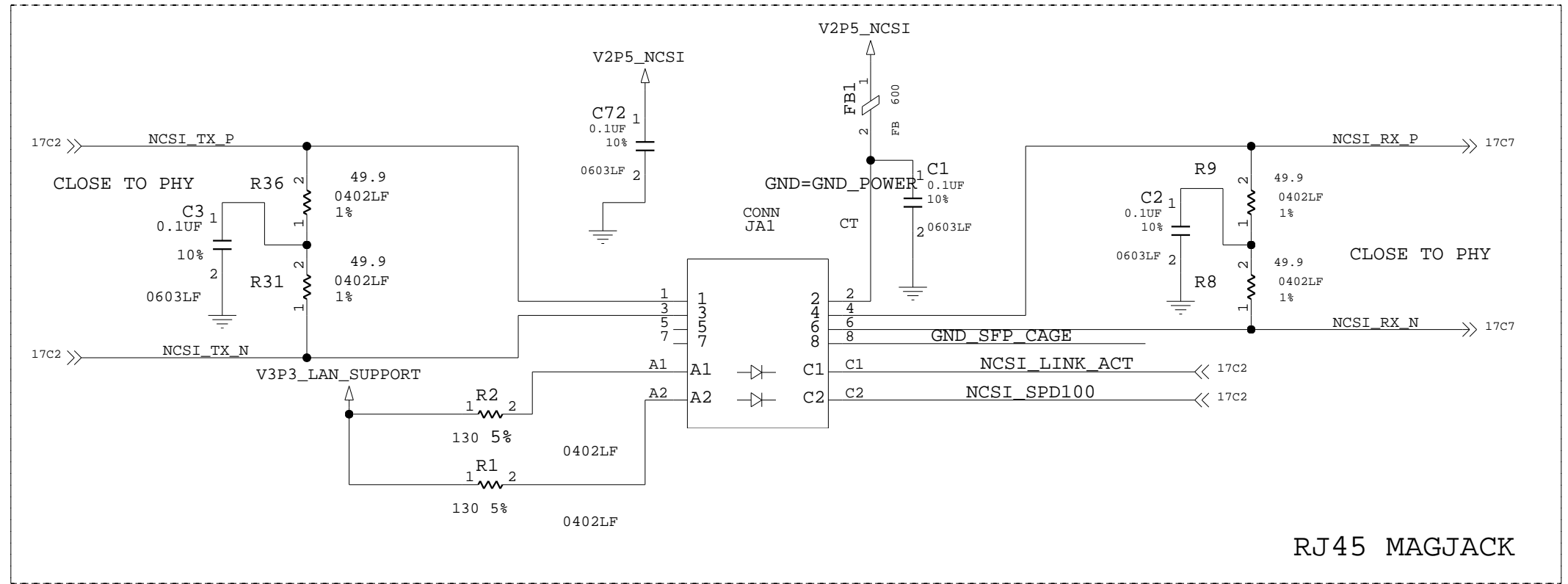

INTEL CONFIDENTIAL

UNKNOWN

LAN ACCESS DIVISION  
2111 N.E. 25th AVENUE  
HILLSBORO, OR 97124

TITLE 82580 REFERENCE DESIGN

SIZE B CODE DOCUMENT NUMBER 322445-007EN

REV 2.2

DATE 2010-06-25

SHEET 18

# TEST CONNECTORS SE

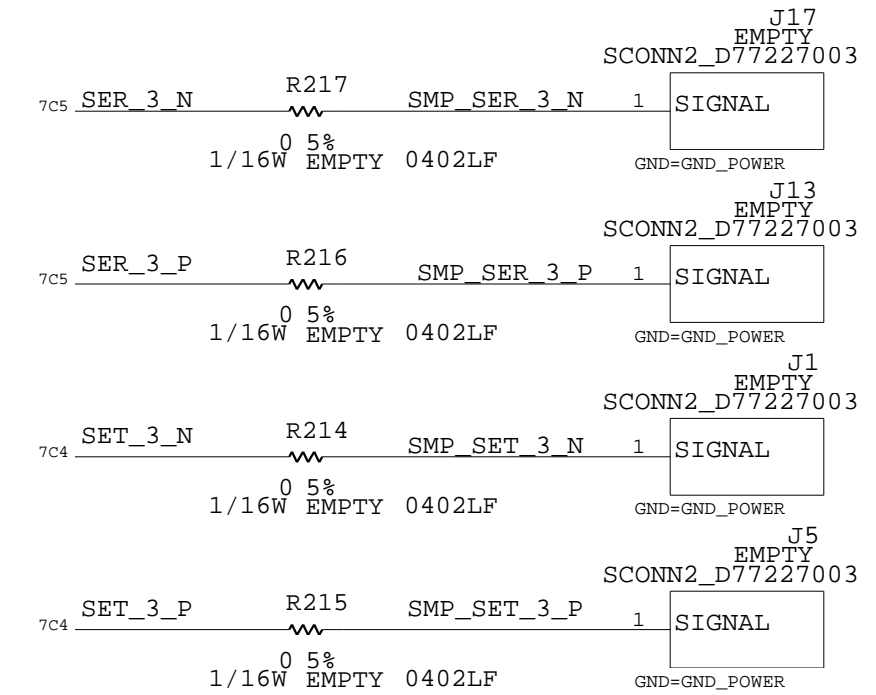
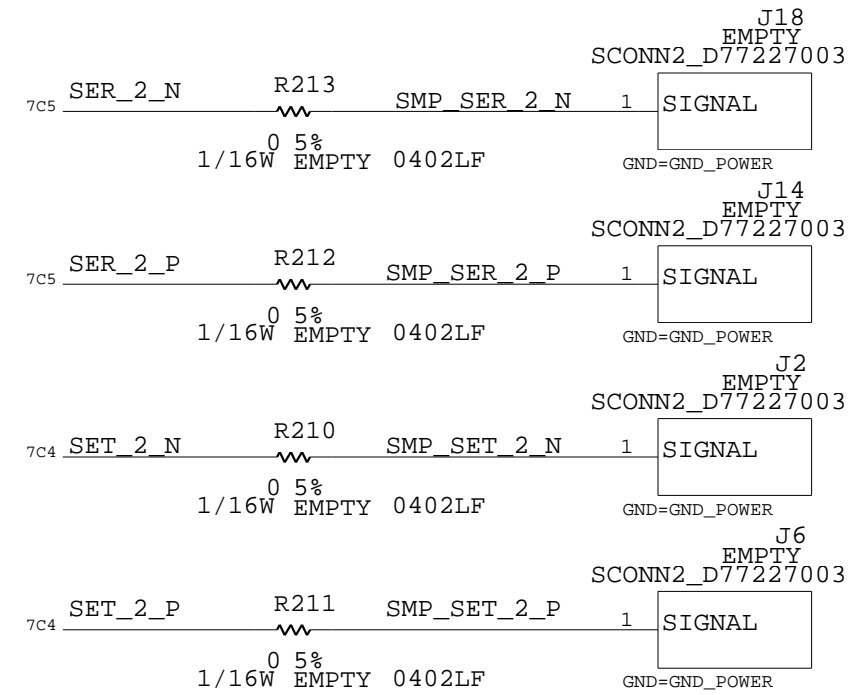
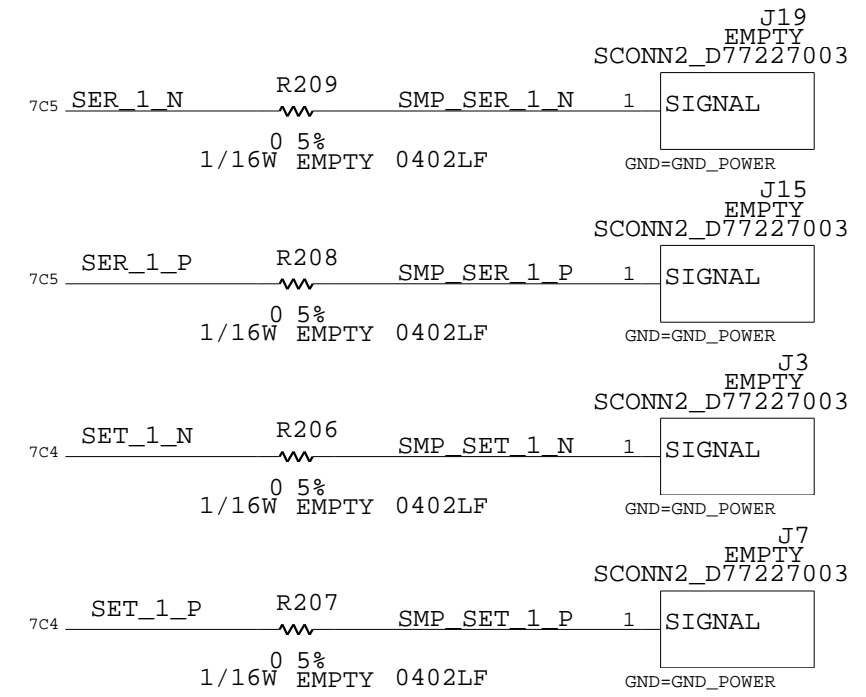
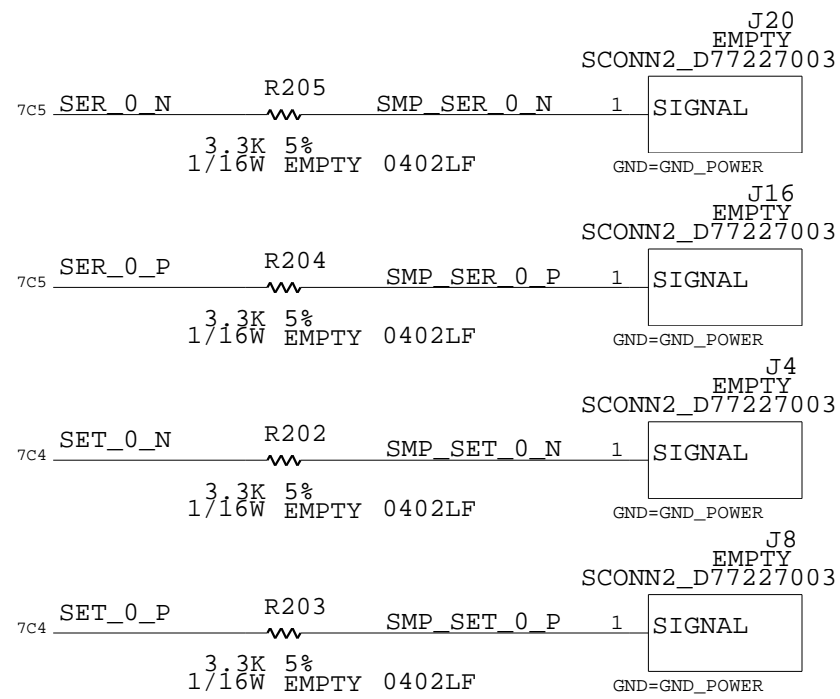

TEST INTERFACE IS NOT REQUIRED IN A NORMAL DESIGN

INTEL CONFIDENTIAL

UNKNOWN

LAN ACCESS DIVISION  
 2111 N.E. 25th AVENUE  
 HILLSBORO, OR 97124

TITLE 82580 REFERENCE DESIGN

SIZE  
B

CODE

DOCUMENT NUMBER

322445-007EN

REV  
2.2

DATE  
2010-06-25

SHEET  
19

# TEST CONNECTORS IO

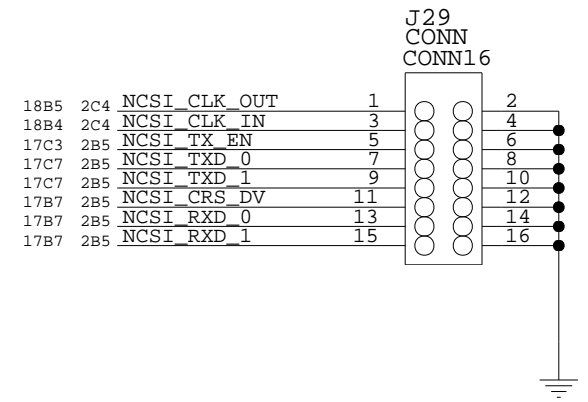
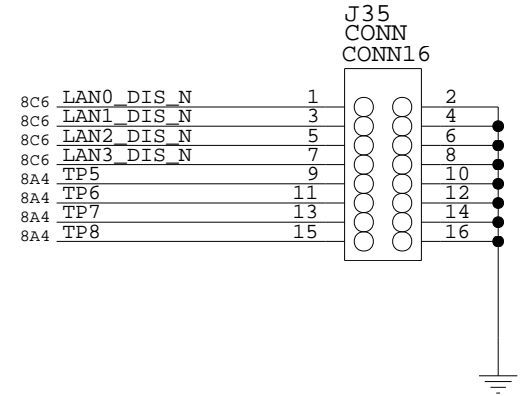
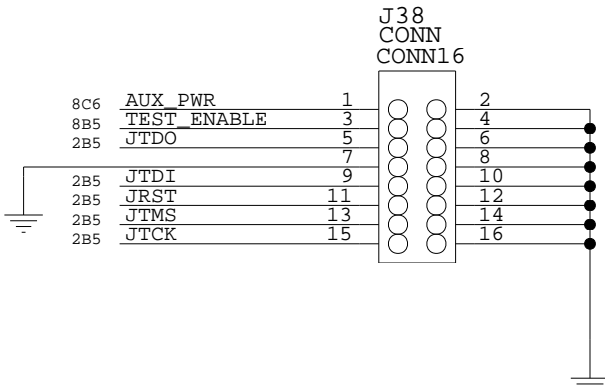
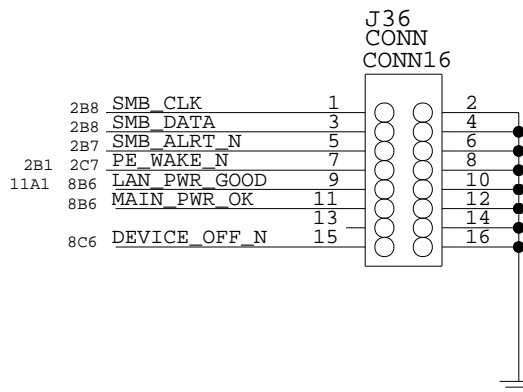
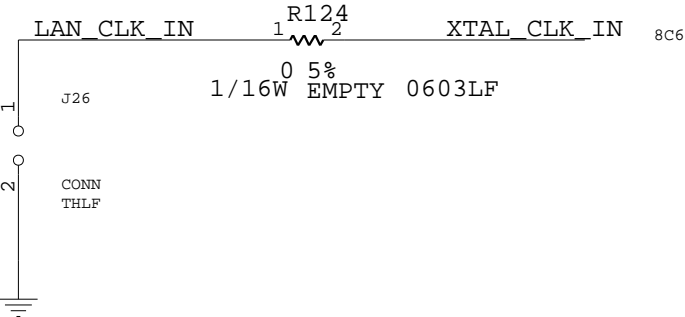
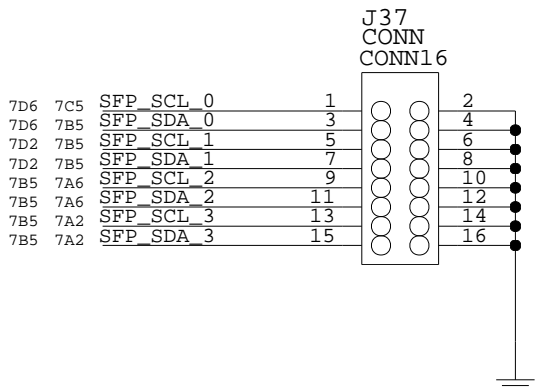
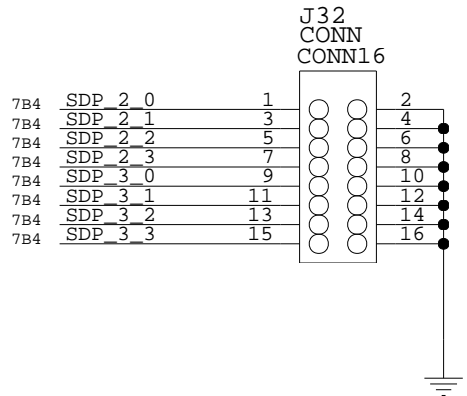
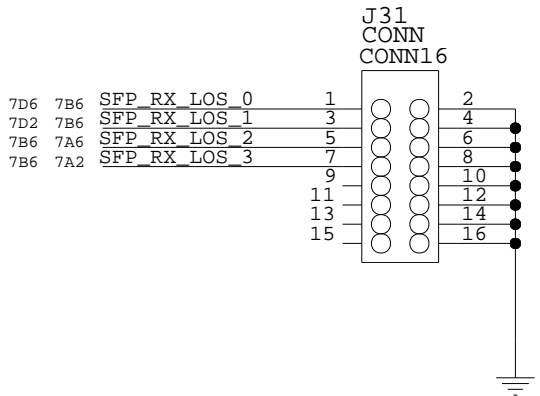
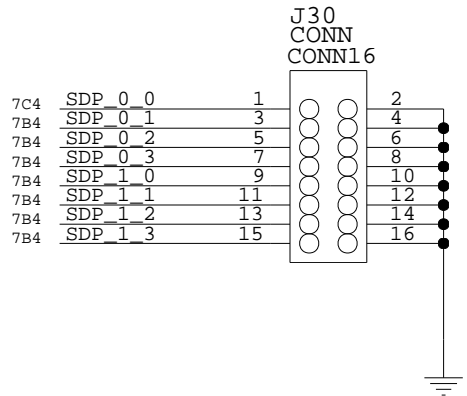

TEST INTERFACE IS NOT REQUIRED IN A NORMAL DESIGN

INTEL CONFIDENTIAL

UNKNOWN

LAN ACCESS DIVISION  
2111 N.E. 25th AVENUE  
HILLSBORO, OR 97124

TITLE 82580 REFERENCE DESIGN

SIZE B CODE DOCUMENT NUMBER

322445-007EN

REV 2.2

DATE 2010-06-25

SHEET 20

# MDI TVS DIODES

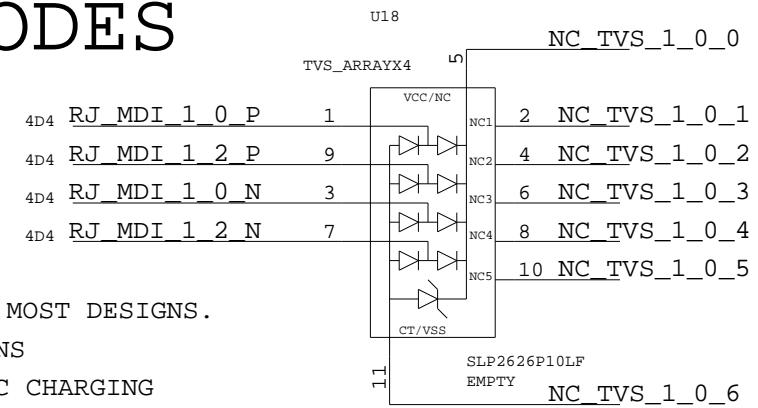
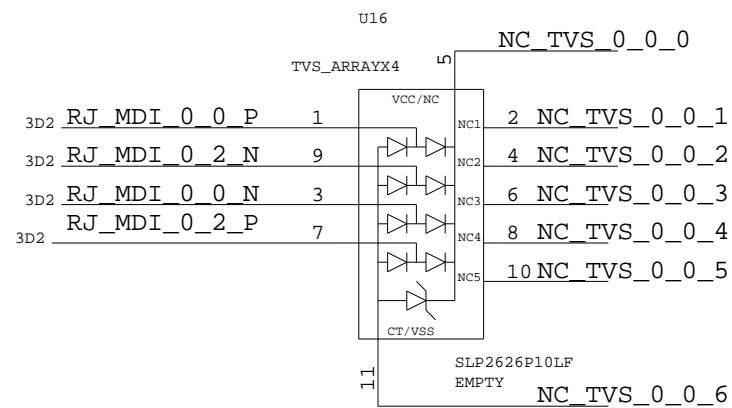

THESE DIODES ARE NOT REQUIRED IN MOST DESIGNS.  
 THEY ARE ONLY REQUIRED IN DESIGNS  
 WITH HIGH RISK FOR TRIBOELECTRIC CHARGING  
 SOME MOBILE DESIGN MIGHT REQUIRE THESE DIODES.

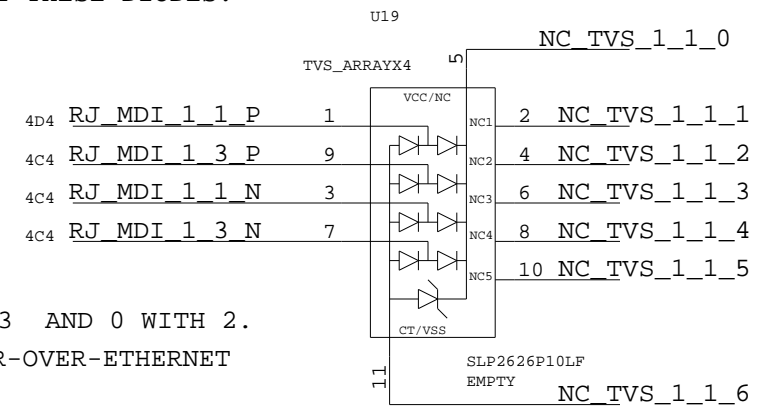
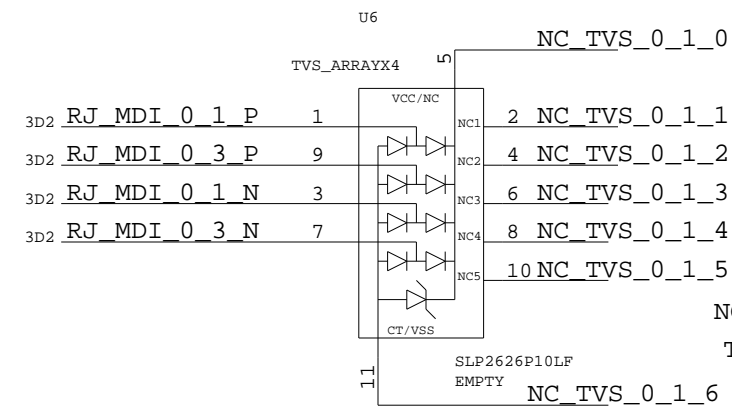

NOTE THAT THE PAIRS ARE GROUPED 1 WITH 3 AND 0 WITH 2.  
 THIS IS TO PREVENT A PROBLEM WITH POWER-OVER-ETHERNET  
 IMPLEMENTATIONS

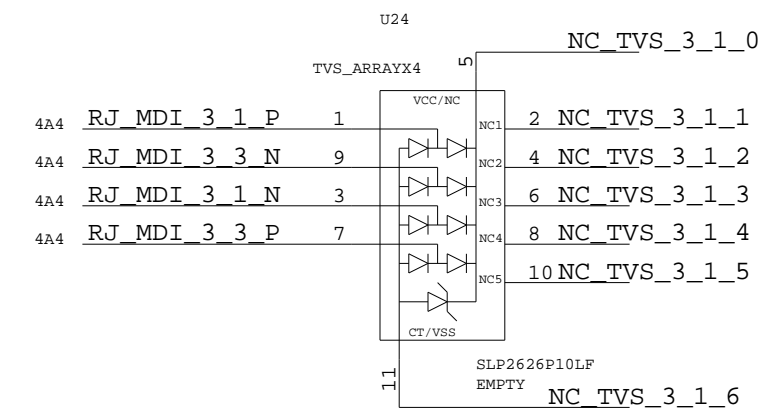
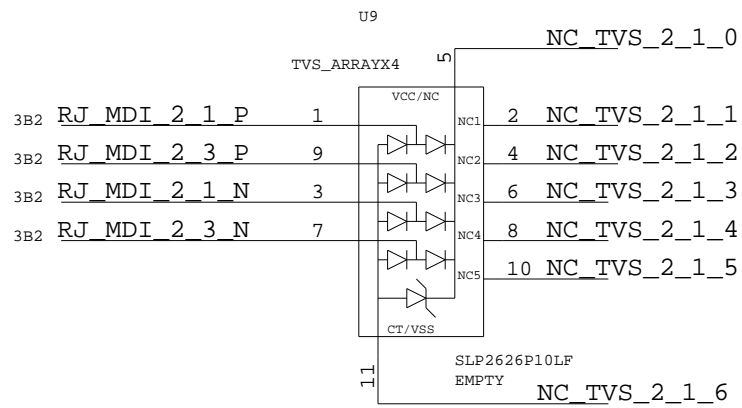
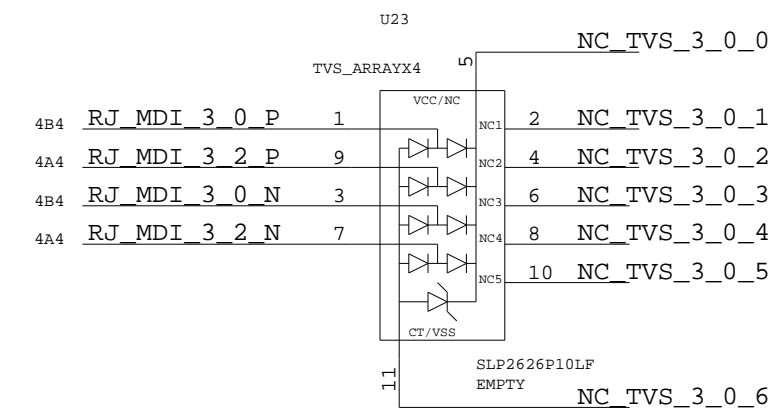
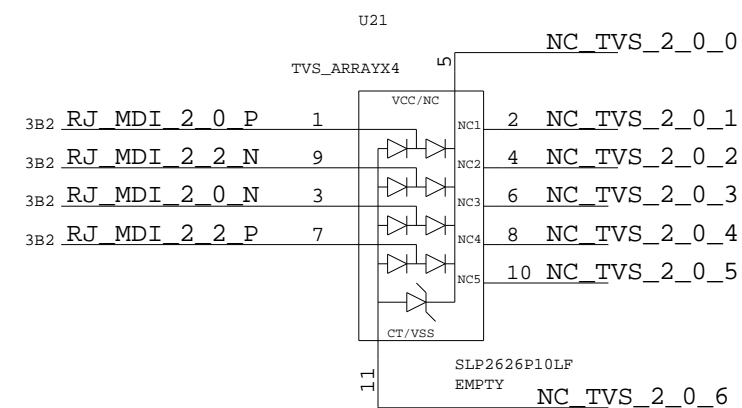

INTEL CONFIDENTIAL

UNKNOWN

LAN ACCESS DIVISION  
 2111 N.E. 25th AVENUE  
 HILLSBORO, OR 97124

TITLE 82580 REFERENCE DESIGN

SIZE  
B

CODE

DOCUMENT NUMBER

322445-007EN

REV  
2.2

DATE  
2010-06-25

SHEET  
21