

**Intel®
945(GM/GME)/915(GM/GME)/
855(GM/GME)/852(GM/GME)
Chipsets
VGA Port Always Enabled Hardware
Workaround**

White Paper

June 2007

INFORMATION IN THIS DOCUMENT IS PROVIDED IN CONNECTION WITH INTEL® PRODUCTS. NO LICENSE, EXPRESS OR IMPLIED, BY ESTOPPEL OR OTHERWISE, TO ANY INTELLECTUAL PROPERTY RIGHTS IS GRANTED BY THIS DOCUMENT. EXCEPT AS PROVIDED IN INTEL'S TERMS AND CONDITIONS OF SALE FOR SUCH PRODUCTS, INTEL ASSUMES NO LIABILITY WHATSOEVER, AND INTEL DISCLAIMS ANY EXPRESS OR IMPLIED WARRANTY, RELATING TO SALE AND/OR USE OF INTEL PRODUCTS INCLUDING LIABILITY OR WARRANTIES RELATING TO FITNESS FOR A PARTICULAR PURPOSE, MERCHANTABILITY, OR INFRINGEMENT OF ANY PATENT, COPYRIGHT OR OTHER INTELLECTUAL PROPERTY RIGHT. Intel products are not intended for use in medical, life saving, or life sustaining applications.

Intel may make changes to specifications and product descriptions at any time, without notice.

Designers must not rely on the absence or characteristics of any features or instructions marked "reserved" or "undefined." Intel reserves these for future definition and shall have no responsibility whatsoever for conflicts or incompatibilities arising from future changes to them.

The Intel® 945(GM/GME)/915(GM/GME)/855(GM/GME)/852(GM/GME) chipsets may contain design defects or errors known as errata which may cause the product to deviate from published specifications. Current characterized errata are available on request.

Contact your local Intel sales office or your distributor to obtain the latest specifications and before placing your product order.

Intel, Pentium, Xeon and the Intel logo are trademarks or registered trademarks of Intel Corporation or its subsidiaries in the United States and other countries.

*Other names and brands may be claimed as the property of others.

Copyright © 2006-2007, Intel Corporation. All rights reserved.

This device is protected by U.S. patent numbers 5,315,448 and 6,516,132, and other intellectual property rights. The use of Macrovision's copy protection technology in the device must be authorized by Macrovision and is intended for home and other limited pay-per-view uses only, unless otherwise authorized in writing by Macrovision. Devices incorporating Macrovision's copy protection technology can only be sold or distributed to companies appearing on Macrovision's list of "Authorized Buyers" at: www.macrovision.com. Reverse engineering or disassembly is prohibited."

Contents

1	Introduction	6
2	Description of Hardware Workaround	8
3	Schematic of Hardware Workaround	9

Revision History

Rev.	Description	Date
003	Modified for supporting 945GME and 915GME	June 2007
002	Added workarounds for 945, 852GM and 855GME chipsets	May 2006
001	Initial public release	April 2006

1 *Introduction*

1.1 **Purpose**

If a board containing the Intel® 945(GM/GME) Express Chipset, Intel® 915(GM/GME) Express Chipset, Intel® 855(GM/GME) chipset, or the Intel® 852(GM/GME) Chipset is booted up without a MONITOR attached, the MONITOR display will be disabled even if a MONITOR is attached after boot up.

This White Paper explains how to work around this problem so that a MONITOR can be enabled after boot up, which is necessary for applications which use the plug-and-play feature.

1.2 **Scope**

This paper is targeted for those who design for the 945(GM/GME)/915(GM/GME)/855(GM/GME)/852(GM/GME) Chipsets with the MONITOR plug-and-play feature.

2 ***Problem Description***

In some embedded applications, a MONITOR may be attached to the system after the boot up process has completed. When this occurs, the system boots up without the MONITOR attached during the POST and the VBIOS will disable the MONITOR output.

Under this condition, the MONITOR display will not work and the system will need to be rebooted with the MONITOR attached to enable the display.

The problem originates from the VBIOS of the Intel® Extreme Graphics Driver, which disables the MONITOR output if a MONITOR is not detected during POST.

3 ***Description of Hardware Workaround***

The Intel® 945(GM/GME)/915(GM/GME)/855(GM/GME)/852(GM/GME) Chipsets detect the presence of a MONITOR during POST by detecting 75 ohm pull-downs on the R/G/B signals located inside the MONITOR. These 75 ohm pull-downs near the Chipsets will change the equivalent resistance from 75 ohm to 37.5 ohm, and also change the DAC current of the chipset.

The 945(GM/GME)/915(GM/GME)/855(GM/GME)/852(GM/GME) will notify the VBIOS of the presence of the MONITOR by sensing whether the DAC current is changed. Based on the described MONITOR detection principle, a hardware workaround can be derived to tell the VBIOS of the Intel® Extreme Graphics Driver that the MONITOR is present even if it is unattached.

4 *Schematic of Hardware Workaround*

Note: This workaround is only necessary for platforms which use the Intel® Extreme Graphics Driver/VBIOS. This workaround is not necessary for platforms which use the Intel® Embedded Graphics Driver/VBIOS.

The workaround is accomplished by generating a 75 ohm pull-down enable/disable circuit on the board to tell the MONITOR detection of the POST that there is a MONITOR present.

The 75 ohm pull-downs would be enabled while the MONITOR is unattached, however, these 75 ohm pull-downs would be disabled while the MONITOR is attached.

A reference schematic is shown in Figure 1.

Figure 1 Intel® 945(GM/GME)/915(GM/GME)/855(GM/GME)/852(GM/GME) Chipsets Reference Schematic

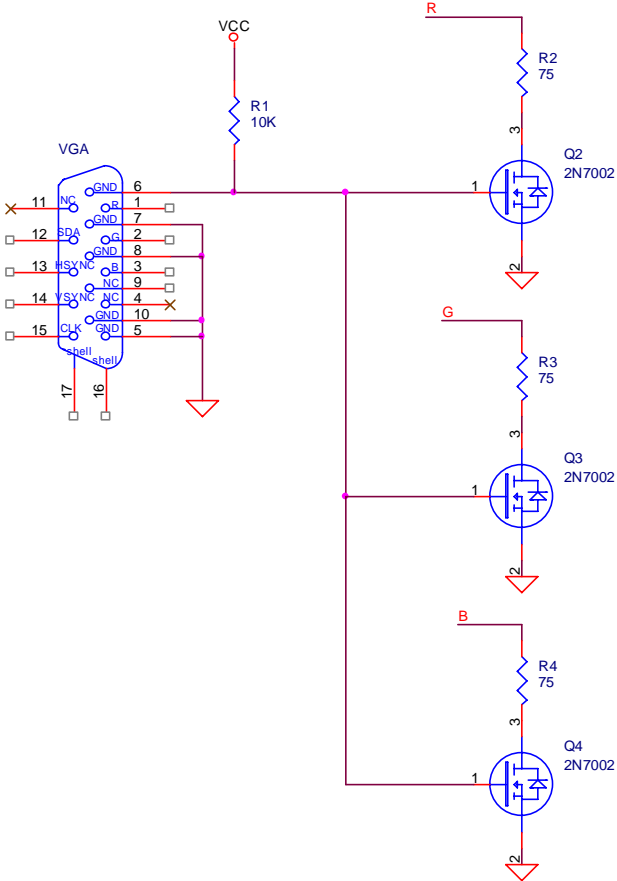

NOTES:

1. V_{CC} needs to be larger than NMOS VGS turn on voltage.