

Quad-Core Intel[®] Xeon[®] Processor L5318 in Embedded Applications

Thermal and Mechanical Design Guidelines

September 2007



INFORMATION IN THIS DOCUMENT IS PROVIDED IN CONNECTION WITH INTEL® PRODUCTS. NO LICENSE, EXPRESS OR IMPLIED, BY ESTOPPEL OR OTHERWISE, TO ANY INTELLECTUAL PROPERTY RIGHTS IS GRANTED BY THIS DOCUMENT. EXCEPT AS PROVIDED IN INTEL'S TERMS AND CONDITIONS OF SALE FOR SUCH PRODUCTS, INTEL ASSUMES NO LIABILITY WHATSOEVER, AND INTEL DISCLAIMS ANY EXPRESS OR IMPLIED WARRANTY, RELATING TO SALE AND/OR USE OF INTEL PRODUCTS INCLUDING LIABILITY OR WARRANTIES RELATING TO FITNESS FOR A PARTICULAR PURPOSE, MERCHANTABILITY, OR INFRINGEMENT OF ANY PATENT, COPYRIGHT OR OTHER INTELLECTUAL PROPERTY RIGHT. Intel products are not intended for use in medical, life saving, or life sustaining applications. Intel may make changes to specifications and product descriptions at any time, without notice.

Designers must not rely on the absence or characteristics of any features or instructions marked "reserved" or "undefined." Intel reserves these for future definition and shall have no responsibility whatsoever for conflicts or incompatibilities arising from future changes to them.

The Quad-Core Intel® Xeon® Processor 5300 Series may contain design defects or errors known as errata, which may cause the product to deviate from published specifications. Current characterized errata are available upon request.

Contact your local Intel sales office or your distributor to obtain the latest specifications and before placing your product order.

Copies of documents which have an order number and are referenced in this document, or other Intel literature, may be obtained by calling 1-800-548-4725, or by visiting Intel's website at <http://www.intel.com>.

Intel, Intel Inside, Xeon, Intel Core and the Intel logo are trademarks of Intel Corporation in the United States and other countries.

* Other brands and names may be claimed as the property of others.

Copyright © 2006-2007, Intel Corporation. All rights reserved.



Contents

1.0	Introduction	7
1.1	Objective	7
1.2	Scope	7
1.3	References	7
1.4	Definition of Terms	8
2.0	Thermal/Mechanical Reference Design	10
2.1	Mechanical Requirements	10
2.1.1	Processor Mechanical Parameters	10
2.1.2	Quad-Core Intel® Xeon® Processor 5300 Series Package	10
2.1.3	Quad-Core Intel® Xeon® Processor 5300 Series Considerations	15
2.2	Processor Thermal Parameters and Features	15
2.2.1	Thermal Control Circuit and TDP	15
2.2.2	Digital Thermal Sensor	17
2.2.3	Platform Environmental Control Interface (PECI)	17
2.2.4	Multiple Core Special Considerations	18
2.2.5	Thermal Profile	21
2.2.6	TCONTROL Definition	22
2.2.7	Performance Targets	23
2.3	Characterizing Cooling Solution Performance Requirements	25
2.3.1	Fan Speed Control	25
2.3.2	Processor Thermal Characterization Parameter Relationships	27
2.3.3	Chassis Thermal Design Considerations	29
2.4	Thermal/Mechanical Reference Design Considerations	29
2.4.1	Heatsink Solutions	29
2.4.2	Thermal Interface Material	30
2.4.3	Summary	30
2.4.4	Assembly Overview of the Intel Reference Thermal Mechanical Design	32
2.4.5	AdvancedTCA Thermal Solution Performance	34
2.4.6	Components Overview	35
A	Mechanical Drawings	38
B	Heatsink Clip Load Methodology	50
B.1	Overview	50
B.2	Test Preparation	50
B.2.1	Heatsink Preparation	50
B.2.2	Typical Test Equipment	53
B.2.3	Test Procedure Examples	53
B.2.4	Time-Zero, Room Temperature Preload Measurement	53
B.2.5	Preload Degradation under Bake Conditions	54
C	Safety Requirements	55
D	Quality and Reliability Requirements	56
D.1	Intel Verification Criteria for the Reference Designs	56
D.1.1	Reference Heatsink Thermal Verification	56
D.1.2	Environmental Reliability Testing	56
D.1.3	Material and Recycling Requirements	58
E	Enabled Suppliers Information	59
E.1	Supplier Information	59
E.1.1	Intel Enabled Suppliers	59



Figures

1	Quad-Core Intel® Xeon® Processor 5300 Series Mechanical Drawing (1 of 3).....	12
2	Quad-Core Intel® Xeon® Processor 5300 Series Mechanical Drawing (2 of 3).....	13
3	Quad-Core Intel® Xeon® Processor 5300 Series Mechanical Drawing (3 of 3).....	14
4	Processor Case Temperature Measurement Location.....	16
5	DTS Domain for Quad-Core Intel® Xeon® Processor 5300 Series	18
6	Processor Core Geometric Center Locations.....	20
7	Thermal Profile Diagram	21
8	TCONTROL Value and Digital Thermal Sensor Value Interaction.....	22
9	TCONTROL and Thermal Profile Interaction.....	23
10	Thermal Profile for the Quad-Core Intel® Xeon® Processor L5318	24
11	TCONTROL and Fan Speed Control	26
12	Processor Thermal Characterization Parameter Relationships	28
13	Exploded View of CEK Thermal Solution Components.....	32
14	AdvancedTCA CEK Heatsink Thermal Performance.....	34
15	Isometric View of the ATCA Heatsink	35
16	CEK Spring Isometric View.....	36
17	Isometric View of CEK Spring Attachment to the Base Board	37
18	AdvancedTCA* CEK Heatsink (Sheet 1 of 3)	39
19	AdvancedTCA* CEK Heatsink (Sheet 2 of 3)	40
20	AdvancedTCA* CEK Heatsink (Sheet 3 of 3)	41
21	CEK Spring (Sheet 1 of 3).....	42
22	CEK Spring (Sheet 2 of 3).....	43
23	CEK Spring (Sheet 3 of 3).....	44
24	Baseboard Keepout Footprint Definition and Height Restrictions for Enabling Components (Sheet 1 of 5)	45
25	Baseboard Keepout Footprint Definition and Height Restrictions for Enabling Components (Sheet 2 of 5)	46
26	Baseboard Keepout Footprint Definition and Height Restrictions for Enabling Components (Sheet 3 of 5)	47
27	Baseboard Keepout Footprint Definition and Height Restrictions for Enabling Components (Sheet 4 of 5)	48
28	Baseboard Keepout Footprint Definition and Height Restrictions for Enabling Components (Sheet 5 of 5)	49
29	Load Cell Installation in Machined Heatsink Base Pocket - Bottom View.....	51
30	Load Cell Installation in Machined Heatsink Base Pocket - Side View	52
31	Preload Test Configuration	52



Tables

1	Reference Documents	7
2	Terms and Descriptions	8
3	Processor Mechanical Parameters Table	10
4	Input and Output Conditions for the Quad-Core Intel® Xeon® Processor 5300 Series Thermal Management Features	19
5	Processor Core Geometric Center Dimensions	20
6	Intel Reference Heatsink Performance Targets for the Quad-Core Intel® Xeon® Processor L5318 Series	25
7	Fan Speed Control, TCONTROL and DTS Relationship	26
8	CEK Heatsink Thermal Mechanical Characteristics	36
9	Mechanical Drawing List	38
10	Typical Test Equipment	53
11	Use Conditions Environment	57
12	Suppliers for the Dual-Core Intel Xeon Processor 5300 Series Intel Reference Solution	59



Revision History

Revision Number	Description	Date
001	• Initial public release of this document.	September 2007

§



1.0 Introduction

1.1 Objective

The purpose of this guide is to describe the reference thermal solution and design parameters required for the Quad-Core Intel® Xeon® processor L5318 (40W TDP skus). These processors are thermally-optimized and provide optimal performance in small form factors like AdvancedTCA under NEBS conditions. It is also the intent of this document to comprehend and demonstrate the processor cooling solution features and requirements. Furthermore, this document provides an understanding of the processor thermal characteristics, and discusses guidelines for meeting the thermal requirements imposed on the entire life of the processor. The thermal/mechanical solutions described in this document are intended to aid component and system designers in the development and evaluation of processor compatible thermal/mechanical solutions.

1.2 Scope

The thermal/mechanical solution described in this document pertain to a solution intended for use with the Quad-Core Intel® Xeon® processor L5318 in AdvancedTCA* form factors systems. This document contains the mechanical and thermal requirements of the processor cooling solution. In case of conflict, the data in the *Quad-Core Intel® Xeon® Processor 5300 Series Electrical, Mechanical, and Thermal Specifications (EMTS)* supersedes any data in this document. Additional information is provided as a reference in the appendices. For other Quad-Core Intel® Xeon® processor 5300 series in 1U, 2U, 2U+ and workstation form factors systems refer to the *Quad-Core Intel® Xeon® processor 5300 series Thermal/Mechanical Design Guide*.

1.3 References

Material and concepts available in the following documents may be beneficial when reading this document.

Table 1. Reference Documents (Sheet 1 of 2)

Document	Comment
<i>European Blue Angel Recycling Standards</i>	http://www.blauer-engel.de
<i>Intel® Xeon® Processor Family Thermal Test Vehicle User's Guide</i>	See Note at bottom table.
<i>Intel® Xeon® Processor Thermal Design Guidelines</i>	http://developer.intel.com/
<i>LGA771 Socket Mechanical Design Guide</i>	See Note following table.
<i>LGA771 SMT Socket Design Guidelines</i>	See Note following table.
<i>LGA771 Daisy Chain Test Vehicle User Guide</i>	See Note following table.
<i>Quad-Core Intel® Xeon® Processor-Based Servers Platform Design Guide (PDG)</i>	See Note following table.
<i>Stoakley Platform Design Guide (PDG)</i>	See Note following table.
<i>PECI Feature Set Overview</i>	See Note following table

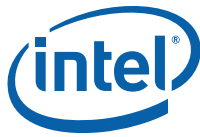

Table 1. Reference Documents (Sheet 2 of 2)

Document	Comment
<i>Platform Environment Control Interface(PECI) Specification</i>	See Note following table
<i>Quad-Core Intel® Xeon® Processor 5300 Series Electrical, Mechanical, and Thermal Specifications (EMTS)</i>	See Note following table.
<i>Quad-Core Intel® Xeon® Processor 5300 Series_Enabled_CEK_and_Package_Mechanical_Models</i> (in IGES and ProE* format)	Available electronically
<i>Quad-Core Intel® Xeon® Processor 5300 Series_Enabled_CEK_Thermal_Models</i> (in Flotherm* and Icepak*)	Available electronically
<i>Quad-Core Intel® Xeon® Processor 5300 Series_Package_Thermal_Models</i> (in Flotherm* and Icepak*)	Available electronically
<i>Quad-Core Intel® Xeon® Processor 5300 Series_Thermal/Mechanical Design Guideline</i>	Available electronically
<i>Conroe and Woodcrest Processor Family BIOS Writer's Guide (BWG)</i>	See Note following table.
<i>Thin Electronics Bay Specification (A Server System Infrastructure (SSI) Specification for Rack Optimized Servers</i>	www.ssiforum.com

Note: Contact your Intel field sales representative for the latest revision and order number of this document.

1.4 Definition of Terms

Table 2. Terms and Descriptions (Sheet 1 of 2)

Term	Description
Bypass	Bypass is the area between a passive heatsink and any object that can act to form a duct. For this example, it can be expressed as a dimension away from the outside dimension of the fins to the nearest surface.
DTS	Digital Thermal Sensor replaces the Tdiode in previous products and uses the same sensor as the PROCHOT# sensor to indicate the on-die temperature. The temperature value represents the number of degrees below the TCC activation temperature.
MSR	The processor provides a variety of model specific registers that are used to control and report on processor performance. Virtually all MSRs handle system related functions and are not accessible to an application program.
FMB	Flexible Motherboard Guideline: an estimate of the maximum value of a processor specification over certain time periods. System designers should meet the FMB values to ensure their systems are compatible with future processor releases.
FSC	Fan Speed Control
IHS	Integrated Heat Spreader: a component of the processor package used to enhance the thermal performance of the package. Component thermal solutions interface with the processor at the IHS surface.
LGA771 Socket	The Quad-Core Intel® Xeon® processor 5300 series interface to the baseboard through this surface mount, 771 Land socket. See the <i>LGA771 Socket Mechanical Design Guide</i> for details regarding this socket.
NEBS	Network Equipment Building Systems. Family of documents that implement directives from the Telecommunications Act of 1996 relative to industry wide general requirements for telecommunications and customer premise equipment.
P _{MAX}	The maximum power dissipated by a semiconductor component.
PECI	A proprietary one-wire bus interface that provides a communication channel between Intel processor and chipset components to external thermal monitoring devices, for use in fan speed control. Peci communicates readings from the processors Digital Thermal Sensor. Peci replaces the thermal diode available in previous processors.
Ψ _{CA}	Case-to-ambient thermal characterization parameter (psi). A measure of thermal solution performance using total package power. Defined as (T _{CASE} - T _{LA}) / Total Package Power. Heat source should always be specified for Ψ measurements.



Table 2. Terms and Descriptions (Sheet 2 of 2)

Term	Description
Ψ_{CS}	Case-to-sink thermal characterization parameter. A measure of thermal interface material performance using total package power. Defined as $(T_{CASE} - T_S) / \text{Total Package Power}$.
Ψ_{SA}	Sink-to-ambient thermal characterization parameter. A measure of heatsink thermal performance using total package power. Defined as $(T_S - T_{LA}) / \text{Total Package Power}$.
T_{CASE}	The case temperature of the processor, measured at the geometric center of the topside of the IHS.
$T_{CASE-MAX}$	The maximum case temperature as specified in a component specification.
TCC	Thermal Control Circuit: Thermal monitor uses the TCC to reduce the die temperature by using clock modulation and/or operating frequency and input voltage adjustment when the die temperature is very near its operating limits.
$T_{CONTROL}$	A processor unique value for use in fan speed control mechanisms. $T_{CONTROL}$ is a temperature specification based on a temperature reading from the processor's Digital Thermal Sensor. $T_{CONTROL}$ can be described as a trigger point for fan speed control implementation. $T_{CONTROL} = -T_{OFFSET}$.
T_{OFFSET}	An offset value from the TCC activation temperature value specified in the processor EMTS or data sheet and $T_{CONTROL} = -T_{OFFSET}$. This value is programmed into each processor during manufacturing and can be obtained by reading the IA_32_TEMPERATURE_TARGET MSR. This is a static and a unique value. Refer to the <i>Conroe and Woodcrest Processor Family BIOS Writer's Guide (BWG)</i> .
TDP	Thermal Design Power: Thermal solution should be designed to dissipate this target power level. TDP is not the maximum power that the processor can dissipate.
Thermal Monitor	A feature on the processor that can keep the processor's die temperature within factory specifications under normal operating conditions, and with a thermal solution that satisfies the processor thermal profile specification.
Thermal Profile	Line that defines case temperature specification of a processor at a given power level.
TIM	Thermal Interface Material: The thermally conductive compound between the heatsink and the processor case. This material fills the air gaps and voids, and enhances the transfer of the heat from the processor case to the heatsink.
T_{LA}	The measured ambient temperature locally surrounding the processor. The ambient temperature should be measured just upstream of a passive heatsink or at the fan inlet for an active heatsink.
T_{SA}	The system ambient air temperature external to a system chassis. This temperature is usually measured at the chassis air inlets.
U	A unit of measure used to define server rack spacing height. 1U is equal to 1.75 in, 2U equals 3.50 in, etc.

§



2.0 Thermal/Mechanical Reference Design

This chapter describes the thermal/mechanical reference design for Quad-Core Intel® Xeon® processor 5300 series. The Quad-Core Intel® Xeon® processor L5300 series is a power-optimized processor with a front side bus speed of 1066 MHz or 1333 MHz. The Quad-Core Intel® Xeon® processor L5318 is targeted for volumetrically constrained form factors (AdvancedTCA).

2.1 Mechanical Requirements

The mechanical performance of the processor cooling solution must satisfy the requirements described in this section.

2.1.1 Processor Mechanical Parameters

Table 3. Processor Mechanical Parameters Table

Parameter	Minimum	Maximum	Unit	Notes
Volumetric Requirements and Keepouts				1
Static Compressive Load				3
Static Board Deflection				3
Dynamic Compressive Load				3
Transient Bend				3
Shear Load		70 311	lbf N	2,4,5
Tensile Load		25 111	lbf N	2,4,6
Torsion Load		35 3.95	in*lbf N*m	2,4,7

Notes:

1. Refer to drawings in [Appendix A](#).
2. In the case of a discrepancy, the most recent *Quad-Core Intel® Xeon® Processor 5300 Series Electrical, Mechanical and Thermal Specification (EMTS)* and *LGA771 Socket Mechanical Design Guide* supersede targets listed in [Table 3](#) above.
3. These socket limits are defined in the *LGA771 Socket Mechanical Design Guide*.
4. These package handling limits are defined in the *Quad-Core Intel® Xeon® Processor 5300 Series Electrical, Mechanical and Thermal Specification (EMTS)*.
5. Shear load that can be applied to the package IHS.
6. Tensile load that can be applied to the package IHS.
7. Torque that can be applied to the package IHS.

2.1.2 Quad-Core Intel® Xeon® Processor 5300 Series Package

The Quad-Core Intel® Xeon® processor 5300 series is packaged using the flip-chip land grid array (FC-LGA6) package technology. Please refer to the *Quad-Core Intel® Xeon® Processor 5300 Series Electrical, Mechanical and Thermal Specification (EMTS)*

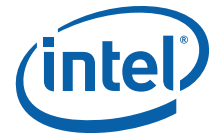

for detailed mechanical specifications. The Quad-Core Intel® Xeon® processor 5300 series Mechanical drawings shown in [Figure 1](#), [Figure 2](#) and [Figure 3](#) provide the mechanical information for Quad-Core Intel® Xeon® processor 5300 series. The stackup height of the processors in the socket is shown in [Appendix A](#). The drawing is superseded with the drawing in the processor EMTS, should there be any conflicts. Integrated package/socket stackup height information is provided in the *LGA771 Socket Mechanical Design Guide*.

The package includes an integrated heat spreader (IHS). The IHS transfers the non-uniform heat from the die to the top of the IHS, out of which the heat flux is more uniform and spreads over a larger surface area (not the entire IHS area). This allows more efficient heat transfer out of the package to an attached cooling device. The IHS is designed to be the interface for contacting a heatsink. Details can be found in the *Quad-Core Intel® Xeon® Processor 5300 Series Electrical, Mechanical and Thermal Specification (EMTS)*.

The processor connects to the baseboard through a 771-land surface mount socket. A description of the socket can be found in the *LGA771 Socket Mechanical Design Guide*.

The processor package and socket have mechanical load limits that are specified in the *Quad-Core Intel® Xeon® Processor 5300 Series Electrical, Mechanical, and Thermal Specifications (EMTS)* and the *LGA771 Socket Mechanical Design Guide*. These load limits should not be exceeded during heatsink installation, removal, mechanical stress testing, or standard shipping conditions. For example, when a compressive static load is necessary to ensure thermal performance of the Thermal Interface Material (TIM) between the heatsink base and the IHS, it should not exceed the corresponding specification given in the *LGA771 Socket Mechanical Design Guide*.

The heatsink mass can also add additional dynamic compressive load to the package during a mechanical shock event. Amplification factors due to the impact force during shock must be taken into account in dynamic load calculations. The total combination of dynamic and static compressive load should not then exceed the processor/socket compressive dynamic load specified in the *LGA771 Socket Mechanical Design Guide* during a vertical shock. It is not recommended to use any portion of the processor substrate as a mechanical reference or load-bearing surface in either static or dynamic compressive load conditions.



Figure 2. Quad-Core Intel® Xeon® Processor 5300 Series Mechanical Drawing (2 of 3)

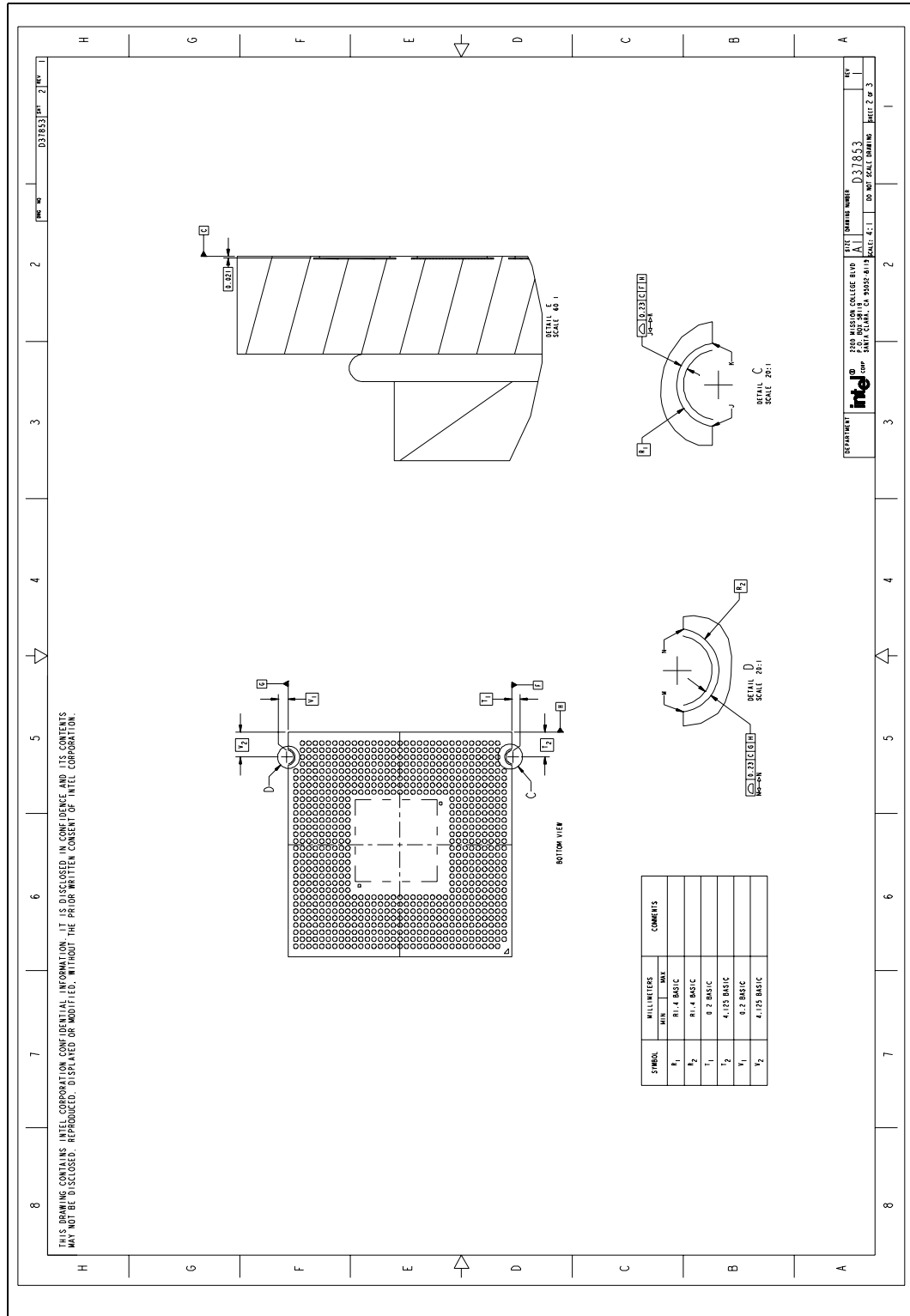
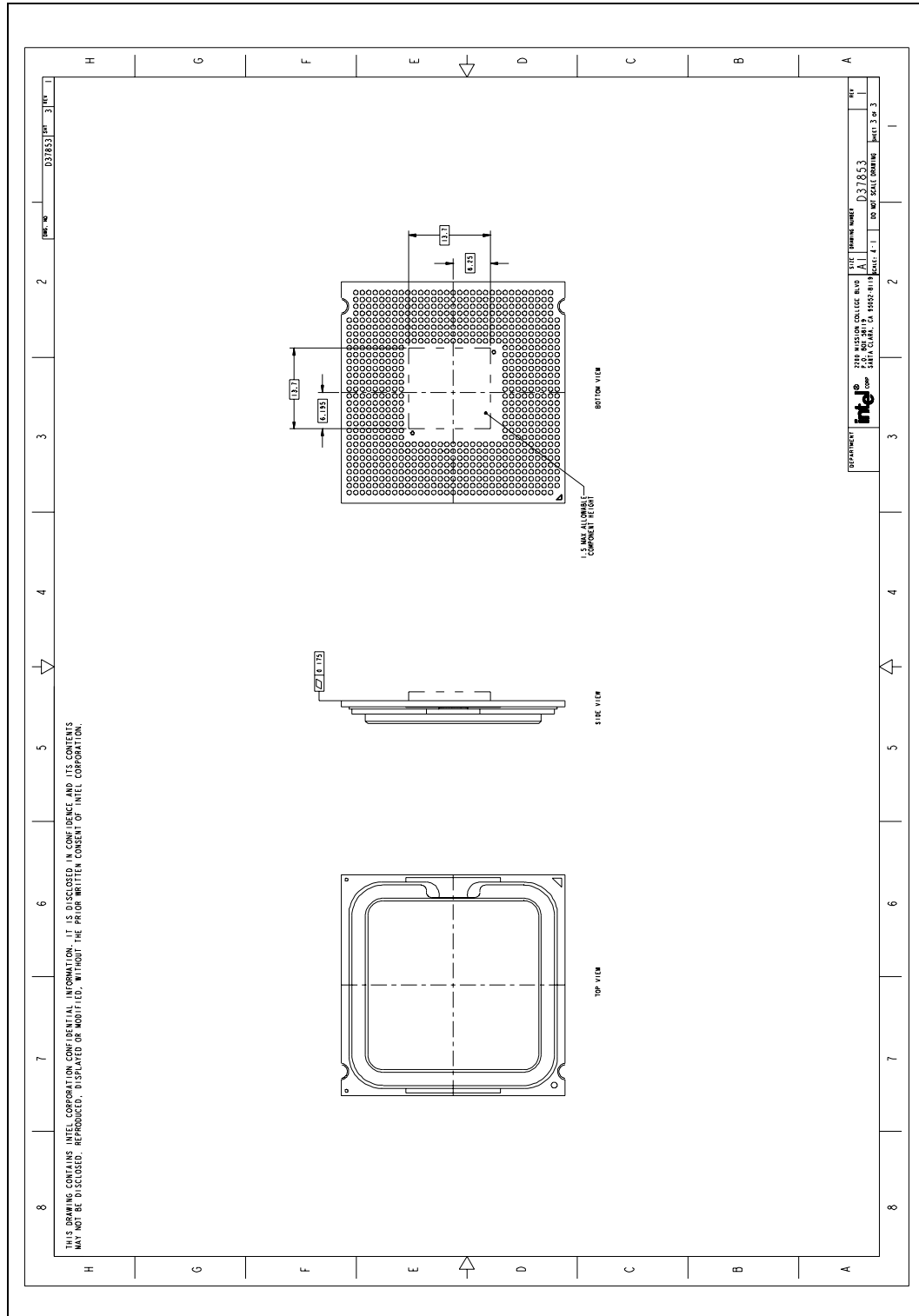
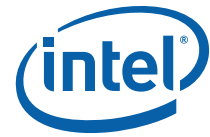



Figure 3. Quad-Core Intel® Xeon® Processor 5300 Series Mechanical Drawing (3 of 3)





2.1.3 Quad-Core Intel® Xeon® Processor 5300 Series Considerations

An attachment mechanism must be designed to support the heatsink since there are no features on the LGA771 socket to directly attach a heatsink. In addition to holding the heatsink in place on top of the IHS, this mechanism plays a significant role in the robustness of the system in which it is implemented, in particular:

- Ensuring thermal performance of the TIM applied between the IHS and the heatsink. TIMs, especially ones based on phase change materials, are very sensitive to applied pressure: the higher the pressure, the better the initial performance. TIMs such as thermal greases are not as sensitive to applied pressure. Refer to [Section 2.4.2](#) and [Section 2.4.6.2](#) for information on tradeoffs made with TIM selection. Designs should consider possible decrease in applied pressure over time due to potential structural relaxation in enabled components.
- Ensuring system electrical, thermal, and structural integrity under shock and vibration events. The mechanical requirements of the attach mechanism depend on the weight of the heatsink and the level of shock and vibration that the system must support. The overall structural design of the baseboard and system must be considered when designing the heatsink attach mechanism. Their design should provide a means for protecting LGA771 socket solder joints as well as preventing package pullout from the socket.

Note: The load applied by the attachment mechanism must comply with the package and socket specifications, along with the dynamic load added by the mechanical shock and vibration requirements, as identified in [Section 2.1.1](#).

A potential mechanical solution for heavy heatsinks is the direct attachment of the heatsink to the chassis pan. In this case, the strength of the chassis pan can be utilized rather than solely relying on the baseboard strength. In addition to the general guidelines given above, contact with the baseboard surfaces should be minimized during installation in order to avoid any damage to the baseboard.

The Intel reference design for Quad-Core Intel® Xeon® processor 5300 series is using such a heatsink attachment scheme. Refer to [Section 2.4](#) for further information regarding the Intel reference mechanical solution.

2.2 Processor Thermal Parameters and Features

2.2.1 Thermal Control Circuit and TDP

The operating thermal limits of the processor are defined by the Thermal Profile. The intent of the Thermal Profile specification is to support acoustic noise reduction through fan speed control and ensure the long-term reliability of the processor. This specification requires that the temperature at the center of the processor IHS, known as (T_{CASE}) remains within a certain temperature specification. For illustration, [Figure 4](#) shows the measurement location for the Quad-Core Intel® Xeon® processor 5300 series package. Compliance with the T_{CASE} specification is required to achieve optimal operation and long-term reliability (See the *Intel® Xeon® Processor Family Thermal Test Vehicle User's Guide* for Case Temperature definition and measurement methods).

Figure 4. Processor Case Temperature Measurement Location

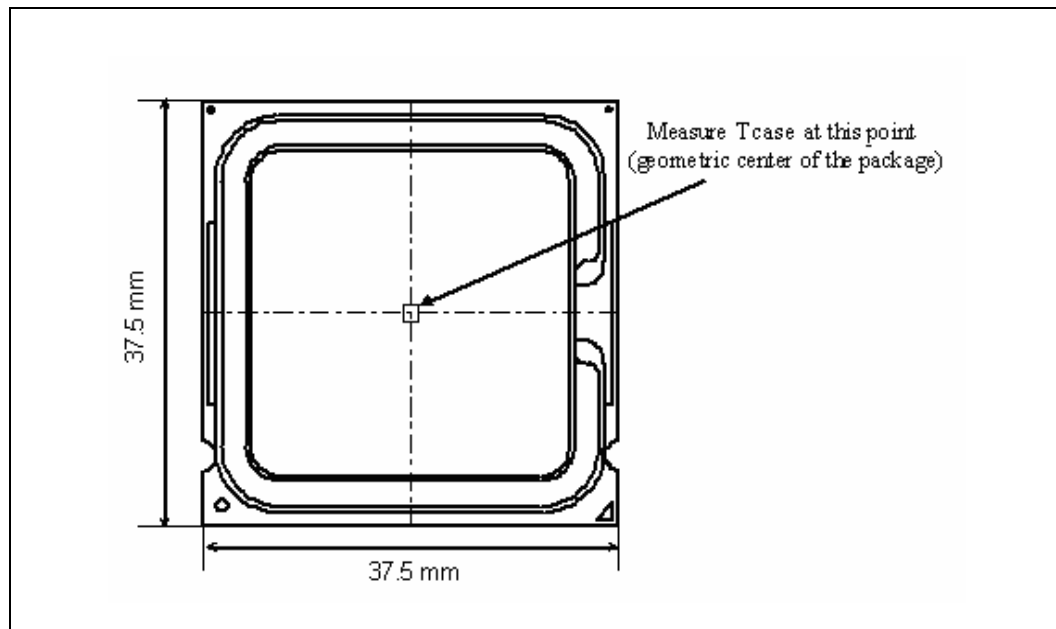

To ease the burden on thermal solutions, the Thermal Monitor feature and associated logic have been integrated into the silicon of the processor. One feature of the Thermal Monitor is the Thermal Control Circuit (TCC). When active, the TCC lowers the processor temperature by reducing power consumption. This is accomplished through a combination of Thermal Monitor and Advanced Thermal Monitor (TM2). Thermal Monitor modulates the duty cycle of the internal processor clocks, resulting in a lower effective frequency. When active, the TCC turns the processor clocks off and then back on with a predetermined duty cycle. Thermal Monitor 2 activation adjusts both the processor operating frequency (via the bus multiplier) and input voltage (via the VID signals). Please refer to the *Quad-Core Intel® Xeon® Processor 5300 Series Electrical, Mechanical, and Thermal Specifications (EMTS)* for further details on TM and TM2.

PROCHOT# is designed to assert at or a few degrees higher than maximum T_{CASE} (as specified by the thermal profile) when dissipating TDP power, and can not be interpreted as an indication of processor case temperature. This temperature delta accounts for processor package, lifetime, and manufacturing variations and attempts to ensure the Thermal Control Circuit is not activated below maximum T_{CASE} when dissipating TDP power. There is no defined or fixed correlation between the PROCHOT# assertion temperature and the case temperature. However, with the introduction of the Digital Thermal Sensor (DTS) on the Quad-Core Intel® Xeon® processor 5300 series, the DTS reports a relative temperature delta below the PROCHOT# assertion temperature (see [Section 2.2.2](#) for more details on the Digital Thermal Sensor). Thermal solutions must be designed to the processor specifications (i.e Thermal Profile) and can not be adjusted based on experimental measurements of T_{CASE} , PROCHOT#, or Digital Thermal Sensor on random processor samples.

By taking advantage of the Thermal Monitor features, system designers may reduce thermal solution cost by designing to the Thermal Design Power (TDP) instead of maximum power. TDP should be used for processor thermal solution design targets. TDP is not the maximum power that the processor can dissipate. TDP is based on measurements of processor power consumption while running various high power applications. This data set is used to determine those applications that are interesting from a power perspective. These applications are then evaluated in a controlled thermal environment to determine their sensitivity to activation of the thermal control



circuit. This data set is then used to derive the TDP targets published in the processors EMTS. The Thermal Monitor can protect the processors in rare workload excursions above TDP. Therefore, thermal solutions should be designed to dissipate this target power level. The thermal management logic and thermal monitor features are discussed in extensive detail in the *Quad-Core Intel® Xeon® Processor 5300 Series Electrical, Mechanical and Thermal Specification (EMTS)*.

In addition, on-die thermal management features called THERMTRIP# and FORCEPR# are available on the Quad-Core Intel® Xeon® processor 5300 series. They provide a thermal management approach to support the continued increases in processor frequency and performance. Please see the *Quad-Core Intel® Xeon® Processor 5300 Series Electrical, Mechanical, and Thermal Specifications (EMTS)* for guidance on these thermal management features.

2.2.2 Digital Thermal Sensor

The Quad-Core Intel® Xeon® processor 5300 series include on-die temperature sensor feature called Digital Thermal Sensor (DTS). The DTS uses the same sensor utilized for TCC activation. Each individual processor is calibrated so that TCC activation occurs at a DTS value of 0. The temperature reported by the DTS is the relative offset in PECCI counts below the onset of the TCC activation temperature and hence is negative. Changes in PECCI counts are roughly linear in relation to temperature changes in degrees Celsius. For example, a change in PECCI count by '1' represents a change in temperature of approximately 1°C. However, this linearity cannot be guaranteed as the offset below TCC activation exceeds 20-30 PECCI counts. Also note that the DTS will not report any values above the TCC activation temperature, it will simply return 0 in this case.

The DTS also facilitates the use of multiple thermal sensors within the processor without the burden of increasing the number of thermal sensor signal pins on the processor package. Operation of multiple DTS will be discussed more detail in [Section 2.2.4](#). Also, the DTS utilizes thermal sensors that are optimally located when compared with thermal diodes available with legacy processors. This is achieved as a result of a smaller foot print and decreased sensitivity to noise. These DTS benefits will result in more accurate fan speed control and TCC activation. The DTS application in fan speed control will be discussed more detail in [Section 2.3.1](#).

2.2.3 Platform Environmental Control Interface (PECCI)

The PECCI interface is designed specifically to convey system management information from the processor (initially, only thermal data from the Digital Thermal Sensor). It is a proprietary single wire bus between the processor and the chipset or other health monitoring device. The PECCI specification provides a specific command set to discover, enumerate devices, and read the temperature. For an overview of the PECCI interface, please refer to *PECCI Feature Set Overview*. For more detail information on PECCI, please refer to *Platform Environment Control Interface (PECCI) Specification* and *Quad-Core Intel® Xeon® Processor 5300 Series Electrical, Mechanical and Thermal Specifications (EMTS)*.

2.2.4 Multiple Core Special Considerations

2.2.4.1 Multiple Digital Thermal Sensor Operation

Each Quad-Core Intel® Xeon® processor 5300 series processor can have multiple Digital Thermal Sensors located on the die. Each die within the processor currently maps to a PECL domain. The Quad-Core Intel® Xeon® processor 5300 series contains two dies (Domains) and each die contains two cores. BIOS will be responsible for detecting the proper processor type and providing the number of domains to the thermal management system. An external PECL device that is part of the thermal management system polls the processor domains for temperature information and currently receives the highest of the DTS output temperatures within each domain. [Figure 5](#) provides an illustration of the DTS domains for the Quad-Core Intel® Xeon® processor 5300 series.

Figure 5. DTS Domain for Quad-Core Intel® Xeon® Processor 5300 Series

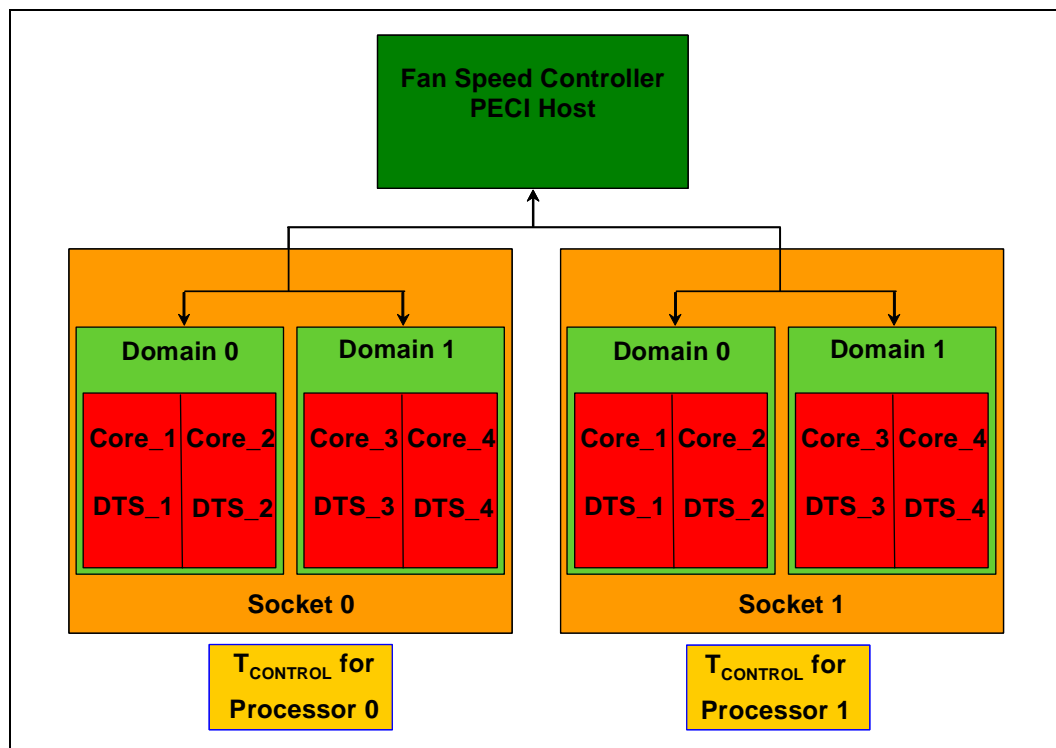

2.2.4.2 Thermal Monitor for Multiple Core Products

The thermal management for multiple core products has only one $T_{CONTROL}$ value per processor. The $T_{CONTROL}$ for processor 0 and $T_{CONTROL}$ for processor 1 are independent from each other. If the DTS temperature from any domain within the processor is greater than or equal to $T_{CONTROL}$, the processor case temperature must remain at or below the temperature as specified by the thermal profile. See [Section 2.2.6](#) for information on $T_{CONTROL}$. The PECL signal is available through CPU pin (G5) on each LAG771 socket for the Quad-Core Intel® Xeon® processor 5300 series. Through this pin, the dual domains receive all temperature sensor values and provide the current hottest value to an external PECL device such as a thermal management system.



2.2.4.3 PROCHOT#, THERMTRIP#, and FORCEPR#

The PROCHOT# and THERMTRIP# outputs will be shared by all cores on a processor. The first core to reach TCC activation will assert PROCHOT#. A single FORCEPR# input will be shared by every core. Table 4 provides an overview of input and output conditions for the Quad-Core Intel® Xeon® processor 5300 series thermal management features.

Table 4. Input and Output Conditions for the Quad-Core Intel® Xeon® Processor 5300 Series Thermal Management Features

Item	Processor Input	Processor Output
TM1/TM2	DTSCore X > TCC Activation Temperature	All Cores TCC Activation
PROCHOT#	DTSCore X ≥ TCC Activation Temperature	PROCHOT# Asserted
THERMTRIP#	DTSCore X ≥ THERMTRIP # Assertion Temperature	THERMTRIP# Asserted, all cores shut down
FORCEPR#	FORCEPR# Asserted	All Cores TCC Activation

Notes:

1. X=1,2,3,4; represents any one of the core1, core2, core3 and core4 in Quad-Core Intel® Xeon® processor 5300 series.
2. For more information on PROCHOT#, THERMTRIP#, and FORCEPR# see the *Quad-Core Intel® Xeon® Processor 5300 Series Electrical, Mechanical and Thermal Specification (EMTS)*

2.2.4.4 Heatpipe Orientation for Multiple Core Processors

Thermal management of multiple core processors can be achieved without the use of heatpipe heatsinks, as demonstrated by the Intel Reference Thermal Solution discussed in Section 2.4.

To assist customers interested in designing heatpipe heatsinks, processor core locations have been provided. In some cases, this may influence the designer’s selection of heatpipe orientation. For this purpose, the core geometric center locations, as illustrated in Figure 6, are provided in Table 5. Dimensions originate from the vertical edge of the IHS nearest to the pin 1 fiducial as shown in Figure 6.

Figure 6. Processor Core Geometric Center Locations

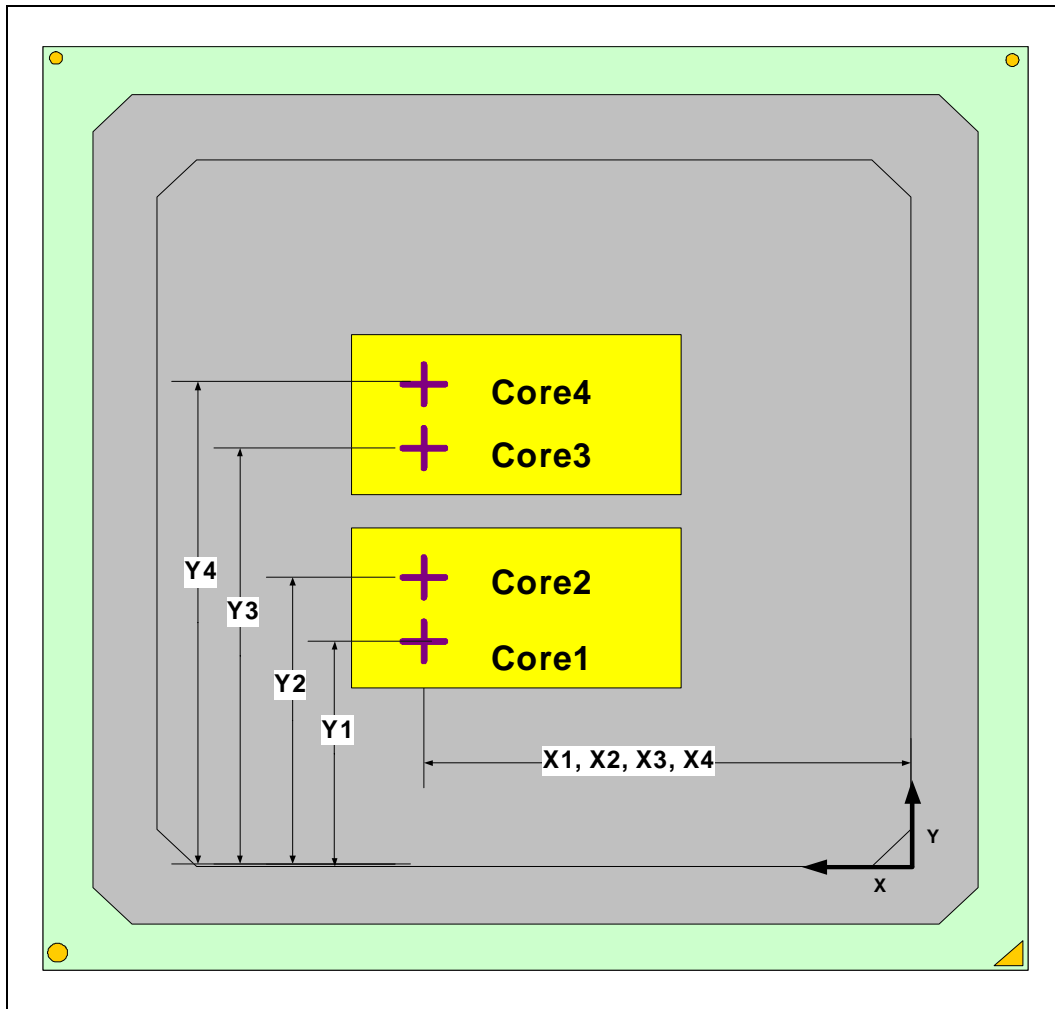
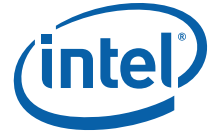

Table 5. Processor Core Geometric Center Dimensions

Feature	X Dimension	Y Dimension
Core 1	19.53 mm	6.41 mm
Core 2	19.53 mm	10.56 mm
Core 3	19.53 mm	18.94 mm
Core 4	19.53 mm	23.09 mm



2.2.5 Thermal Profile

The thermal profile is a linear line that defines the relationship between a processor’s case temperature and its power consumption as shown in Figure 7. The equation of the thermal profile is defined as:

Equation 1. $y = ax + b$

Where:

- y = Processor case temperature, T_{CASE} (°C)
- x = Processor power consumption (W)
- a = Case-to-ambient thermal resistance, Ψ_{CA} (°C/W)
- b = Processor local ambient temperature, T_{LA} (°C)

Figure 7. Thermal Profile Diagram

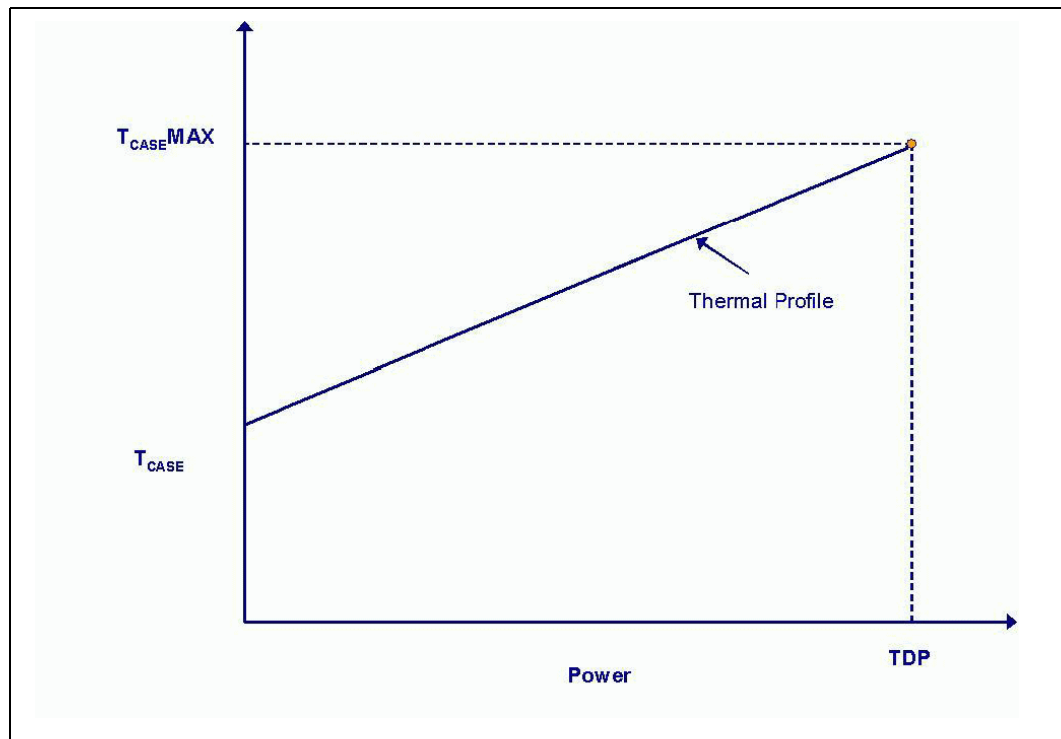

The high end point of the Thermal Profile represents the processor’s TDP and the associated maximum case temperature (T_{CASE_MAX}). The lower end point of the Thermal Profile represents the power value ($P_{PROFILE_MIN}$) and the associated case temperature ($T_{CASE_MAX@ P_{PROFILE_MIN}}$) for the lowest possible theoretical value of $T_{CONTROL}$ (see Section 2.2.6). The slope of the Thermal Profile line represents the case-to-ambient resistance of the thermal solution with the y-intercept being the local processor ambient temperature. The slope of the Thermal Profile is constant between $P_{PROFILE_MIN}$ and TDP, which indicates that all frequencies of a processor defined by the Thermal Profile will require the same heatsink case-to-ambient resistance.

In order to satisfy the Thermal Profile specification, a thermal solution must be at or below the Thermal Profile line for the given processor when its DTS temperature is greater than $T_{CONTROL}$ (refer to Section 2.2.6). The Thermal Profile allows the customers to make a trade-off between the thermal solution case-to-ambient resistance and the processor local ambient temperature that best suits their platform



implementation (refer to Section 2.3.3). There can be multiple combinations of thermal solution case-to-ambient resistance and processor local ambient temperature that can meet a given Thermal Profile. If the case-to-ambient resistance and the local ambient temperature are known for a specific thermal solution, the Thermal Profile of that solution can easily be plotted against the Thermal Profile specification. As explained above, the case-to-ambient resistance represents the slope of the line and the processor local ambient temperature represents the y-axis intercept. Hence the T_{CASE} values of a specific solution can be calculated at the TDP and $P_{PROFILE_MIN}$ power levels. Once these points are determined, they can be joined by a line, which represents the Thermal Profile of the specific solution. If that line stays at or below the Thermal Profile specification, then that particular solution is deemed as a compliant solution.

2.2.6 $T_{CONTROL}$ Definition

$T_{CONTROL}$ can be described as a trigger point for fan speed control implementation. The processor $T_{CONTROL}$ value provided by the Digital Thermal Sensor is relative and no longer absolute, the $T_{CONTROL}$ value is now defined as a relative value to the TCC activation set point (i.e. PECCI Count = 0), as indicated by PROCHOT#. Figure 8 depicts the interaction between the $T_{CONTROL}$ value and Digital Thermal Sensor value.

Figure 8. $T_{CONTROL}$ Value and Digital Thermal Sensor Value Interaction

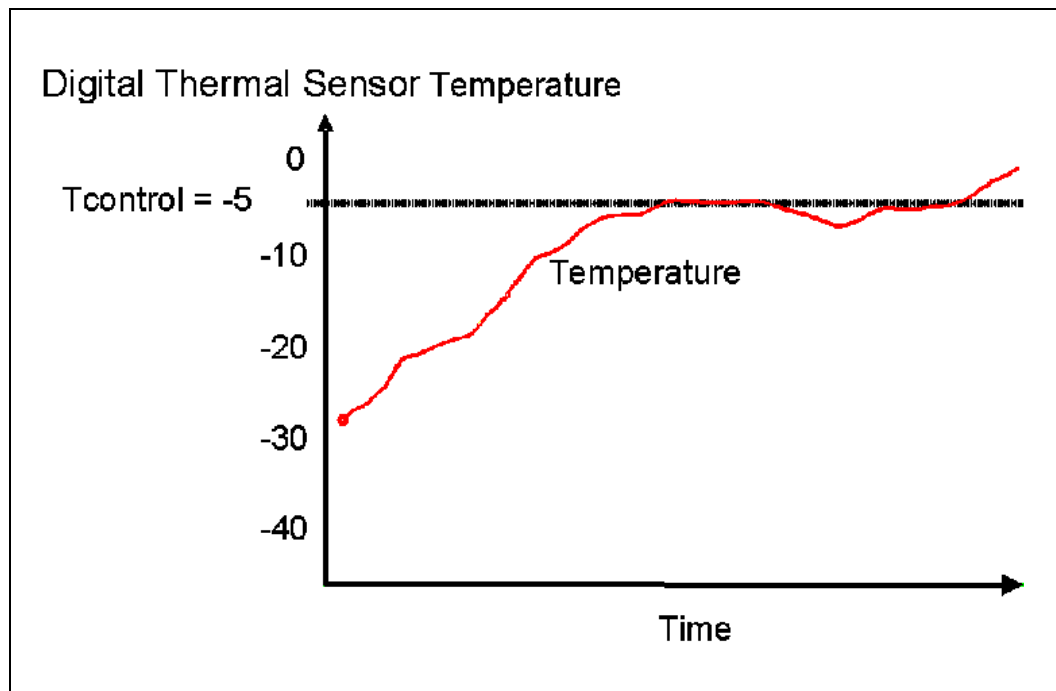

The value for $T_{CONTROL}$ is calibrated in manufacturing and configured for each processor individually. For the Quad-Core Intel® Xeon® processor 5300 series, the $T_{CONTROL}$ value is obtained by reading a processor model specific register (IA32_TEMPERATURE_TARGET MSR).

Note: There is no $T_{CONTROL_BASE}$ value to sum as previously required on legacy processors. The fan speed control device only needs to read the T_{OFFSET} MSR and compare this to the DTS value from the PECCI interface. The equation for calculating $T_{CONTROL}$ is:

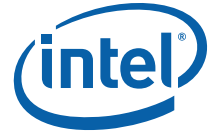

Equation 2. $T_{CONTROL} = -T_{OFFSET}$

Where:

T_{OFFSET} = A DTS-based value programmed into each processor during manufacturing that can be obtained by reading the IA32_TEMPERATURE_TARGET MSR. This is a static and a unique value. Refer to the *Conroe and Woodcrest Processor Family BIOS Writer's Guide (BWG)* for further details.

Figure 9 depicts the interaction between the Thermal Profile and $T_{CONTROL}$.

Figure 9. $T_{CONTROL}$ and Thermal Profile Interaction

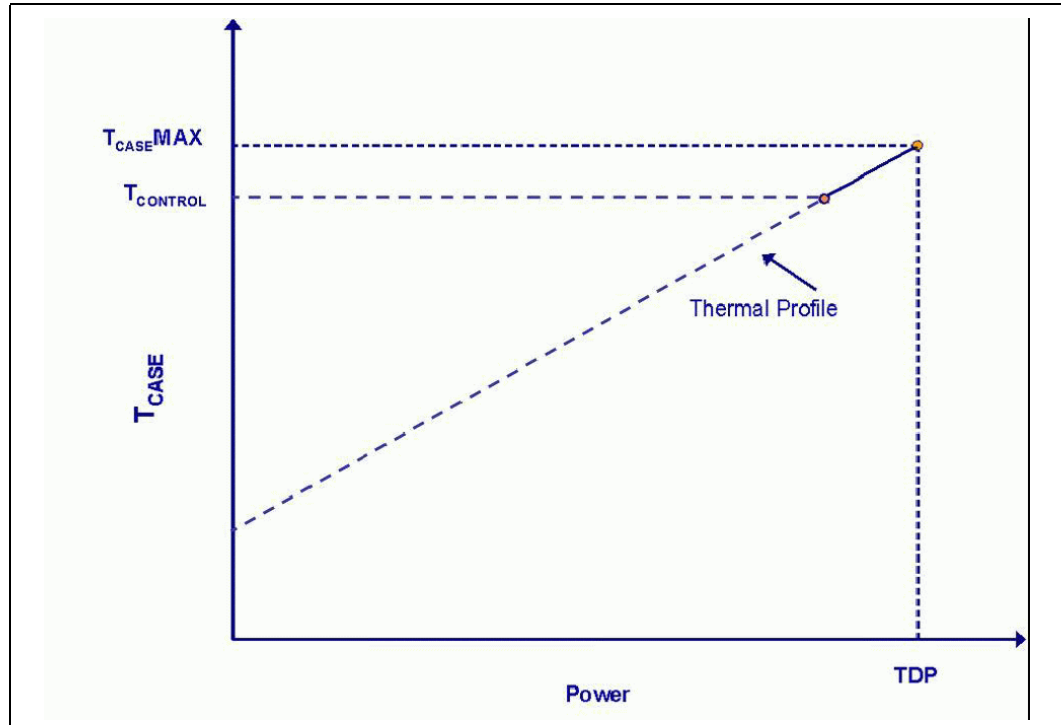

Since $T_{CONTROL}$ is based on a processor DTS temperature value, an equivalent T_{CASE} temperature must be determined to plot the T_{CASE} @ $T_{CONTROL}$ point on the Thermal Profile graph. Location 1 on the Thermal Profile represents a T_{CASE} value corresponding to $P_{PROFILE_MIN}$. Location 2 on the Thermal Profile represents a T_{CASE} value corresponding to $DTS = T_{CONTROL}$. If the DTS temperature is less than $T_{CONTROL}$, then the case temperature is permitted to exceed the Thermal Profile, but the DTS temperature must remain at or below $T_{CONTROL}$. The thermal solution for the processor must be able to keep the processor's T_{CASE} at or below the T_{CASE} values defined by the Thermal Profile between the T_{CASE_MAX} @ $P_{PROFILE_MIN}$ and T_{CASE_MAX} points at the

Refer to [Section 2.3.1](#) for the implementation of the $T_{CONTROL}$ value in support of fan speed control (FSC) design to achieve better acoustic performance.

2.2.7 Performance Targets

The Thermal Profile specifications for this processor are published in the *Quad-Core Intel® Xeon® Processor 5300 Series Electrical, Mechanical and Thermal Specification (EMTS)*. These Thermal Profile specifications are shown as a reference in the subsequent discussions.



Figure 10. Thermal Profile for the Quad-Core Intel® Xeon® Processor L5318

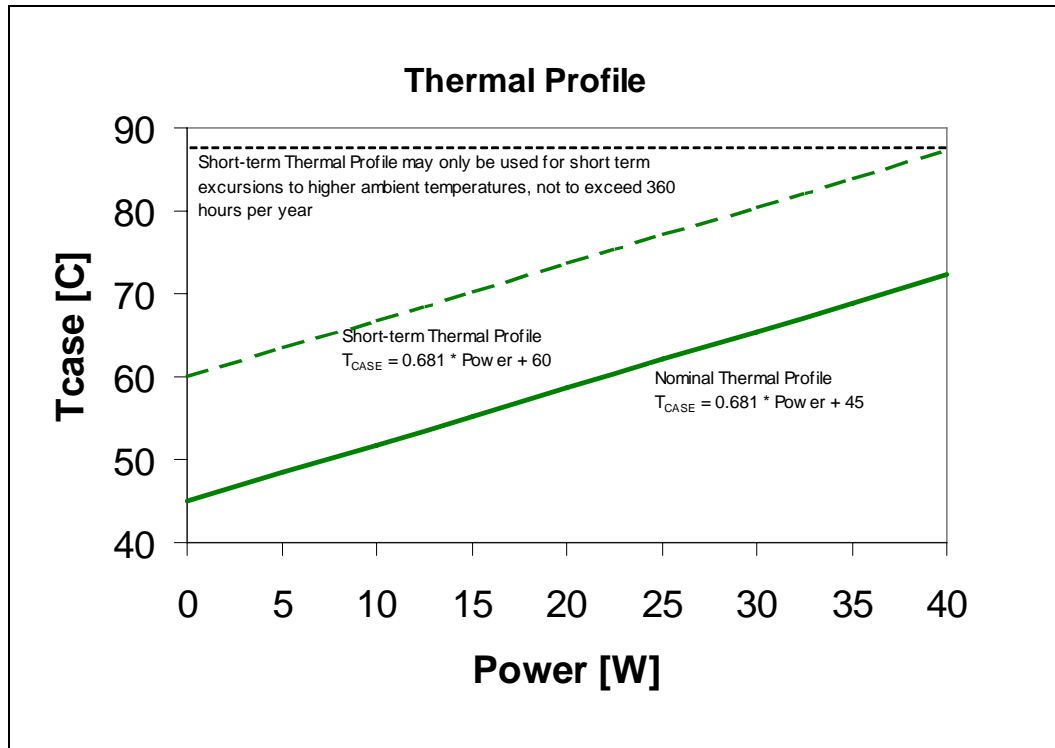

Notes:

1. The thermal specifications shown in this graph are for reference only. Refer to the Quad-Core Intel® Xeon® Processor 5300 Series Electrical, Mechanical and Thermal Specification (EMTS) for the Thermal Profile specifications. In case of conflict, the data information in the EMTS supersedes any data in this figure.
2. The Nominal Thermal Profile must be used for all normal operating conditions, or for products that do not require NEBS Level 3 compliance.
3. The Short-Term Thermal Profile may only be used for short-term excursions to higher ambient operating temperatures, not to exceed 96 hours per instance, 360 hours per year, and a maximum of 15 instances per year, as compliant with NEBS Level 3.
4. Implementation of either thermal profile should result in virtually no TCC activation.
5. Utilization of a thermal solution that exceeds the Short-Term Thermal Profile, or which operates at the Short-Term Thermal Profile for a duration longer than the limits specified in Note 3 above, do not meet the processor's thermal specifications and may result in permanent damage to the processor.

Table 6 describes the thermal performance targets for the Quad-Core Intel® Xeon® processor L5318 cooling solution enabled by Intel.



Table 6. Intel Reference Heatsink Performance Targets for the Quad-Core Intel® Xeon® Processor L5318 Series

Parameter	Maximum	Unit	Notes
Altitude	Sea-level	m	Heatsink designed at 0 meters
Nominal T _{LA}	40	°C	
Short Term T _{LA}	55	°C	
TDP	40	W	
ATCA Reference Solution, Nominal Thermal Profile			
T _{CASE_MAX}	72.2	°C	
Airflow	2.7	CFM	Airflow through the heatsink fins
Ψ _{CA}	0.757	°C/W	Mean + 3σ
ATCA Reference Solution, Short Term Thermal Profile			
T _{CASE_MAX}	87.2	°C	
Airflow	2.7	CFM	Airflow through the heatsink fins
Ψ _{CA}	0.757	°C/W	Mean + 3σ

Note: In case of conflict, the processor EMTS supersedes the information contained in the TMDG.

2.3 Characterizing Cooling Solution Performance Requirements

2.3.1 Fan Speed Control

Fan speed control (FSC) techniques to reduce system level acoustic noise are a common practice in server designs. The fan speed is one of the parameters that determine the amount of airflow provided to the thermal solution. Additionally, airflow is proportional to a thermal solution’s performance, which consequently determines the T_{CASE} of the processor at a given power level. Since the T_{CASE} of a processor is an important parameter in the long-term reliability of a processor, the FSC implemented in a system directly correlates to the processor’s ability to meet the Thermal Profile and hence the long-term reliability requirements. For this purpose, the parameter called T_{CONTROL} as explained in [Section 2.2.6](#), is to be used in FSC designs to ensure that the long-term reliability of the processor is met while keeping the system level acoustic noise down. [Figure 11](#) depicts the relationship between T_{CONTROL} and FSC methodology.

Figure 11. $T_{CONTROL}$ and Fan Speed Control

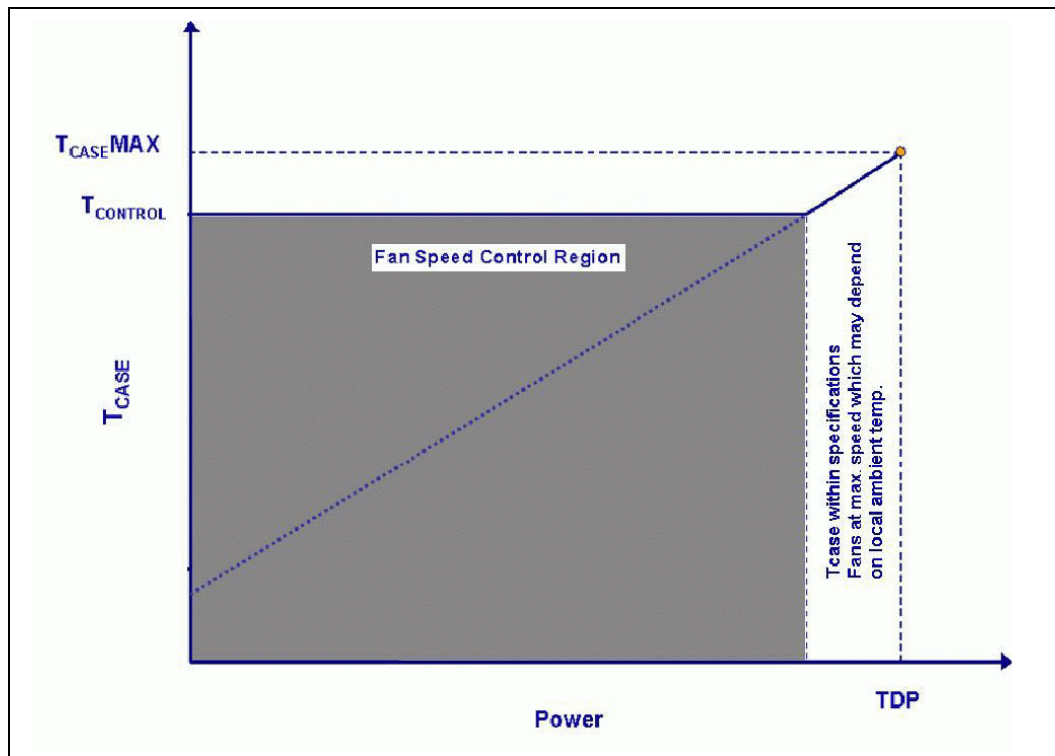

Once the $T_{CONTROL}$ value is determined as explained earlier, the DTS temperature reading from the processor can be compared to this $T_{CONTROL}$ value. A fan speed control scheme can be implemented as described in Table 7 without compromising the long-term reliability of the processor.

Table 7. Fan Speed Control, $T_{CONTROL}$ and DTS Relationship

Condition	FSC Scheme
$DTS \leq T_{CONTROL}$	FSC can adjust fan speed to maintain $DTS \leq T_{CONTROL}$ (low acoustic region).
$DTS > T_{CONTROL}$	FSC should adjust fan speed to keep T_{CASE} at or below the Thermal Profile specification (increased acoustic region).

There are many different ways of implementing fan speed control, including FSC based on processor ambient temperature, FSC based on processor Digital Thermal Sensor (DTS) temperature or a combination of the two. If FSC is based only on the processor ambient temperature, low acoustic targets can be achieved under low ambient temperature conditions. However, the acoustics cannot be optimized based on the behavior of the processor temperature. If FSC is based only on the Digital Thermal Sensor, sustained temperatures above $T_{CONTROL}$ drives fans to maximum RPM. If FSC is based both on ambient and Digital Thermal Sensor, ambient temperature can be used to scale the fan RPM controlled by the Digital Thermal Sensor. This would result in an optimal acoustic performance. Regardless of which scheme is employed, system designers must ensure that the Thermal Profile specification is met when the processor Digital Thermal Sensor temperature exceeds the $T_{CONTROL}$ value for a given processor.



2.3.2 Processor Thermal Characterization Parameter Relationships

The idea of a “thermal characterization parameter”, Ψ (psi), is a convenient way to characterize the performance needed for the thermal solution and to compare thermal solutions in identical conditions (heating source, local ambient conditions). A thermal characterization parameter is convenient in that it is calculated using total package power, whereas actual thermal resistance, θ (theta), is calculated using actual power dissipated between two points. Measuring actual power dissipated into the heatsink is difficult, since some of the power is dissipated via heat transfer into the socket and board. Be aware, however, of the limitations of lumped parameters such as Ψ when it comes to a real design. Heat transfer is a three-dimensional phenomenon that can rarely be accurately and easily modeled by lump values.

The case-to-local ambient thermal characterization parameter value (Ψ_{CA}) is used as a measure of the thermal performance of the overall thermal solution that is attached to the processor package. It is defined by the following equation, and measured in units of $^{\circ}\text{C}/\text{W}$:

Equation 3. $\Psi_{CA} = (T_{CASE} - T_{LA}) / \text{TDP}$

Where:

- Ψ_{CA} = Case-to-local ambient thermal characterization parameter ($^{\circ}\text{C}/\text{W}$).
- T_{CASE} = Processor case temperature ($^{\circ}\text{C}$).
- T_{LA} = Local ambient temperature in chassis at processor ($^{\circ}\text{C}$).
- TDP** = TDP dissipation (W) (assumes all power dissipates through the integrated heat spreader (IHS)).

The case-to-local ambient thermal characterization parameter of the processor, Ψ_{CA} , is comprised of Ψ_{CS} , the TIM thermal characterization parameter, and of Ψ_{SA} , the sink-to-local ambient thermal characterization parameter:

Equation 4. $\Psi_{CA} = \Psi_{CS} + \Psi_{SA}$

Where:

- Ψ_{CS} = Thermal characterization parameter of the TIM ($^{\circ}\text{C}/\text{W}$).
- Ψ_{SA} = Thermal characterization parameter from heatsink-to-local ambient ($^{\circ}\text{C}/\text{W}$).

Ψ_{CS} is strongly dependent on the thermal conductivity and thickness of the TIM between the heatsink and IHS.

Ψ_{SA} is a measure of the thermal characterization parameter from the bottom of the heatsink to the local ambient air. Ψ_{SA} is dependent on the heatsink material, thermal conductivity, and geometry. It is also strongly dependent on the air velocity through the fins of the heatsink.

Figure 12 illustrates the combination of the different thermal characterization parameters.

Figure 12. Processor Thermal Characterization Parameter Relationships

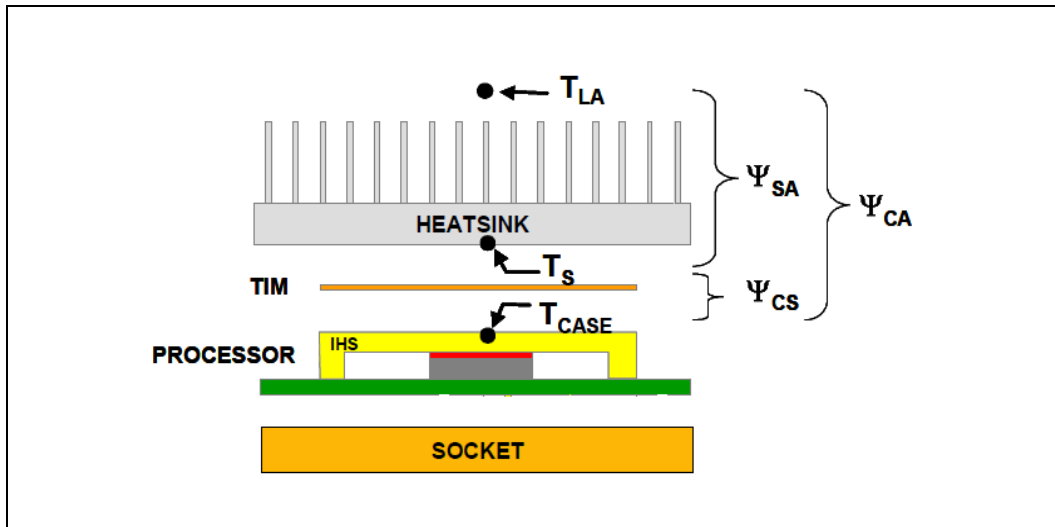

2.3.2.1 Example

The cooling performance, Ψ_{CA} , is then defined using the principle of thermal characterization parameter described above:

- Define a target case temperature T_{CASE_MAX} and corresponding TDP, given in the processor EMTS.
- Define a target local ambient temperature at the processor, T_{LA} .

The following provides an illustration of how one might determine the appropriate performance targets. The example power and temperature numbers used here are not related to any Intel processor thermal specifications, and are for illustrative purposes only.

Assume the EMTS TDP is 85 W and the case temperature specification is 68 °C. Assume as well that the system airflow has been designed such that the local processor ambient temperature is 45 °C. Then the following could be calculated using Equation 3 from above:

Equation 5. $\Psi_{CA} = (T_{CASE} - T_{LA}) / TDP = (68 - 45) / 85 = 0.27 \text{ } ^\circ\text{C/W}$

To determine the required heatsink performance, a heatsink solution provider would need to determine Ψ_{CS} performance for the selected TIM and mechanical load configuration. If the heatsink solution was designed to work with a TIM material performing at $\Psi_{CS} \leq 0.05 \text{ } ^\circ\text{C/W}$, solving for Equation 4 from above, the performance of the heatsink would be:

Equation 6. $\Psi_{SA} = \Psi_{CA} - \Psi_{CS} = 0.27 - 0.05 = 0.22 \text{ } ^\circ\text{C/W}$

If the local processor ambient temperature is assumed to be 40 °C, the same calculation can be carried out to determine the new case-to-ambient thermal resistance:

Equation 7. $\Psi_{CA} = (T_{CASE} - T_{LA}) / TDP = (68 - 40) / 85 = 0.33 \text{ } ^\circ\text{C/W}$

It is evident from the above calculations that, a reduction in the local processor ambient temperature has a significant positive effect on the case-to-ambient thermal resistance requirement.

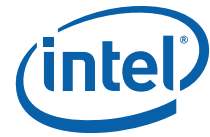

2.3.3 Chassis Thermal Design Considerations

2.3.3.1 Chassis Thermal Design Capabilities and Improvements

One of the critical parameters in thermal design is the local ambient temperature assumption of the processor. Keeping the external chassis temperature fixed, internal chassis temperature rise is the only component that can affect the processor local ambient temperature. Every degree gained at the local ambient temperature directly translates into a degree relief in the processor case temperature.

Given the thermal targets for the processor, it is extremely important to optimize the chassis design to minimize the air temperature rise upstream to the processor (T_{rise}), hence minimizing the processor local ambient temperature. Please refer to *T_{RISE} Reduction Guidelines for Rack Servers and Workstations* for more details.

The heat generated by components within the chassis must be removed to provide an adequate operating environment for both the processor and other system components. Moving air through the chassis brings in air from the external ambient environment and transports the heat generated by the processor and other system components out of the system. The number, size and relative position of fans, vents and other heat generating components determine the chassis thermal performance, and the resulting ambient temperature around the processor. The size and type (passive or active) of the thermal solution and the amount of system airflow can be traded off against each other to meet specific system design constraints. Additional constraints are board layout, spacing, component placement, and structural considerations that limit the thermal solution size.

In addition to passive heatsinks, fan heatsinks and system fans, other solutions exist for cooling integrated circuit devices. For example, ducted blowers, heat pipes and liquid cooling are all capable of dissipating additional heat. Due to their varying attributes, each of these solutions may be appropriate for a particular system implementation.

To develop a reliable, cost-effective thermal solution, thermal characterization and simulation should be carried out at the entire system level, accounting for the thermal requirements of each component. In addition, acoustic noise constraints may limit the size, number, placement, and types of fans that can be used in a particular design.

2.4 Thermal/Mechanical Reference Design Considerations

2.4.1 Heatsink Solutions

2.4.1.1 Heatsink Design Considerations

To remove the heat from the processor, three basic parameters should be considered:

- **The area of the surface on which the heat transfer takes place** - Without any enhancements, this is the surface of the processor package IHS. One method used to improve thermal performance is by attaching a heatsink to the IHS. A heatsink can increase the effective heat transfer surface area by conducting heat out of the IHS and into the surrounding air through fins attached to the heatsink base.
- **The conduction path from the heat source to the heatsink fins** - Providing a direct conduction path from the heat source to the heatsink fins and selecting materials with higher thermal conductivity typically improves heatsink performance. The length, thickness, and conductivity of the conduction path from the heat source to the fins directly impact the thermal performance of the heatsink. In particular, the quality of the contact between the package IHS and the heatsink base has a higher impact on the overall thermal solution performance as processor cooling requirements become strict. Thermal interface material (TIM) is used to fill



in the gap between the IHS and the bottom surface of the heatsink, and thereby improves the overall performance of the thermal stackup (IHS-TIM-Heatsink). With extremely poor heatsink interface flatness or roughness, TIM may not adequately fill the gap. The TIM thermal performance depends on its thermal conductivity as well as the pressure load applied to it. Refer to [Section 2.4.2](#) for further information on the TIM between the IHS and the heatsink base.

- **The heat transfer conditions on the surface on which heat transfer takes place** - Convective heat transfer occurs between the airflow and the surface exposed to the flow. It is characterized by the local ambient temperature of the air, T_{LA} , and the local air velocity over the surface. The higher the air velocity over the surface, the resulting cooling is more efficient. The nature of the airflow can also enhance heat transfer via convection. Turbulent flow can provide improvement over laminar flow. In the case of a heatsink, the surface exposed to the flow includes the fin faces and the heatsink base.

An active heatsink typically incorporates a fan that helps manage the airflow through the heatsink.

Passive heatsink solutions require in-depth knowledge of the airflow in the chassis. Typically, passive heatsinks see slower air speed. Therefore, these heatsinks are typically larger (and heavier) than active heatsinks due to the increase in fin surface required to meet a required performance. As the heatsink fin density (the number of fins in a given cross-section) increases, the resistance to the airflow increases: it is more likely that the air will travel around the heatsink instead of through it, unless air bypass is carefully managed. Using air-ducting techniques to manage bypass area is an effective method for maximizing airflow through the heatsink fins.

2.4.2 Thermal Interface Material

TIM application between the processor IHS and the heatsink base is generally required to improve thermal conduction from the IHS to the heatsink. Many thermal interface materials can be pre-applied to the heatsink base prior to shipment from the heatsink supplier and allow direct heatsink attach, without the need for a separate TIM dispense or attach process in the final assembly factory.

All thermal interface materials should be sized and positioned on the heatsink base in a way that ensures the entire processor IHS area is covered. It is important to compensate for heatsink-to-processor attach positional alignment when selecting the proper TIM size.

When pre-applied material is used, it is recommended to have a protective application tape over it. This tape must be removed prior to heatsink installation.

The TIM performance is susceptible to degradation (i.e., grease breakdown) during the useful life of the processor due to the temperature cycling phenomena. For this reason, the measured T_{CASE} value of a given processor can decrease over time depending on the type of TIM material.

2.4.3 Summary

In summary, considerations in heatsink design include:

- The local ambient temperature T_{LA} at the heatsink, airflow (CFM), the power being dissipated by the processor, and the corresponding maximum T_{CASE} . These parameters are usually combined in a single lump cooling performance parameter, Ψ_{CA} (case to air thermal characterization parameter). More information on the definition and the use of Ψ_{CA} is given in [Section 2.4](#) and [Section 2.3.2](#).
- Heatsink interface (to IHS) surface characteristics, including flatness and roughness.

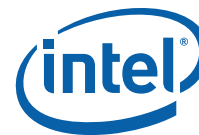

- The performance of the TIM used between the heatsink and the IHS.
- Surface area of the heatsink.
- Heatsink material and technology.
- Development of airflow entering and within the heatsink area.
- Physical volumetric constraints placed by the system.
- Integrated package/socket stackup height information is provided in the *LGA771 Socket Mechanical Design Guide*.



2.4.4 Assembly Overview of the Intel Reference Thermal Mechanical Design

The reference design heatsinks that meet the Quad-Core Intel® Xeon® processor 5300 series thermal performance targets are called the Common Enabling Kit (CEK) heatsinks, and are available in AdvancedTCA, 1U, 2U, & 2U+ form factors. Each CEK consists of the following components:

- Heatsink (with captive standoff and screws)
- Thermal Interface Material (TIM)
- CEK Spring

2.4.4.1 Geometric Envelope

The baseboard keepout zones on the primary and secondary sides and height restrictions under the enabling component region are shown in detail in [Appendix A](#). The overall volumetric keep in zone encapsulates the processor, socket, and the entire thermal/mechanical enabling solution.

2.4.4.2 Assembly Drawing

Figure 13. Exploded View of CEK Thermal Solution Components

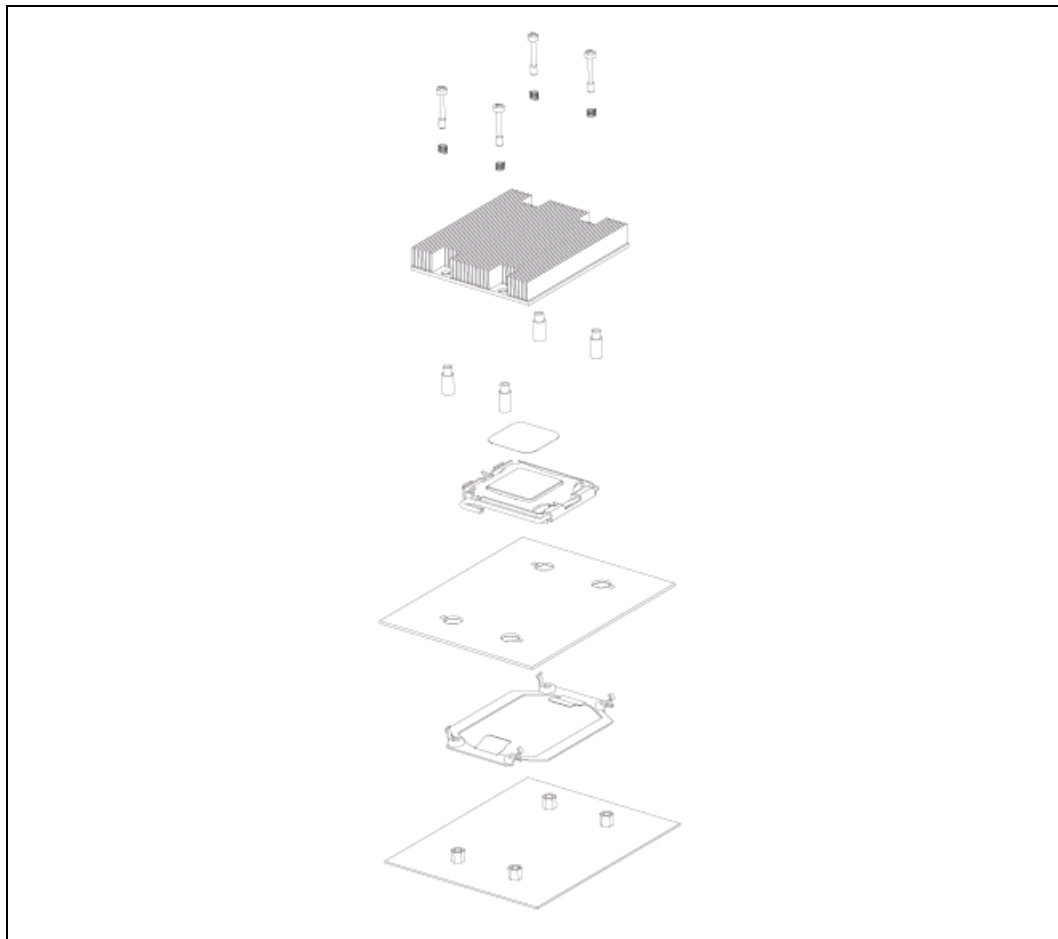

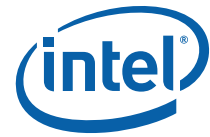

The CEK reference thermal solution is designed to extend air-cooling capability through the use of larger heatsinks with minimal airflow blockage and bypass. CEK retention solution can allow the use of much heavier heatsink masses compared to the legacy limits by using a load path directly attached to the chassis pan. The CEK spring on the secondary side of the baseboard provides the necessary compressive load for the thermal interface material. The baseboard is intended to be isolated such that the dynamic loads from the heatsink are transferred to the chassis pan via the stiff screws and standoffs. This reduces the risk of package pullout and solder-joint failures.

Using the CEK reference thermal solution, Intel recommends that the maximum outside diameter dimension of the chassis pan standoffs, regardless of shape, that interfaces with the CEK spring on the secondary side of the baseboard and captive screws on the primary side of the baseboard to attach the heatsink to the chassis pan should be no larger than 7.112 mm [0.28 in.]. For example, circular standoffs should be no larger than 7.112 mm [0.28 in.] point-to-point.

The baseboard mounting holes for the CEK solution are at the same location as the hole locations used for previous Intel® Xeon® processor thermal solution. However, CEK assembly requires 10.16 mm [0.400 in.] large diameter holes to compensate for the CEK spring embosses.

The CEK solution is designed and optimized for a baseboard thickness range of 1.57 – 2.31 mm [0.062-0.093 in]. While the same CEK spring can be used for this board thickness range, the heatsink standoff height is different for a 1.57 mm [0.062 in] thick board than it is for a 2.31 mm [0.093 in] thick board. In the heatsink assembly, the standoff protrusion from the base of the heatsink needs to be 0.6 mm [0.024 in] longer for a 2.31 mm [0.093 in] thick board, compared to a 1.57 mm [0.062 in] thick board. If this solution is intended to be used on baseboards that fall outside of this range, then some aspects of the design, including but not limited to the CEK spring design and the standoff heights, may need to change. Therefore, system designers need to evaluate the thermal performance and mechanical behavior of the CEK design on baseboards with different thicknesses.

Refer to [Appendix A](#) for drawings of the heatsinks and CEK spring. The screws and standoffs are standard components that are made captive to the heatsink for ease of handling and assembly.

Contact your Intel field sales representative for an electronic version of mechanical and thermal models of the CEK (Pro/Engineer*, IGES and Icepak*, Flotherm* formats). Pro/Engineer, Icepak and Flotherm models are available on Intel Business Link (IBL).

Note: Intel reserves the right to make changes and modifications to the design as necessary.

Note: The thermal mechanical reference design for the Quad-Core Intel® Xeon® processor 5300 series was verified according to the Intel validation criteria given in [Appendix D](#). Any thermal mechanical design using some of the reference components in combination with any other thermal mechanical solution needs to be fully validated according to the customer criteria. Also, if customer thermal mechanical validation criteria differ from the Intel criteria, the reference solution should be validated against the customer criteria.

2.4.4.3 Structural Considerations of Common Enabling Kit (CEK)

As Intel explores methods of keeping thermal solutions within the air-cooling space, the mass of the thermal solutions is increasing. Due to the flexible nature (and associated large deformation) of baseboard-only attachments, Intel reference solutions, such as CEK, are now commonly using direct chassis attach (DCA) as the mechanical retention design. The mass of the new thermal solutions is large enough to require consideration for structural support and stiffening on the chassis. Intel has published a best know

method (BKM) document that provides specific structural guidance for designing DCA thermal solutions. The document is titled *Chassis Strength and Stiffness Measurement and Improvement Guidelines for Direct Chassis Attach Solutions*.

2.4.5 AdvancedTCA Thermal Solution Performance

The reference thermal solution compatible with the AdvancedTCA form factor is designed to meet the thermal profile with a minimum volumetric airflow rate through the AdvancedTCA slot of 30CFM. The reference heat sink should be made from copper to achieve the necessary thermal performance. Based on the nominal and short-term boundary conditions stated (ambient temperature = 40C nominal and 55C short term), the heat sink will meet the thermal performance needed to cool the 40W processor in the AdvancedTCA form factor

Figure 14 shows the performance of the AdvancedTCA passive heatsink on the Quad-Core Intel® Xeon® processor L5318. This figure show the thermal performance of the heatsink versus the airflow provided. The best-fit equation for this curve is also provided to make it easier for users to determine the desired value without any error associated with reading the graph.

Figure 14. AdvancedTCA CEK Heatsink Thermal Performance

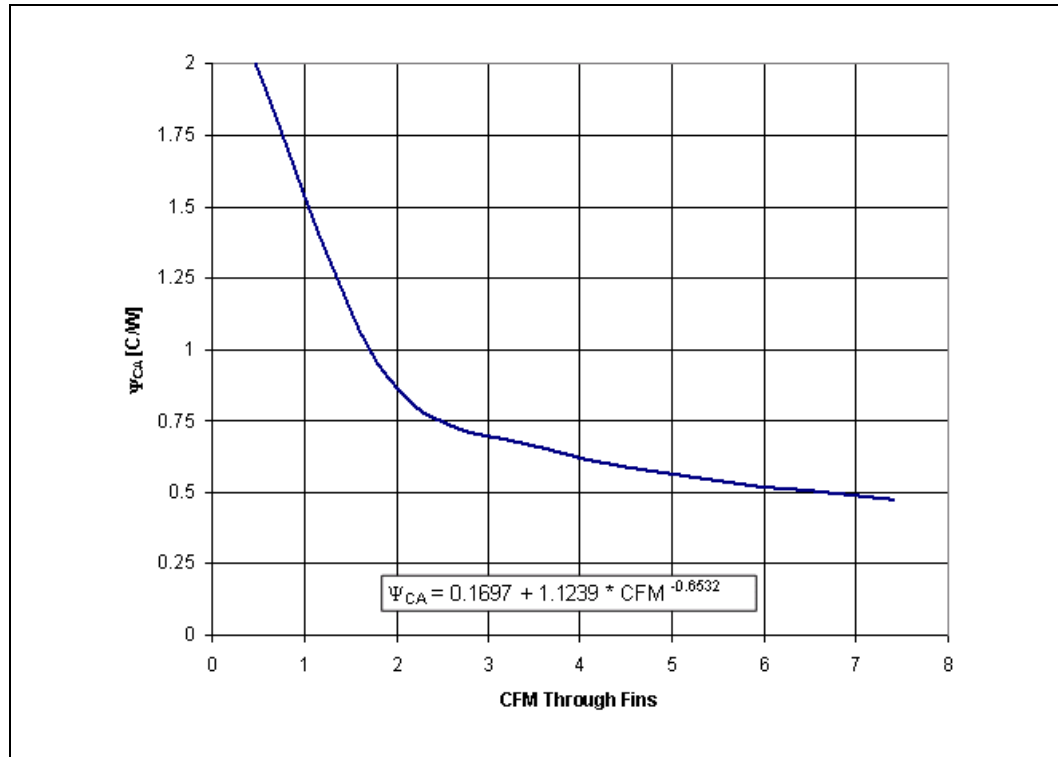

If other custom heatsinks are intended for use with the Quad-Core Intel® Xeon® processor 5300 series, they must support the following interface control requirements to be compatible with the reference mechanical components:

Any custom thermal solution design must meet the loading specification as documented within this document, and should refer to the *Quad-Core Intel® Xeon® Processor 5300 Series Electrical, Mechanical and Thermal Specification (EMTS)* and *LGA771 Socket Mechanical Design Guide* and for specific details on package/socket loading specifications.

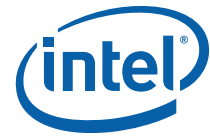

2.4.6 Components Overview

2.4.6.1 Heatsink with Captive Screws and Standoffs

The CEK reference heatsink uses snapped-fin technology for its design. It consists of a copper base and copper fins with Honeywell* PCM45F or Shin-Etsu* G751 thermal grease as the TIM. The mounting screws and standoffs are also made captive to the heatsink base for ease of handling and assembly as shown in [Figure 15](#) and for the AdvancedTCA* heatsink.

Figure 15. Isometric View of the ATCA Heatsink

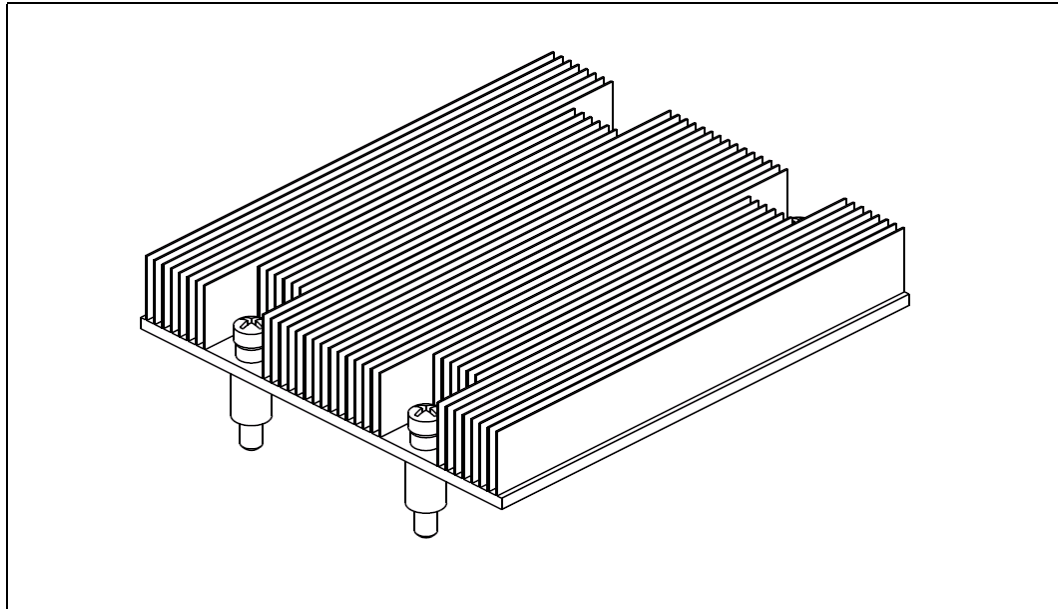

Note: Refer to [Appendix A](#) for more detailed mechanical drawings of the heatsink.

The function of the standoffs is to provide a bridge between the chassis and the heatsink for attaching and load carrying. When assembled, the heatsink is rigid against the top of the standoff, and the standoff is rigid to a chassis standoff with the CEK spring firmly sandwiched between the two. In dynamic loading situations the standoff carries much of the heatsink load, especially in lateral conditions, when compared to the amount of load transmitted to the processor package. As such, it is comprised of steel. The distance from the bottom of the heatsink to the bottom of the standoff is 8.79 mm [0.346 in.] for a board thickness of 1.57 mm [0.062 in]. The standoff will need to be modified for use in applications with a different board thickness, as defined in [Section 2.4.4.2](#).

The function of the screw is to provide a rigid attach method to sandwich the entire CEK assembly together, activating the CEK spring under the baseboard, and thus providing the TIM preload. A screw is an inexpensive, low profile solution that does not negatively impact the thermal performance of the heatsink due to air blockage. Any fastener (i.e. head configuration) can be used as long as it is of steel construction; the head does not interfere with the heatsink fins, and is of the correct length of 20.64 mm [0.8125 in.].

Although the CEK heatsink fits into the legacy volumetric keep-in, it has a larger footprint due to the elimination of retention mechanism and clips used in the older enabled thermal/mechanical components. This allows the heatsink to grow its base and fin dimensions, further improving the thermal performance. A drawback of this enlarged size and use of copper for both the base and fins is the increased weight of the heatsink. The retention scheme employed by CEK is designed to support heavy

heatsinks (approximately up to 1000 grams) in cases of shock, vibration and installation as explained in [Appendix D](#). Some of the thermal and mechanical characteristics of the CEK heatsinks are shown in [Table 8](#).

Table 8. CEK Heatsink Thermal Mechanical Characteristics

Size	Height	Weight	Target Airflow Through Fins	Mean Ψ_{ca}	Standard Deviation Ψ_{ca}
	(mm) [in.]	(kg) [lbs]	(m ³ /hr) [CFM]	(°C/W)	(°C/W)
ATCA	13.36 [0.53]	0.24 [0.53]	4.59 [2.7]	0.757	0.004

2.4.6.2 CEK Spring

The CEK spring, which is attached on the secondary side of the baseboard, is made from 0.80 mm [0.0315 in.] thick 301 stainless steel half hard. Any future versions of the spring will be made from a similar material. The CEK spring has four embosses which, when assembled, rest on the top of the chassis standoffs. The CEK spring is located between the chassis standoffs and the heatsink standoffs. The purpose of the CEK spring is to provide compressive preload at the TIM interface when the baseboard is pushed down upon it. This spring does not function as a clip of any kind. The two tabs on the spring are used to provide the necessary compressive preload for the TIM when the whole solution is assembled. The tabs make contact on the secondary side of the baseboard. In order to avoid damage to the contact locations on the baseboard, the tabs are insulated with a 0.127 mm [0.005 in.] thick Kapton* tape (or equivalent). [Figure 16](#) shows an isometric view of the CEK spring design.

The CEK reference solution is designed to apply a compressive load of up to 133N [30 lbf] on the TIM to improve the thermal performance.

Figure 16. CEK Spring Isometric View

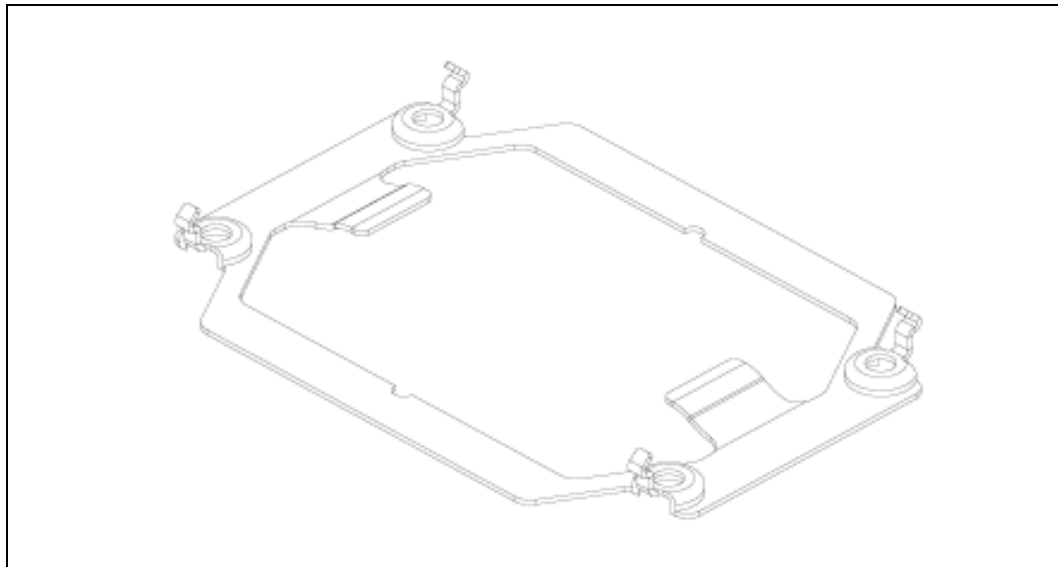
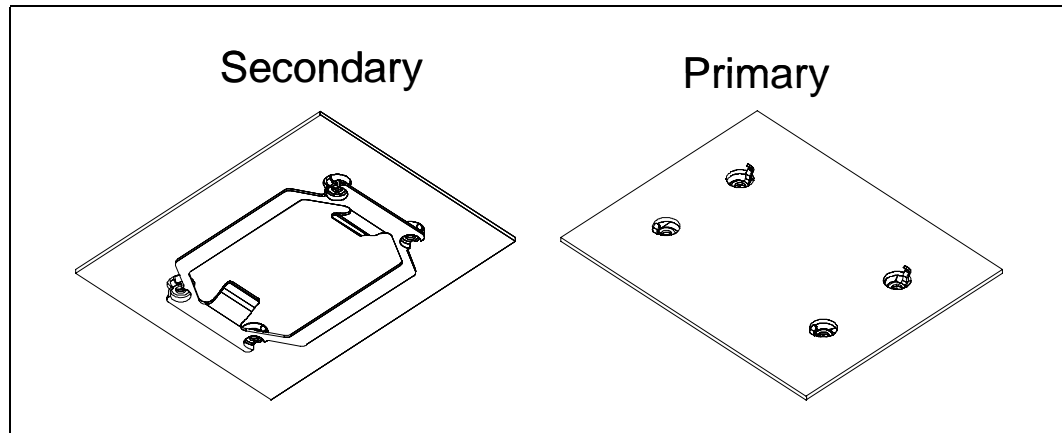



Figure 17. Isometric View of CEK Spring Attachment to the Base Board



Please refer to [Appendix A](#) for more detailed mechanical drawings of the CEK spring. Also, the baseboard keepout requirements shown in [Appendix A](#) must be met to use this CEK spring design.



Appendix A Mechanical Drawings

The mechanical drawings included in this appendix refer to the thermal mechanical enabling components for the Dual-Core Intel Xeon Processor 5300 Series.

Note: Intel reserves the right to make changes and modifications to the design as necessary.

Table 9. Mechanical Drawing List

Drawing Description	Figure Number
"AdvancedTCA* CEK Heatsink (Sheet 1 of 3)"	Figure 18
"AdvancedTCA* CEK Heatsink (Sheet 2 of 3)"	Figure 19
"AdvancedTCA* CEK Heatsink (Sheet 3 of 3)"	Figure 20
"CEK Spring (Sheet 1 of 3)"	Figure 21
"CEK Spring (Sheet 2 of 3)"	Figure 22
"CEK Spring (Sheet 3 of 3)"	Figure 23
"Baseboard Keepout Footprint Definition and Height Restrictions for Enabling Components (Sheet 1 of 5)"	Figure 24
"Baseboard Keepout Footprint Definition and Height Restrictions for Enabling Components (Sheet 2 of 5)"	Figure 25
"Baseboard Keepout Footprint Definition and Height Restrictions for Enabling Components (Sheet 3 of 5)"	Figure 26
"Baseboard Keepout Footprint Definition and Height Restrictions for Enabling Components (Sheet 4 of 5)"	Figure 27
"Baseboard Keepout Footprint Definition and Height Restrictions for Enabling Components (Sheet 5 of 5)"	Figure 28



Figure 18. AdvancedTCA* CEK Heatsink (Sheet 1 of 3)

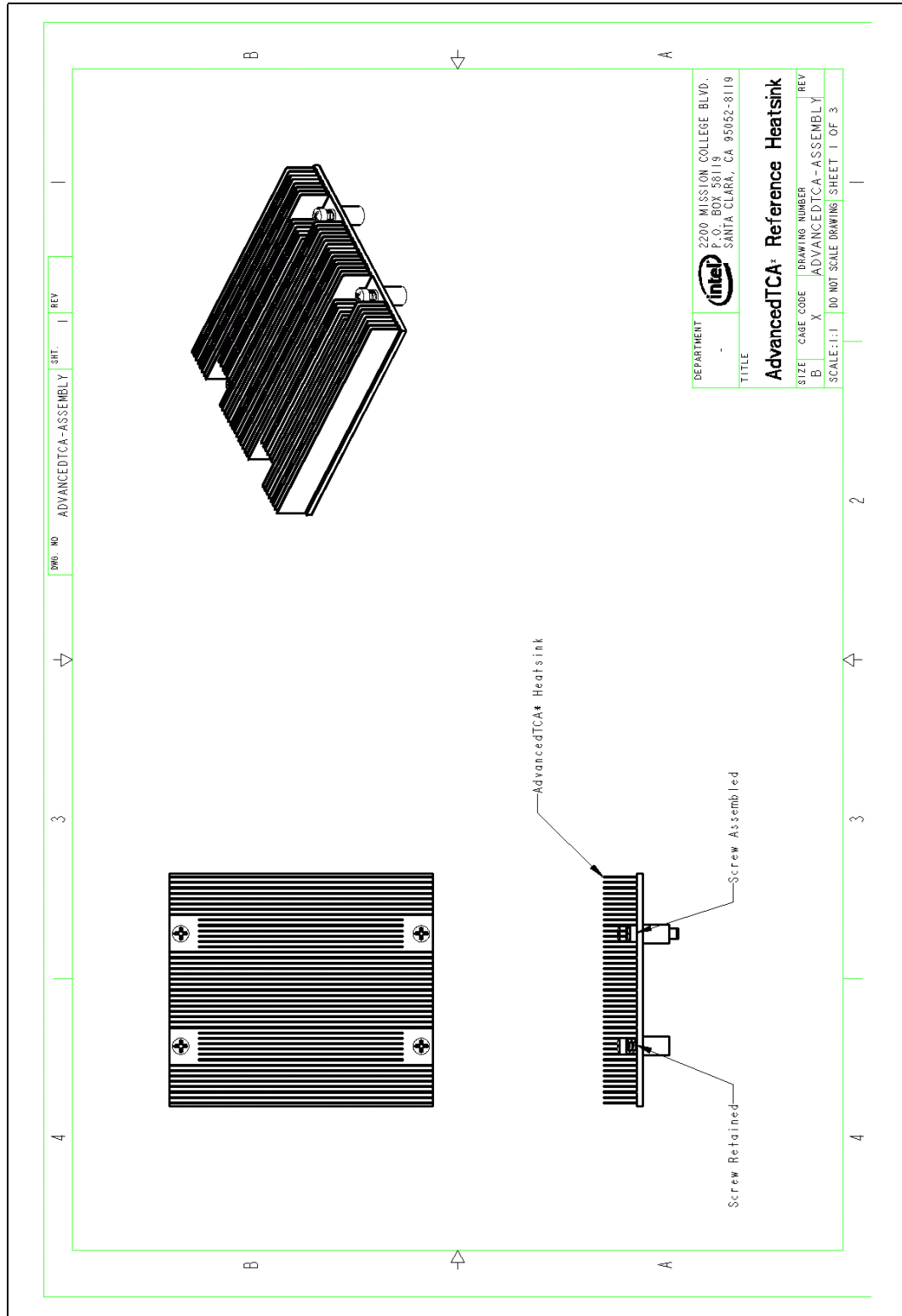

Figure 19. AdvancedTCA* CEK Heatsink (Sheet 2 of 3)

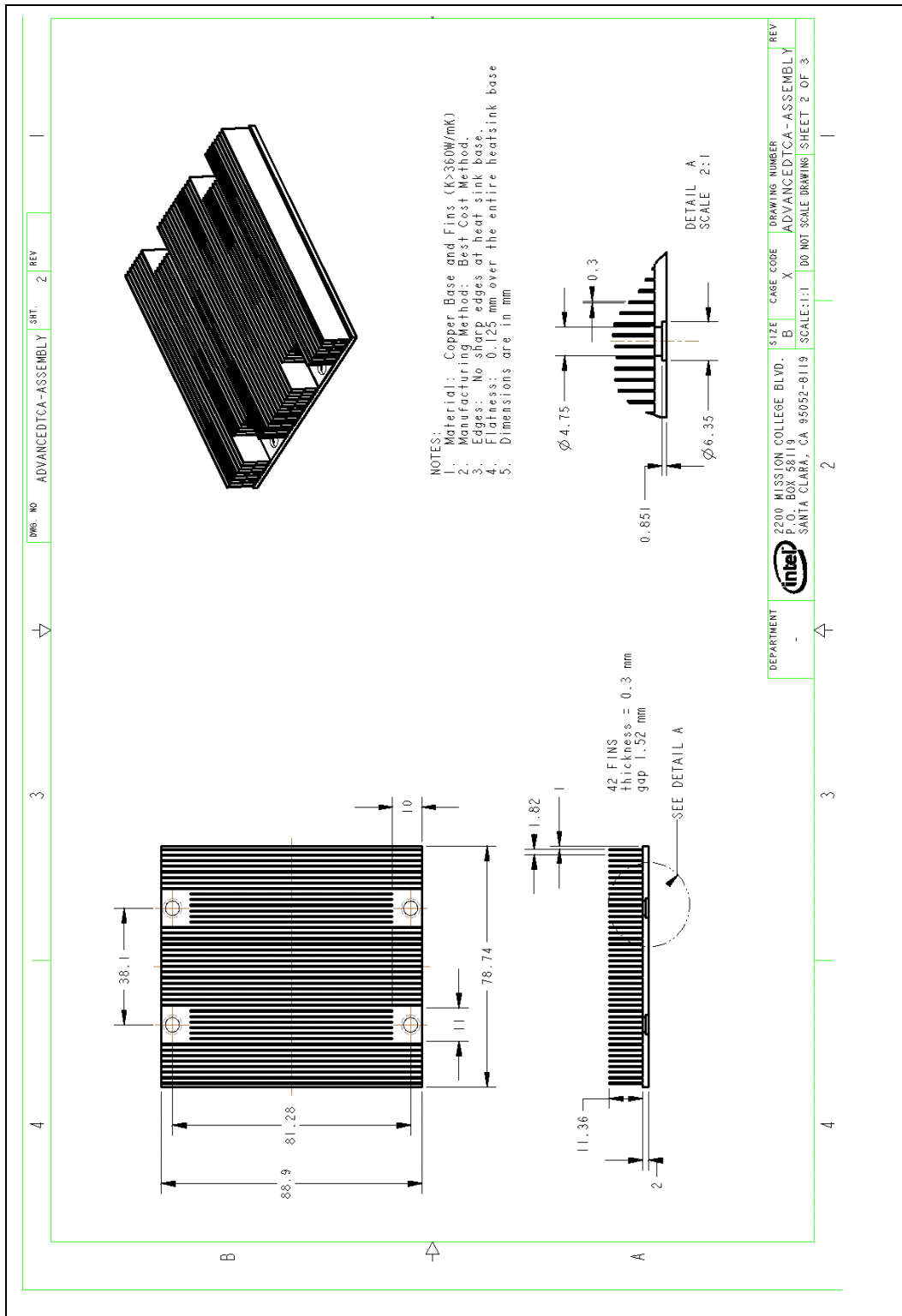



Figure 20. AdvancedTCA* CEK Heatsink (Sheet 3 of 3)

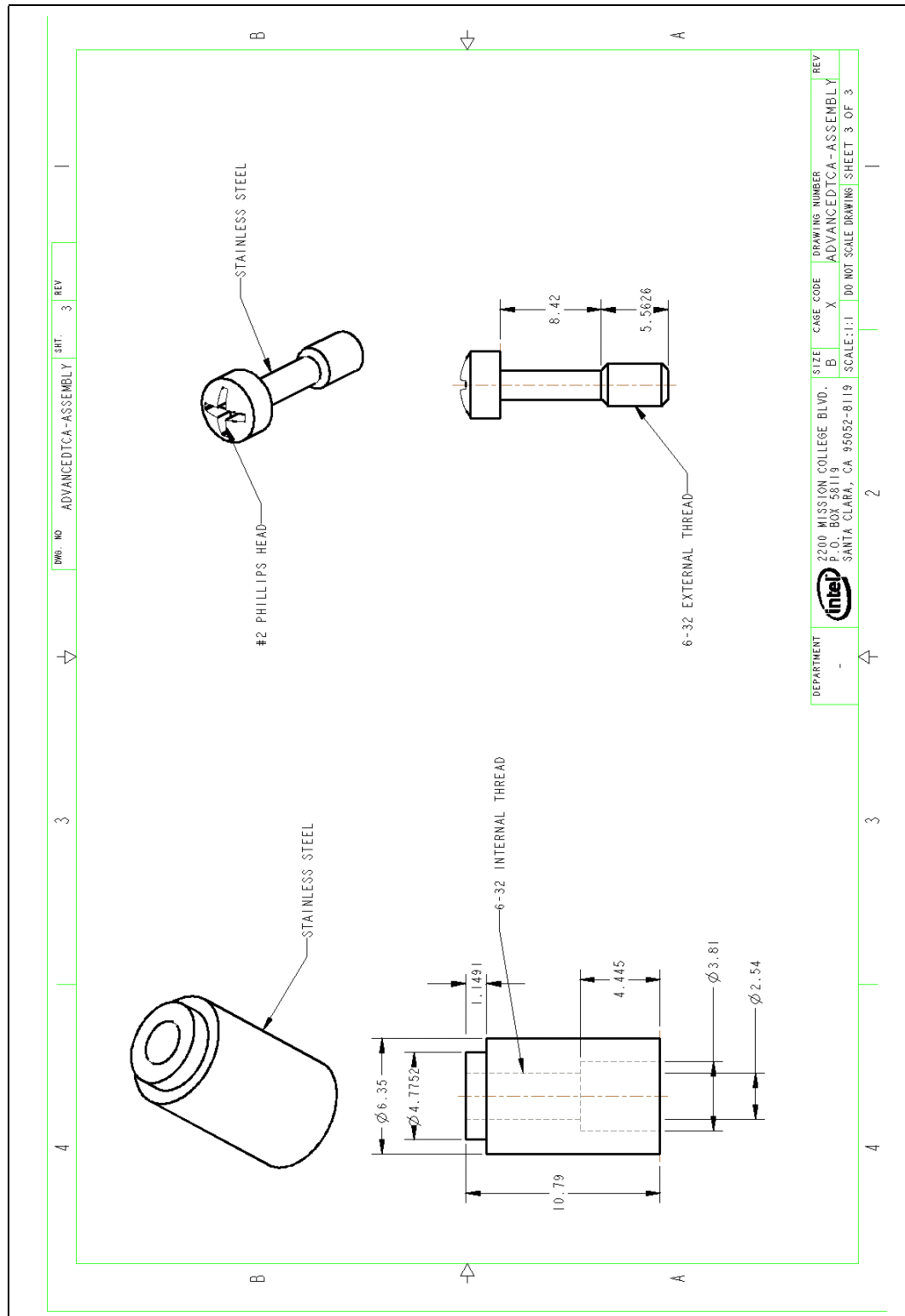

Figure 21. CEK Spring (Sheet 1 of 3)

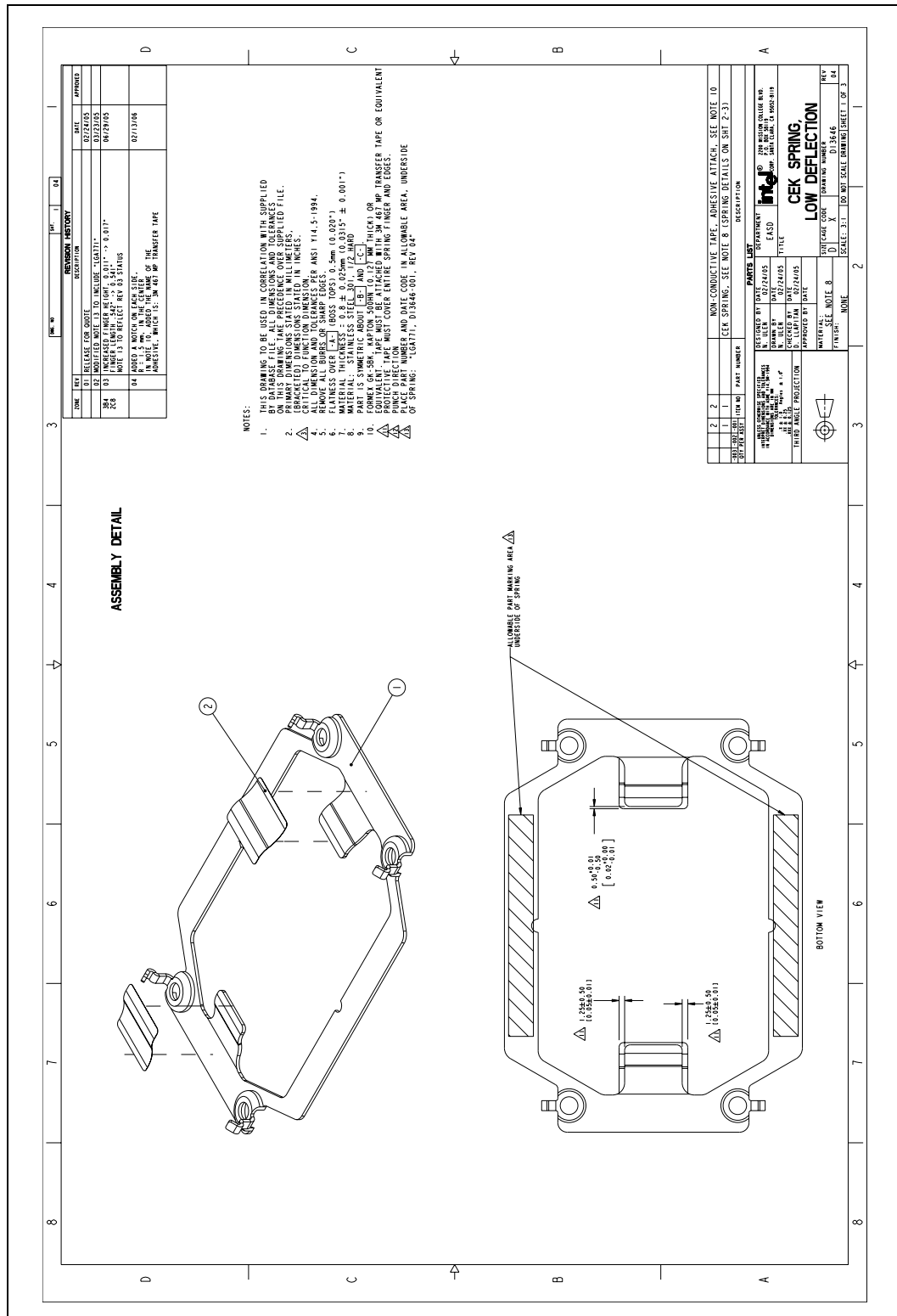
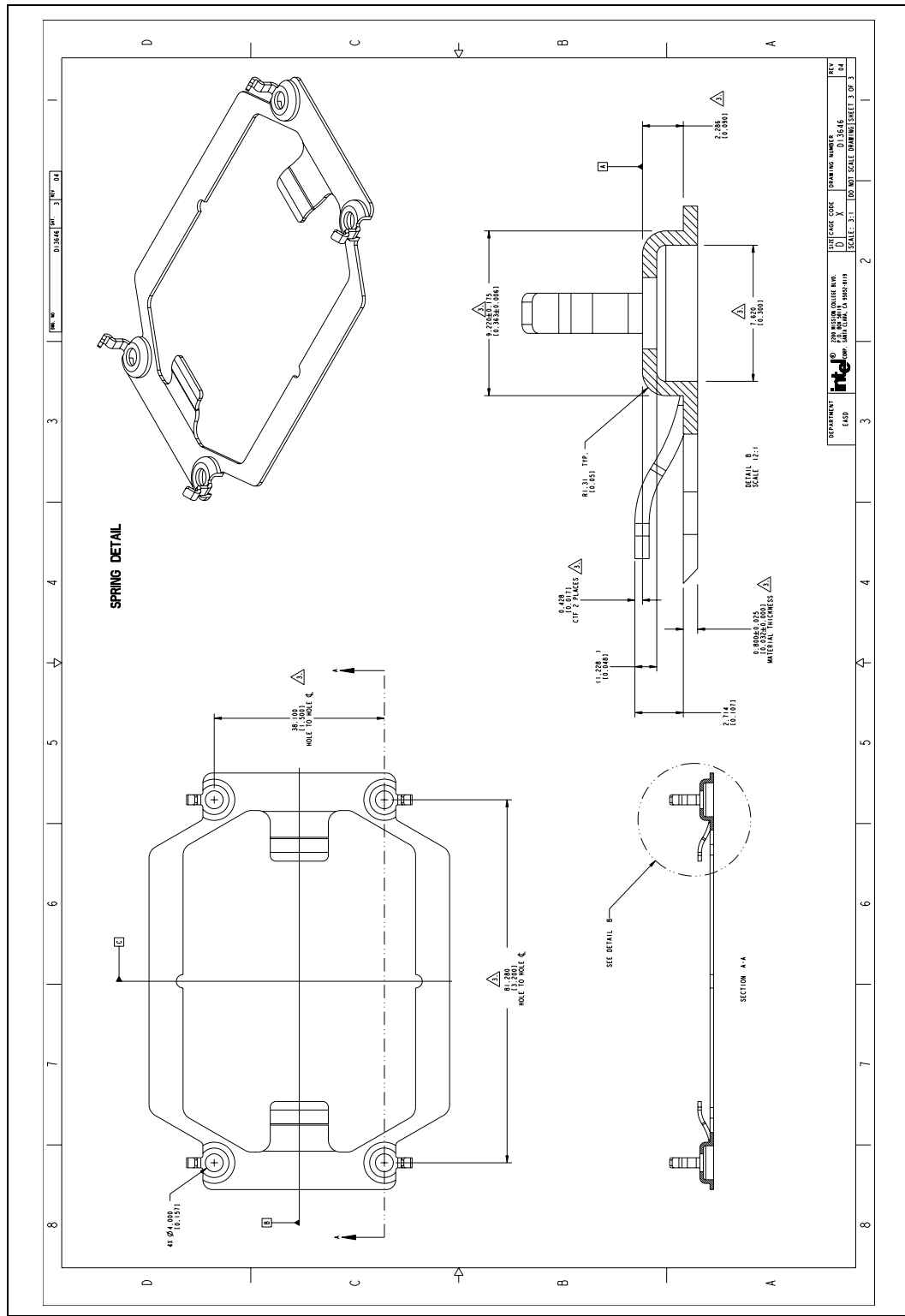

Figure 23. CEK Spring (Sheet 3 of 3)



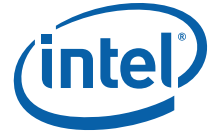
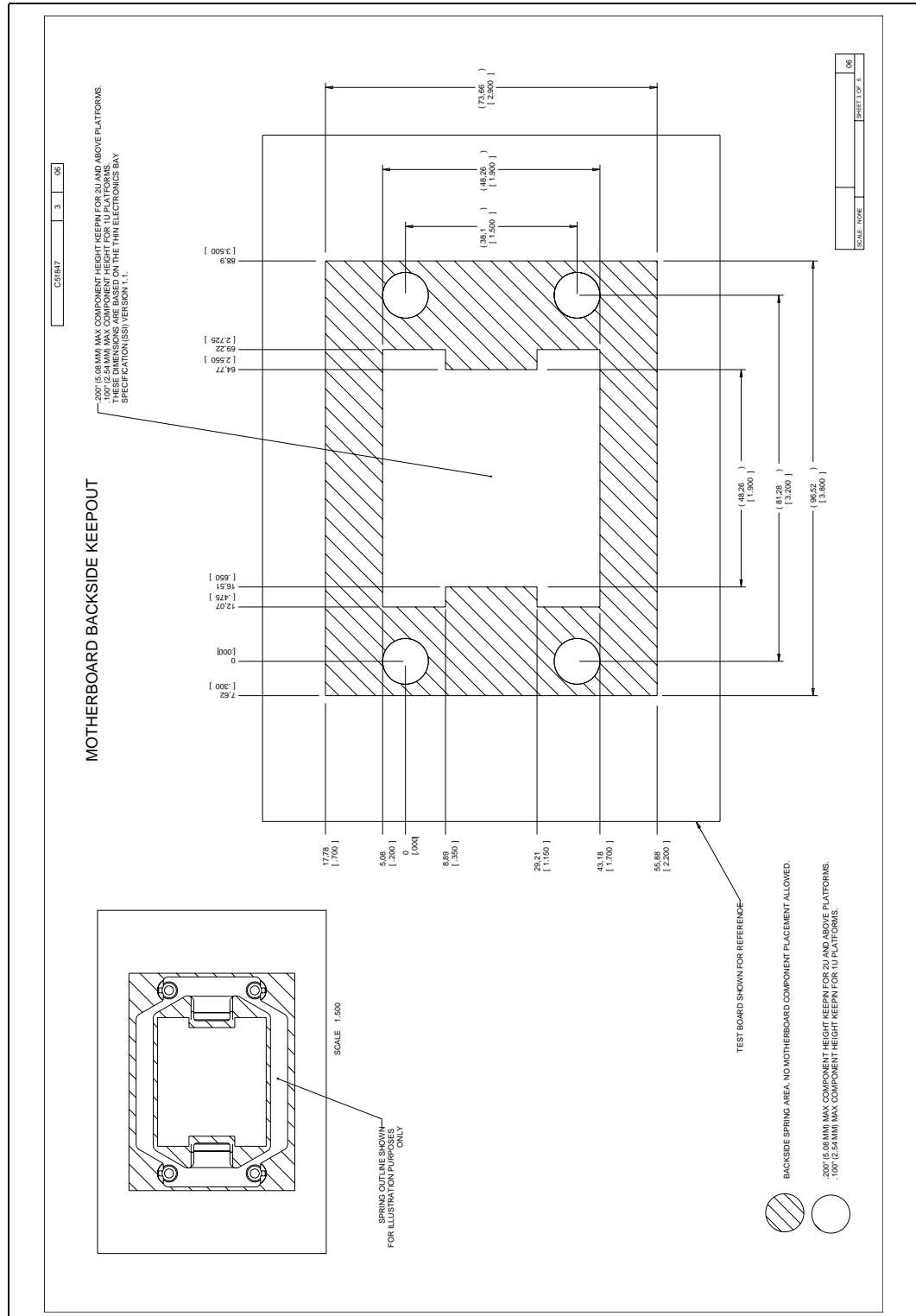

Figure 26. Baseboard Keepout Footprint Definition and Height Restrictions for Enabling Components (Sheet 3 of 5)



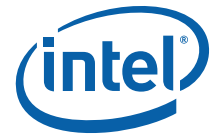
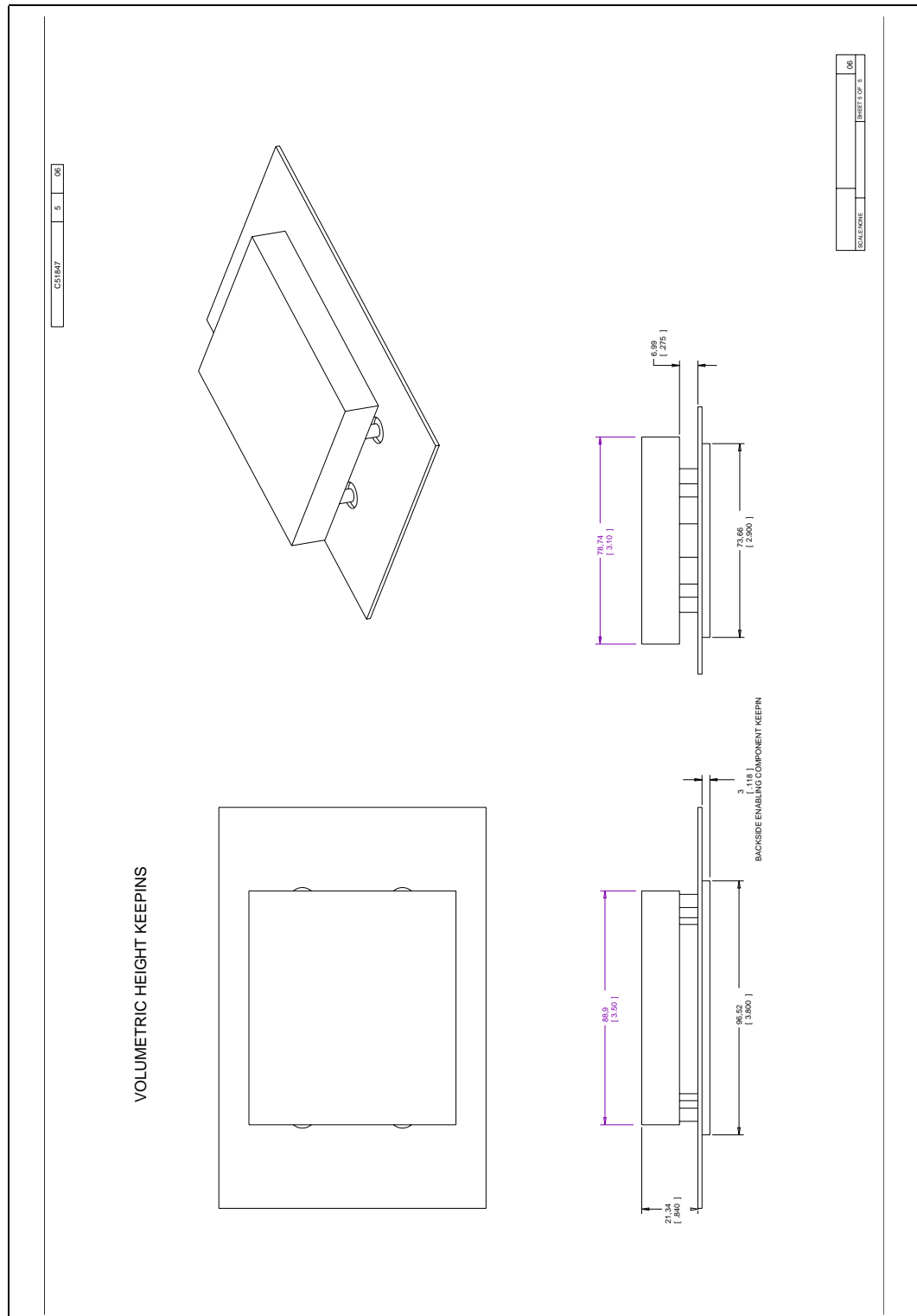

Figure 28. Baseboard Keepout Footprint Definition and Height Restrictions for Enabling Components (Sheet 5 of 5)





Appendix B Heatsink Clip Load Methodology

B.1 Overview

This section describes a procedure for measuring the load applied by the heatsink/clip/fastener assembly on a processor package.

This procedure is recommended to verify the preload is within the design target range for a design, and in different situations. For example:

- Heatsink preload for the LGA771 socket.
- Quantify preload degradation under bake conditions.

Note: This document reflects the current metrology used by Intel. Intel is continuously exploring new ways to improve metrology. Updates will be provided later as this document is revised as appropriate.

B.2 Test Preparation

B.2.1 Heatsink Preparation

Three load cells are assembled into the base of the heatsink under test, in the area interfacing with the processor Integrated Heat Spreader (IHS), using load cells equivalent to those listed in [Section B.2.2](#).

To install the load cells, machine a pocket in the heatsink base, as shown in [Figure 29](#) and [Figure 30](#). The load cells should be distributed evenly, as close as possible to the pocket walls. Apply wax around the circumference of each load cell and the surface of the pocket around each cell to maintain the load cells in place during the heatsink installation on the processor and motherboard.

The depth of the pocket depends on the height of the load cell used for the test. It is necessary that the load cells protrude out of the heatsink base. However, this protrusion should be kept minimal, as it will create an additional load offset since the heatsink base is artificially raised. The measurement load offset depends on the whole assembly stiffness (i.e. motherboard, clip, fastener, etc.). For example, the Quad-Core Intel® Xeon® processor 5300 series CEK Reference Heatsink Design clip and fasteners assembly have a stiffness of around 160 N/mm [915 lb/in]. If the resulting protrusion is 0.038 mm [0.0015"], then an extra load of 6.08 N [1.37 lb] will be created, and will need to be subtracted from the measured load. [Figure 31](#) shows an example using the Quad-Core Intel® Xeon® processor 5300 series CEK Reference Heatsink designed for the Quad-Core Intel® Xeon® processor 5300 series in the 771-land LGA package.

Note: When optimizing the heatsink pocket depth, the variation of the load cell height should also be taken into account to make sure that all load cells protrude equally from the heatsink base. It may be useful to screen the load cells prior to installation to minimize variation.



Alternate Heatsink Sample Preparation

As just mentioned, making sure that the load cells have minimum protrusion out of the heatsink base is paramount to meaningful results. An alternate method to make sure that the test setup will measure loads representative of the non-modified design is:

- Machine the pocket in the heatsink base to a depth such that the tips of the load cells are just flush with the heatsink base.
- Then machine back the heatsink base by around 0.25 mm [0.01"], so that the load cell tips protrude beyond the base.

Proceeding this way, the original stack height of the heatsink assembly should be preserved. This should not affect the stiffness of the heatsink significantly.

Figure 29. Load Cell Installation in Machined Heatsink Base Pocket - Bottom View

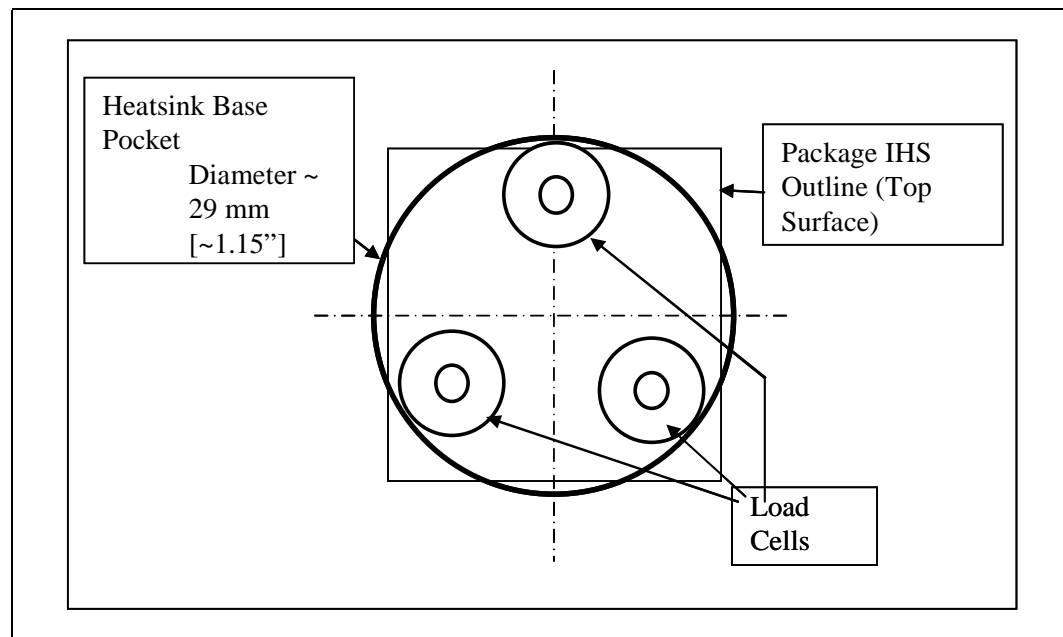

Figure 30. Load Cell Installation in Machined Heatsink Base Pocket - Side View

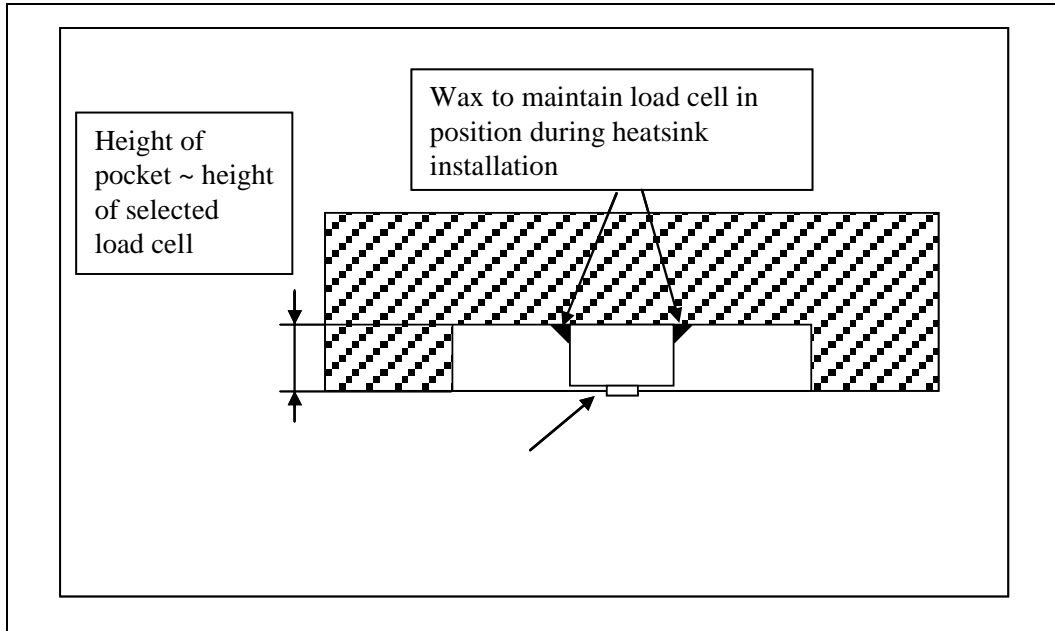
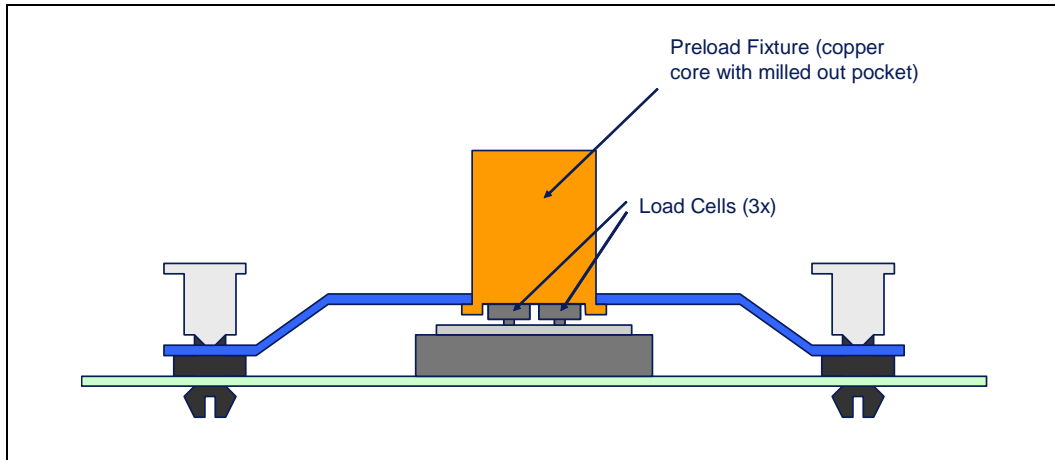

Figure 31. Preload Test Configuration





B.2.2 Typical Test Equipment

For the heatsink clip load measurement, use equivalent test equipment to the one listed [Table 10](#).

Table 10. Typical Test Equipment

Item	Description	Part Number (Model)
Load cell Notes: 1, 5	Honeywell*-Sensotec* Model 13 subminiature load cells, compression only Select a load range depending on load level being tested. www.sensotec.com	AL322BL
Data Logger (or scanner) Notes: 2, 3, 4	Vishay* Measurements Group Model 6100 scanner with a 6010A strain card (one card required per channel).	Model 6100

Notes:

- Select load range depending on expected load level. It is usually better, whenever possible, to operate in the high end of the load cell capability. Check with your load cell vendor for further information.
- Since the load cells are calibrated in terms of mV/V, a data logger or scanner is required to supply 5 volts DC excitation and read the mV response. An automated model will take the sensitivity calibration of the load cells and convert the mV output into pounds.
- With the test equipment listed above, it is possible to automate data recording and control with a 6101-PCI card (GPIB) added to the scanner, allowing it to be connected to a PC running LabVIEW* or Vishay's StrainSmart* software.
- IMPORTANT:** In addition to just a zeroing of the force reading at no applied load, it is important to calibrate the load cells against known loads. Load cells tend to drift. Contact your load cell vendor for calibration tools and procedure information.
- When measuring loads under thermal stress (bake for example), load cell thermal capability must be checked, and the test setup must integrate any hardware used along with the load cell. For example, the Model 13 load cells are temperature compensated up to 71 °C, as long as the compensation package (spliced into the load cell's wiring) is also placed in the temperature chamber. The load cells can handle up to 121 °C (operating), but their uncertainty increases according to 0.02% rdg/°F.

B.2.3 Test Procedure Examples

The following sections give two examples of load measurement. However, this is not meant to be used in mechanical shock and vibration testing.

Any mechanical device used along with the heatsink attach mechanism will need to be included in the test setup (i.e., back plate, attach to chassis, etc.).

Prior to any test, make sure that the load cell has been calibrated against known loads, following load cell vendor's instructions.

B.2.4 Time-Zero, Room Temperature Preload Measurement

- Pre-assemble mechanical components on the board as needed prior to mounting the motherboard on an appropriate support fixture that replicate the board attach to a target chassis.
For example: If the attach mechanism includes fixtures on the back side of the board, those must be included, as the goal of the test is to measure the load provided by the actual heatsink mechanism.
- Install the test vehicle in the socket.
- Assemble the heatsink reworked with the load cells to motherboard as shown for the Quad-Core Intel® Xeon® processor 5300 series CEK-reference heatsink example in [Figure 31](#), and actuate attach mechanism.
- Collect continuous load cell data at 1 Hz for the duration of the test. A minimum time to allow the load cell to settle is generally specified by the load cell vendors (often on the order of 3 minutes). The time zero reading should be taken at the end of this settling time.



5. Record the preload measurement (total from all three load cells) at the target time and average the values over 10 seconds around this target time as well, i.e. in the interval for example over [target time – 5 seconds; target time + 5 seconds].

B.2.5 Preload Degradation under Bake Conditions

This section describes an example of testing for potential clip load degradation under bake conditions.

1. Preheat thermal chamber to target temperature (45 °C or 85 °C for example).
2. Repeat time-zero, room temperature preload measurement.
3. Place unit into preheated thermal chamber for specified time.
4. Record continuous load cell data as follows:
 - Sample rate = 0.1 Hz for first 3 hrs
 - Sample rate = 0.01 Hz for the remainder of the bake test
5. Remove assembly from thermal chamber and set into room temperature conditions
6. Record continuous load cell data for next 30 minutes at sample rate of 1 Hz.

§



Appendix C Safety Requirements

Heatsink and attachment assemblies shall be consistent with the manufacture of units that meet the safety standards:

1. UL Recognition-approved for flammability at the system level. All mechanical and thermal enabling components must be a minimum UL94V-2 approved.
2. CSA Certification. All mechanical and thermal enabling components must have CSA certification.
3. Heatsink fins must meet the test requirements of UL1439 for sharp edges.

§



Appendix D Quality and Reliability Requirements

D.1 Intel Verification Criteria for the Reference Designs

D.1.1 Reference Heatsink Thermal Verification

The Intel reference heatsinks will be verified within specific boundary conditions using a TTV and the methodology described in the *Intel® Xeon® Processor Family Thermal Test Vehicle User's Guide*.

The test results, for a number of samples, are reported in terms of a worst-case mean + 3σ value for thermal characterization parameter using real processors (based on the TTV correction offset).

D.1.2 Environmental Reliability Testing

D.1.2.1 Structural Reliability Testing

The Intel reference heatsinks will be tested in an assembled condition, along with the LGA771 Socket. Details of the Environmental Requirements, and associated stress tests, can be found in the *LGA771 Socket Mechanical Design Guide*.

The use condition environment definitions provided in [Appendix 11](#) are based on speculative use condition assumptions, and are provided as examples only.

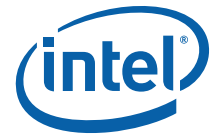

Table 11. Use Conditions Environment

Use Environment	Speculative Stress Condition	Example Use Condition	Example 7-Yr Stress Equiv.	Example 10-Yr Stress Equiv.														
Shipping and Handling	<u>Mechanical Shock</u> <ul style="list-style-type: none"> System-level Unpackaged Trapezoidal 25 g velocity change is based on packaged weight 	Total of 12 drops per system: <ul style="list-style-type: none"> 2 drops per axis ± direction 	n/a	n/a														
	<table border="1"> <tr> <td>Product Weight (lbs)</td> <td>Non-palletized Product Velocity Change[†] (in/sec)</td> </tr> <tr> <td>< 20 lbs</td> <td>250</td> </tr> <tr> <td>20 to > 40</td> <td>225</td> </tr> <tr> <td>40 to > 80</td> <td>205</td> </tr> <tr> <td>80 to < 100</td> <td>175</td> </tr> <tr> <td>100 to < 120</td> <td>145</td> </tr> <tr> <td>≥120</td> <td>125</td> </tr> </table>	Product Weight (lbs)	Non-palletized Product Velocity Change [†] (in/sec)	< 20 lbs	250	20 to > 40	225	40 to > 80	205	80 to < 100	175	100 to < 120	145	≥120	125			
	Product Weight (lbs)	Non-palletized Product Velocity Change [†] (in/sec)																
< 20 lbs	250																	
20 to > 40	225																	
40 to > 80	205																	
80 to < 100	175																	
100 to < 120	145																	
≥120	125																	
[†] Change in velocity is based upon a 0.5 coefficient of restitution.																		
Shipping and Handling	<u>Random Vibration</u> <ul style="list-style-type: none"> System Level Unpackaged 5 Hz to 500 Hz 2.20 g RMS random 5 Hz @ .001 g²/Hz to 20 Hz @ 0.01 g²/Hz (slope up) 20 Hz to 500 Hz @ 0.01 g²/Hz (flat) Random control limit tolerance is ± 3 dB 	<u>Total per system:</u> <ul style="list-style-type: none"> 10 minutes per axis 3 axes 	n/a	n/a														

Note: In the case of a discrepancy, information in the most recent LGA771 Socket Mechanical Design Guidelines supersedes that in the Table 11 above.

D.1.2.2 Recommended Test Sequence

Each test sequence should start with components (i.e. baseboard, heatsink assembly, etc.) that have not been previously submitted to any reliability testing.

The test sequence should always start with a visual inspection after assembly, and BIOS/Processor/memory test. The stress test should be then followed by a visual inspection and then BIOS/Processor/memory test.

D.1.2.3 Post-Test Pass Criteria

The post-test pass criteria are:

1. No significant physical damage to the heatsink and retention hardware.



2. Heatsink remains seated and its bottom remains mated flatly against the IHS surface. No visible gap between the heatsink base and processor IHS. No visible tilt of the heatsink with respect to the retention hardware.
3. No signs of physical damage on baseboard surface due to impact of heatsink.
4. No visible physical damage to the processor package.
5. Successful BIOS/Processor/memory test of post-test samples.
6. Thermal compliance testing to demonstrate that the case temperature specification can be met.

D.1.2.4 Recommended BIOS/Processor/Memory Test Procedures

This test is to ensure proper operation of the product before and after environmental stresses, with the thermal mechanical enabling components assembled. The test shall be conducted on a fully operational baseboard that has not been exposed to any battery of tests prior to the test being considered.

Testing setup should include the following components, properly assembled and/or connected:

- Appropriate system baseboard.
- Processor and memory.
- All enabling components, including socket and thermal solution parts.

The pass criterion is that the system under test shall successfully complete the checking of BIOS, basic processor functions and memory, without any errors. *Intel PC Diags* is an example of software that can be utilized for this test.

D.1.3 Material and Recycling Requirements

Material shall be resistant to fungal growth. Examples of non-resistant materials include cellulose materials, animal and vegetable based adhesives, grease, oils, and many hydrocarbons. Synthetic materials such as PVC formulations, certain polyurethane compositions (e.g. polyester and some polyethers), plastics which contain organic fillers of laminating materials, paints, and varnishes also are susceptible to fungal growth. If materials are not fungal growth resistant, then MIL-STD-810E, Method 508.4 must be performed to determine material performance.

Material used shall not have deformation or degradation in a temperature life test.

Any plastic component exceeding 25 grams should be recyclable per the European Blue Angel recycling standards.

The following definitions apply to the use of the terms lead-free, Pb-free, and RoHS compliant.

Lead-free and Pb-free: Lead has not been intentionally added, but lead may still exist as an impurity below 1000 ppm.

RoHS compliant: Lead and other materials banned in RoHS Directive are either (1) below all applicable substance thresholds as proposed by the EU or (2) an approved/pending exemption applies.

Note: RoHS implementation details are not fully defined and may change.

§

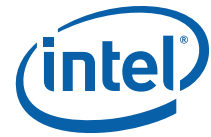

Appendix E Enabled Suppliers Information

E.1 Supplier Information

E.1.1 Intel Enabled Suppliers

The Intel reference enabling solution for Dual-Core Intel Xeon Processor 5300 Series in AdvancedTCA is preliminary. The Intel reference solutions have not been verified to meet the criteria outlined in [Appendix D](#). Customers can purchase the Intel reference thermal solution components from the suppliers listed in [Table 12](#).

For additional details, please refer to the Dual-Core Intel Xeon Processor 5300 Series thermal mechanical enabling components drawings in [Appendix A](#).

Table 12. Suppliers for the Dual-Core Intel Xeon Processor 5300 Series Intel Reference Solution

Assembly	Component	Description	Development Suppliers	Supplier Contact Info
AdvancedTCA* Heatsink	AdvancedTCA* Heatsinks P/N: ECC-00267-01-GP	Copper Fin, Copper Base includes PCM45F TIM+cover	Cooler Master*	Cooler Master* Wendy Lin 510-770-8566, x211 wendy@coolermaster.com
	Thermal Interface Material	Grease	Shin-Etsu G751 CNDA 75610	Donna Hartigan (480) 893-8898
	CEK Spring for CEK771 Intel p/n D13646 rev04	Stainless Steel 301, Kapton* Tape on Reinforced Spring Fingers	AVC CNDA 2085011	David Chao 886-2-22996390 x619 david_chao@avc.com.tw

§

