



# Mobile Intel<sup>®</sup> 915GM/915GME/ 910GML Express Chipset GMCH

Thermal Design Guide

---

*October 2007*



INFORMATION IN THIS DOCUMENT IS PROVIDED IN CONNECTION WITH INTEL® PRODUCTS. NO LICENSE, EXPRESS OR IMPLIED, BY ESTOPPEL OR OTHERWISE, TO ANY INTELLECTUAL PROPERTY RIGHTS IS GRANTED BY THIS DOCUMENT. EXCEPT AS PROVIDED IN INTEL'S TERMS AND CONDITIONS OF SALE FOR SUCH PRODUCTS, INTEL ASSUMES NO LIABILITY WHATSOEVER, AND INTEL DISCLAIMS ANY EXPRESS OR IMPLIED WARRANTY, RELATING TO SALE AND/OR USE OF INTEL PRODUCTS INCLUDING LIABILITY OR WARRANTIES RELATING TO FITNESS FOR A PARTICULAR PURPOSE, MERCHANTABILITY, OR INFRINGEMENT OF ANY PATENT, COPYRIGHT OR OTHER INTELLECTUAL PROPERTY RIGHT. Intel products are not intended for use in medical, life saving, life sustaining, critical control or safety systems, or in nuclear facility applications.

Intel may make changes to specifications and product descriptions at any time, without notice. Designers must not rely on the absence or characteristics of any features or instructions marked "reserved" or "undefined." Intel reserves these for future definition and shall have no responsibility whatsoever for conflicts or incompatibilities arising from future changes to them. The information here is subject to change without notice. Do not finalize a design with this information.

The products described in this document may contain design defects or errors known as errata which may cause the product to deviate from published specifications. Current characterized errata are available on request.

Contact your local Intel sales office or your distributor to obtain the latest specifications and before placing your product order.

Copies of documents which have an order number and are referenced in this document, or other Intel literature, may be obtained by calling 1-800-548-4725, or by visiting [Intel's Web Site](#).

Any software source code reprinted in this document is furnished under a software license and may only be used or copied in accordance with the terms of that license.

Intel processor numbers are not a measure of performance. Processor numbers differentiate features within each processor family, not across different processor families. See [http://www.intel.com/products/processor\\_number](http://www.intel.com/products/processor_number) for details.

Code Names are only for use by Intel to identify products, platforms, programs, services, etc. ("products") in development by Intel that have not been made commercially available to the public, i.e., announced, launched or shipped. They are never to be used as "commercial" names for products. Also, they are not intended to function as trademarks.

BunnyPeople, Celeron, Celeron Inside, Centrino, Centrino logo, Core Inside, FlashFile, i960, InstantIP, Intel, Intel logo, Intel386, Intel486, Intel740, IntelDX2, IntelDX4, IntelSX2, Intel Core, Intel Inside, Intel Inside logo, Intel Leap ahead., Intel Leap ahead. logo, Intel NetBurst, Intel NetMerge, Intel NetStructure, Intel SingleDriver, Intel SpeedStep, Intel StrataFlash, Intel Viiv, Intel vPro, Intel XScale, Itanium, Itanium Inside, MCS, MMX, Oplus, OverDrive, PDCharm, Pentium, Pentium Inside, skool, Sound Mark, The Journey Inside, VTune, Xeon, and Xeon Inside are trademarks of Intel Corporation in the U.S. and other countries.

\*Other names and brands may be claimed as the property of others.

Copyright © 2005 – 2007, Intel Corporation. All rights reserved.

This device is protected by U.S. patent numbers 5,315,448 and 6,516,132, and other intellectual property rights. The use of Macrovision's copy protection technology in the device must be authorized by Macrovision and is intended for home and other limited pay-per-view uses only, unless otherwise authorized in writing by Macrovision. Devices incorporating Macrovision's copy protection technology can only be sold or distributed to companies appearing on Macrovision's list of "Authorized Buyers" at: [www.macrovision.com](http://www.macrovision.com). Reverse engineering or disassembly is prohibited.

# Contents

---

|       |   |    |
|-------|---|----|
| 1     | Introduction.....                                   | 6  |
| 1.1   | Scope.....  | 6  |
| 1.2   | Terminology .....                                   | 6  |
| 1.3   | Reference Documents .....                           | 7  |
| 2     | Product Specifications .....                        | 8  |
| 2.1   | Package Description .....                           | 8  |
| 2.1.1 | Grid Array Package Ball Placement.....              | 8  |
| 2.2   | Thermal Specifications .....                        | 9  |
| 2.3   | Thermal Design Power (TDP).....                     | 9  |
| 2.3.1 | Application Power .....                             | 9  |
| 2.3.2 | Specifications.....                                 | 10 |
| 3     | Thermal Metrology.....                              | 12 |
| 3.1   | Case Temperature Measurements .....                 | 12 |
| 3.1.1 | Thermocouple Attach Methodology .....               | 12 |
| 3.2   | Airflow Characterization.....                       | 14 |
| 4     | Reference Thermal Solution .....                    | 15 |
| 4.1   | Operating Environment and Thermal Performance ..... | 15 |
| 4.2   | Mechanical Design Envelope .....                    | 16 |
| 4.3   | Thermal Solution Assembly .....                     | 17 |
| 4.3.1 | Heatsink Orientation .....                          | 18 |
| 4.3.2 | Heatsink Clip.....                                  | 18 |
| 4.3.3 | Solder-Down Anchors.....                            | 18 |
| 4.3.4 | Thermal Interface Material (TIM) .....              | 18 |
| 4.4   | Board-Level Component Keep-outs .....               | 19 |
| 4.5   | Environmental Reliability Requirements .....        | 20 |
| 5     | Thermal Management .....                            | 22 |
| 5.1   | Internal Thermal Sensor .....                       | 22 |
| 5.1.1 | Trip Points.....                                    | 22 |
| 5.1.2 | Thermometer .....                                   | 23 |
| 5.2   | Sample Programming Model .....                      | 23 |
| 5.2.1 | Setting the “Hot” Temperature Trip Point.....       | 23 |
| 5.3   | Trip Point Temperature Targets.....                 | 24 |
| 5.4   | Thermal Sensor Accuracy .....                       | 24 |
| 5.5   | Thermal Throttling Options .....                    | 24 |
| 5.6   | THRMTRIP Operation .....                            | 25 |
| 6     | Conclusion.....                                     | 26 |
| A     | Enabled Suppliers .....                             | 27 |
| B     | Mechanical Drawings .....                           | 28 |

## Figures

|    |   |    |
|----|---|----|
| 1  | Mobile Intel® 915GM/915GME/910GMLE Express Chipset GMCH Solder Ball Grid Array .....            | 8  |
| 2  | 0° Angle Attach Heatsink Modifications.....   | 13 |
| 3  | 0° Angle Attach Methodology .....   | 13 |
| 4  | Airflow Temperature Measurement Locations.....  | 14 |
| 5  | Mobile Intel® 915GM/915GME/910GMLE Express Chipset GMCH Aluminum Heatsink Thermal Performance16 |    |
| 6  | Reference Heatsink Volumetric Height.....   | 17 |
| 7  | Reference Thermal Solution Heatsink Assembly .....  | 18 |
| 8  | Torsional Clip Heatsink Motherboard Component Keep-out .....                                    | 19 |
| 9  | Retention Mechanism Component Keep-out Zones.....   | 20 |
| 10 | Mobile Intel® 915GM/915GME/910GMLE Express Chipset GMCH Package.....                            | 29 |
| 11 | Mobile Intel® 915GM/915GME/910GMLE Express Chipset GMCH Aluminum Heatsink Assembly 30           |    |
| 12 | Mobile Intel® 915GM/915GME/910GMLE Express Chipset GMCH Aluminum Heatsink.....                  | 31 |
| 13 | Torsional Clip.....   | 32 |

## Tables

|   |   |    |
|---|---|----|
| 1 | Terminology.....  | 6  |
| 2 | Reference Documents.....  | 7  |
| 3 | Mobile Intel® 915GM/915GME/910GMLE Express Chipset GMCH Case Temperature Specifications9              |    |
| 4 | Mobile Intel® 915GM/915GME/910GMLE Express Chipset GMCH Thermal Design Power Specifications11         |    |
| 5 | Mobile Intel® 915GM/915GME/910GMLE Express Chipset GMCH Thermal Requirements .....                    | 15 |
| 6 | Reference Thermal Solution Environmental Reliability Requirements .....                               | 20 |
| 7 | Recommended Programming for Available Trip Points.....  | 24 |
| 8 | Mobile Intel® 915GM/915GME/910GMLE Express Chipset GMCH Reference Design Heatsink Enabled Suppliers27 |    |
| 9 | Mechanical Drawings .....   | 28 |

## Revision History

---

| Date         | Revision | Description                           |
|--------------|----------|---------------------------------------|
| October 2007 | 003      | Added 910GMLE information to document |
| May 2007     | 002      | Added 915GME information to document  |
| Feb 2005     | 001      | Initial release                       |

# Introduction

# 1

The objective of thermal management is to ensure that the temperatures of all components in a system are maintained within functional limits. The functional temperature limit is the range within which the electrical circuits can be expected to meet specified performance requirements. Operation outside the functional limit can degrade system performance, cause logic errors, or cause component and/or system damage. Temperatures exceeding the maximum operating limits may result in irreversible changes in the operating characteristics of the component. The goal of this document is to provide an understanding of the operating limits of the Mobile Intel® 915GM/915GME/910GMLE Express Chipset GMCH and discuss a reference thermal solution.

The simplest and most cost-effective method to improve the inherent system cooling characteristics of the 915GM/915GME/910GMLE GMCH is through careful design and placement of fans, vents, and ducts. When additional cooling is required, component thermal solutions may be implemented in conjunction with system thermal solutions. The 915GM/915GME/910GMLE GMCH requires a heatsink to maintain component temperature specifications.

## 1.1 Scope

This document presents conditions and requirements to properly design a cooling solution for systems that implement the 915GM/915GME/910GMLE GMCH. Specifically it applies to implementation in embedded applications and form factors. Properly designed thermal solutions provide adequate cooling to maintain the 915GM/915GME/910GMLE GMCH case temperature at or below thermal specifications. This is accomplished by providing a low local-ambient temperature, ensuring adequate airflow, and minimizing case-to-local-ambient thermal resistance. By maintaining the 915GM/915GME/910GMLE GMCH case temperature at or below the specifications, a system designer can ensure the proper functionality, performance, and reliability of the chipset.

## 1.2 Terminology

Table 1 defines the terms used in this document.

**Table 1. Terminology (Sheet 1 of 2)**

| Term   | Description   |
|--------|---|
| BGA    | Ball Grid Array. A package type defined by a resin-fiber substrate where a die is mounted and bonded. The primary electrical interface is an array of solder balls attached to the substrate opposite the die and molding compound.   |
| DMI    | Direct Media Interface. The chip-to-chip inter-connect between the Mobile Intel 915GM/915GME/910GMLE Express Chipset GMCH and the ICH6-M, is an Intel proprietary interface.  |
| FC-BGA | Flip Chip Ball Grid Array. A package type defined by a plastic substrate where a die is mounted using an underfill C4 (Controlled Collapse Chip Connection) attach style. The primary electrical interface is an array of solder balls attached to the substrate opposite the die. Note that the device arrives at the customer with solder balls attached. |

**Table 1. Terminology (Sheet 2 of 2)**

| Term          | Description   |
|---------------|---|
| Intel® ICH6-M | Intel® Mobile I/O Controller Hub 6-M. The chipset component that contains the primary PCI interface, LPC interface, USB, ATA, and/or other legacy functions.  |
| mBGA          | Mini Ball Grid Array. A smaller version of the BGA.   |
| GMCH          | Graphic Memory Controller Hub. The chipset component that contains the processor and memory interface and integrated graphics core.   |
| $T_A$         | The measured ambient temperature locally to the component of interest. The ambient temperature should be measured just upstream of airflow for a passive heatsink or at the fan inlet for an active heatsink. Also referred to as $T_{LA}$ .  |
| $T_C$         | The measured case temperature of a component. It is generally measured at the geometric center of the top of the die.   |
| $T_{C-MAX}$   | The maximum case/die temperature with an attached heatsink. This temperature is measured at the geometric center of the top of the package case/die.  |
| $T_{C-MIN}$   | The minimum case/die temperature with an attached heatsink. This temperature is measured at the geometric center of the top of the package case/die.  |
| TDP           | Thermal Design Power. Specified as the highest sustainable power level of most or all of the real applications expected to be run on the given product, based on extrapolations in both hardware and software technology over the life of the component. Thermal solutions should be designed to dissipate this target power level. |
| TIM           | Thermal Interface Material. Thermally conductive material installed between two surfaces to improve heat transfer and reduce interface contact resistance.  |
| lfm           | Linear Feet per Minute. Unit of airflow speed.  |
| $V_{CC}$      | The core voltage of the 915GM/915GME/910GMLE Express Chipset GMCH.  |
| $V_{TT}$      | Processor side bus power supply (VCCP).   |
| $\Psi_{CA}$   | Case-to-ambient thermal characterization parameter (Psi). A measure of thermal solution performance using total package power. Defined as $(T_C - T_A)/\text{Total Package Power}$ . Heat source size should always be specified for $\Psi$ measurements.   |

## 1.3 Reference Documents

The following table lists reference documents to be used in conjunction with the 915GM/915GME/910GMLE GMCH. Contact your Intel field sales representative for the latest revision and order number of these documents.

**Table 2. Reference Documents**

| Title  | Document Number |
|--|-----------------|
| Intel® Pentium® M Processor on 90nm Process with 2-MB L2 Cache for Embedded Applications Thermal Design Guide        | 302231          |
| Intel® Pentium® M Processor with 2-MB L2 Cache and 533-MHz System Bus for Embedded Applications Thermal Design Guide | 305993          |
| Mobile Intel® 915PM/GM/GMS and 910GML Express Chipset Datasheet  | 305264          |

# Product Specifications

# 2

## 2.1 Package Description

The 915GM/915GME/910GMLE GMCH is available in a 40.0 mm [1.57 in] x 37.5 mm [1.48 in] Flip Chip Ball Grid Array (FC-BGA) package with 1257 solder balls. The die size is 10.033 mm [0.395 in] x 10.033 mm [0.395 in] and is subject to change. A mechanical drawing of the package is shown in [Figure 10](#) on page 29.

### 2.1.1 Grid Array Package Ball Placement

The 915GM/915GME/910GMLE GMCH package has solder balls arranged in a grid array pattern. For exact ball locations relative to the package, refer to the *Mobile Intel® 915PM/GM/GMS and 910GML Express Chipset Datasheet*. [Figure 1](#) shows a representation of the solder ball pattern for the 915GM/915GME/910GMLE GMCH.

**Figure 1. Mobile Intel® 915GM/915GME/910GMLE Express Chipset GMCH Solder Ball Grid Array**

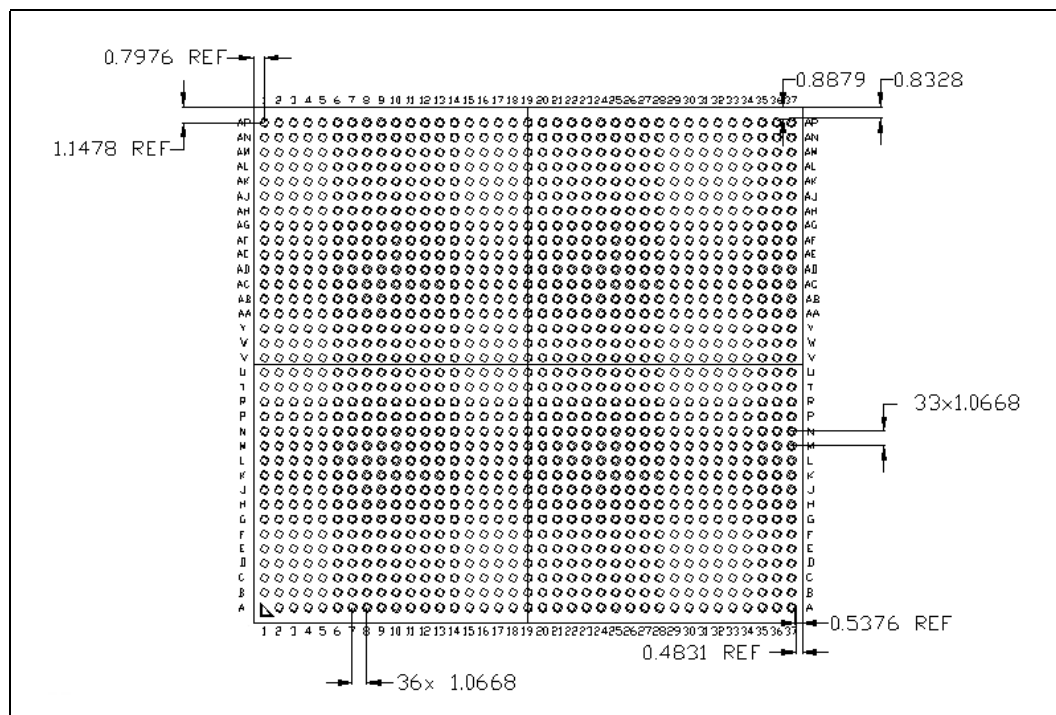

## 2.2 Thermal Specifications

To ensure proper operation and reliability of the 915GM/915GME/910GMLE GMCH, the temperature must be at or below the maximum value specified in Table 3. System and component level thermal enhancements are required to dissipate the heat generated and maintain the 915GM/915GME/910GMLE GMCH within specifications. Section 3 provides the thermal metrology guidelines for case temperature measurements.

The 915GM/915GME/910GMLE GMCH should also operate above the minimum case temperature specification listed in Table 3.

**Table 3. Mobile Intel® 915GM/915GME/910GMLE Express Chipset GMCH Case Temperature Specifications**

| Parameter   | Value  |
|-------------|--------|
| $T_{C-MAX}$ | 105 °C |
| $T_{C-MIN}$ | 0 °C   |

**Note:** Thermal specifications assume an attached heatsink is present.

## 2.3 Thermal Design Power (TDP)

Thermal design power (TDP) is the estimated power dissipation of the 915GM/915GME/910GMLE GMCH based on normal operating conditions including  $V_{CC}$  and  $T_{C-MAX}$  while executing real worst-case power intensive applications. This value is based on expected worst-case data traffic patterns and usage of the chipset and does not represent a specific software application. TDP attempts to account for expected increases in power due to variation in chipset current consumption due to silicon process variation, processor speed, DRAM capacitive bus loading and temperature. However, since these variations are subject to change, the TDP cannot guarantee that all applications will not exceed the TDP value.

The system designer must design a thermal solution for the 915GM/915GME/910GMLE GMCH such that it maintains  $T_C$  below  $T_{C-MAX}$  for a sustained power level equal to TDP. The TDP value can be used for thermal design **if the chipset thermal protection mechanisms are enabled**. Intel chipsets incorporate a hardware-based fail-safe mechanism to keep the product temperature in spec in the event of unusually strenuous usage above the TDP power.

### 2.3.1 Application Power

Designing to the TDP can ensure a particular thermal solution can meet the cooling needs of future applications. Testing with available commercial applications has shown they may dissipate power levels below the published TDP specification in Section 2.3.2. Intel strongly recommends that thermal engineers design to the published TDP specification to develop a robust thermal solution that will meet the needs of current and future applications.

## **2.3.2 Specifications**

The 915GM/915GME/910GMLE GMCH is estimated to dissipate the TDP values provided in [Table 4](#). FC-BGA packages have poor heat transfer capability into the board and have minimal thermal capability without thermal solutions. Intel requires that system designers plan for an attached heatsink when using the 915GM/915GME/910GMLE GMCH.

**Table 4. Mobile Intel® 915GM/915GME/910GMLE Express Chipset GMCH Thermal Design Power Specifications**

| Configuration  | Front Side Bus Frequency (MHz) | Memory Type | Internal Graphics Frequency (MHz) | DMI | V <sub>CC</sub> | TDP (W) |
|----------------|--------------------------------|-------------|-----------------------------------|-----|-----------------|---------|
| Single Channel | 400                            | DDR2 400    | 130                               | x 2 | 1.05            | 4.6     |
| Single Channel | 533                            | DDR2 400    | Discrete                          | x 2 | 1.05            | 4.6     |
| Single Channel | 400                            | DDR2 400    | 160                               | x 2 | 1.05            | 4.8     |
| Dual Channel   | 533                            | DDR2 400    | Discrete                          | x 2 | 1.05            | 5.1     |
| Single Channel | 533                            | DDR2 400    | 200                               | x 2 | 1.05            | 5.2     |
| Dual Channel   | 533                            | DDR2 533    | Discrete                          | x 2 | 1.05            | 5.3     |
| Dual Channel   | 533                            | DDR2 533    | Discrete                          | x 4 | 1.05            | 5.5     |
| Dual Channel   | 533                            | DDR2 400    | 200                               | x 2 | 1.05            | 5.6     |
| Dual Channel   | 533                            | DDR2 533    | 200                               | x 2 | 1.05            | 5.8     |
| Dual Channel   | 533                            | DDR2 533    | 200                               | x 4 | 1.05            | 6.0     |
| Single Channel | 533                            | DDR2 533    | Discrete                          | x 2 | 1.5             | 10.0    |
| Single Channel | 533                            | DDR2 533    | Discrete                          | x 4 | 1.5             | 10.2    |
| Dual Channel   | 533                            | DDR2 533    | Discrete                          | x 2 | 1.5             | 10.3    |
| Dual Channel   | 533                            | DDR2 533    | Discrete                          | x 4 | 1.5             | 10.5    |
| Single Channel | 533                            | DDR2 533    | 320                               | x 2 | 1.5             | 13.4    |
| Single Channel | 533                            | DDR2 533    | 320                               | x 4 | 1.5             | 13.6    |
| Dual Channel   | 533                            | DDR2 533    | 320                               | x 2 | 1.5             | 13.7    |
| Dual Channel   | 533                            | DDR2 533    | 320                               | x 4 | 1.5             | 13.9    |

# Thermal Metrology

# 3

The system designer must measure temperatures in order to accurately determine the thermal performance of the system. Intel has established guidelines for proper techniques of measuring chipset component case temperatures.

## 3.1 Case Temperature Measurements

To ensure functionality and reliability, the 915GM/915GME/910GMLE GMCH is specified for proper operation when  $T_C$  is maintained at or below the maximum temperature listed in [Table 3](#). The surface temperature at the geometric center of the die corresponds to  $T_C$ . Measuring  $T_C$  requires special care to ensure an accurate temperature reading.

Temperature differences between the temperature of a surface and the surrounding local ambient air can introduce error in the measurements. The measurement errors could be due to a poor thermal contact between the thermocouple junction and the surface of the package, heat loss by radiation and/or convection, conduction through thermocouple leads, or contact between the thermocouple cement and the heatsink base (if a heatsink is used). To minimize these measurement errors a thermocouple attach with a zero-degree methodology is recommended.

[Section 3.1.1](#) details the modifications required to measure package case temperature using a clip-attached heatsink. The reference thermal solutions presented in this document use a clip-attach mechanism.

### 3.1.1 Thermocouple Attach Methodology

1. Mill a 3.3 mm [0.13 in] diameter hole centered on bottom of the heatsink base. The milled hole should be approximately 1.5 mm [0.06 in] deep.
2. Mill a 1.3 mm [0.05 in] wide slot, 0.5 mm [0.02 in] deep, from the centered hole to one edge of the heatsink. The slot should be in the direction parallel to the heatsink fins (see [Figure 2](#)).
3. Attach thermal interface material (TIM) to the bottom of the heatsink base.
4. Cut out portions of the TIM to make room for the thermocouple wire and bead. The cutouts should match the slot and hole milled into the heatsink base.
5. Attach a 36 gauge or smaller calibrated K-type thermocouple bead or junction to the center of the top surface of the die using a high thermal conductivity cement. During this step, make sure no contact is present between the thermocouple cement and the heatsink base because any contact will affect the thermocouple reading. **It is critical that the thermocouple bead makes contact with the die** (see [Figure 3](#)).
6. Attach heatsink assembly to the 915GM/915GME/910GMLE GMCH, and route thermocouple wires out through the milled slot. Following the guidelines is critical to ensure an accurate and repeatable metrology.

Figure 2. 0° Angle Attach Heatsink Modifications

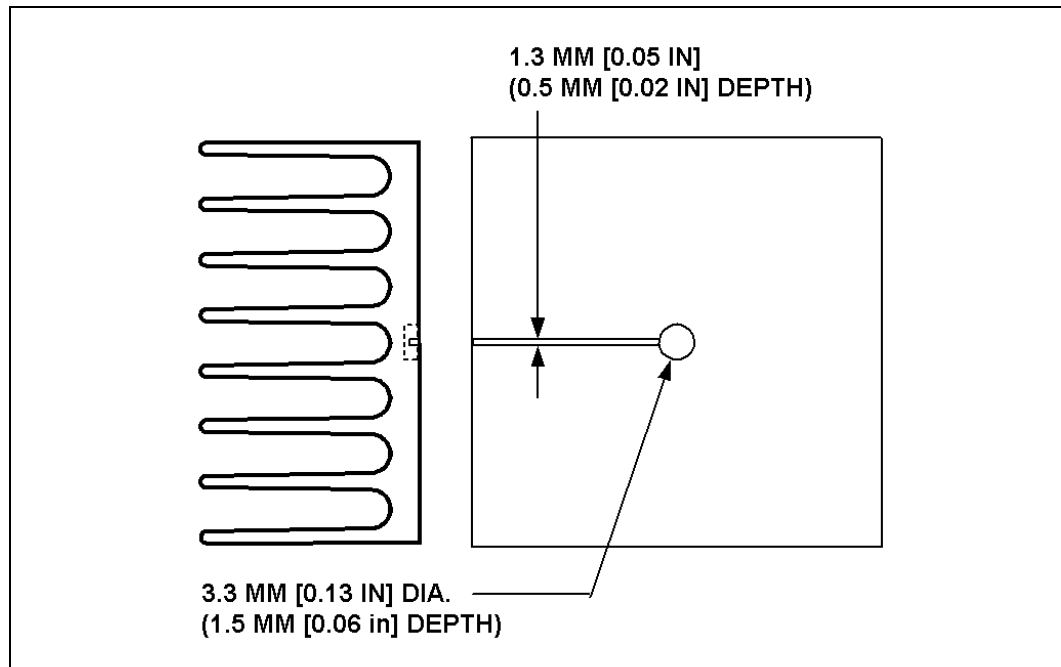

Note: Generic heatsink shown, not to scale.

Figure 3. 0° Angle Attach Methodology

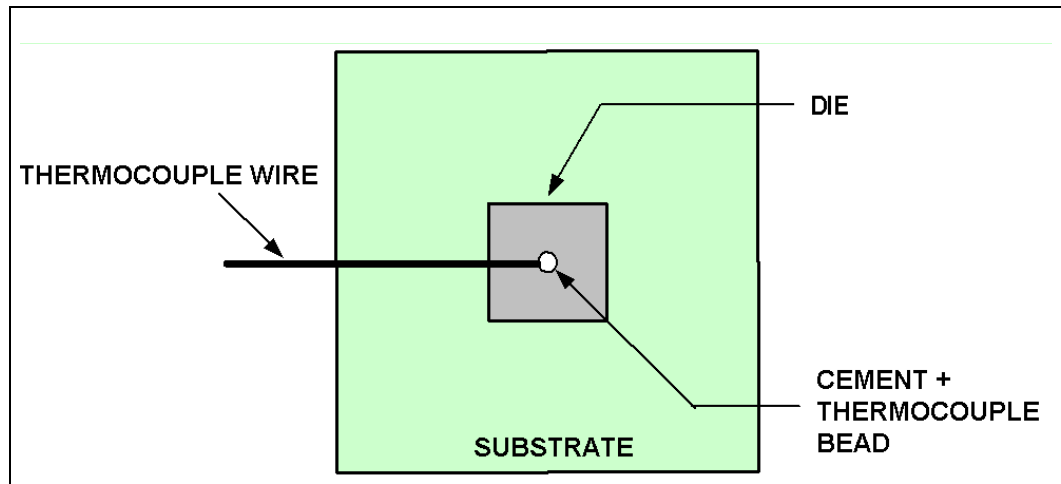

Note: Top view, not to scale.

## 3.2 Airflow Characterization

Figure 4 describes the recommended location for air temperature measurements measured relative to the component. For a more accurate measurement of the average approach air temperature, Intel recommends averaging temperatures recorded from two thermocouples spaced about 25 mm [1.0 in] apart. Locations for both a single thermocouple and a pair of thermocouples are presented.

Figure 4. Airflow Temperature Measurement Locations

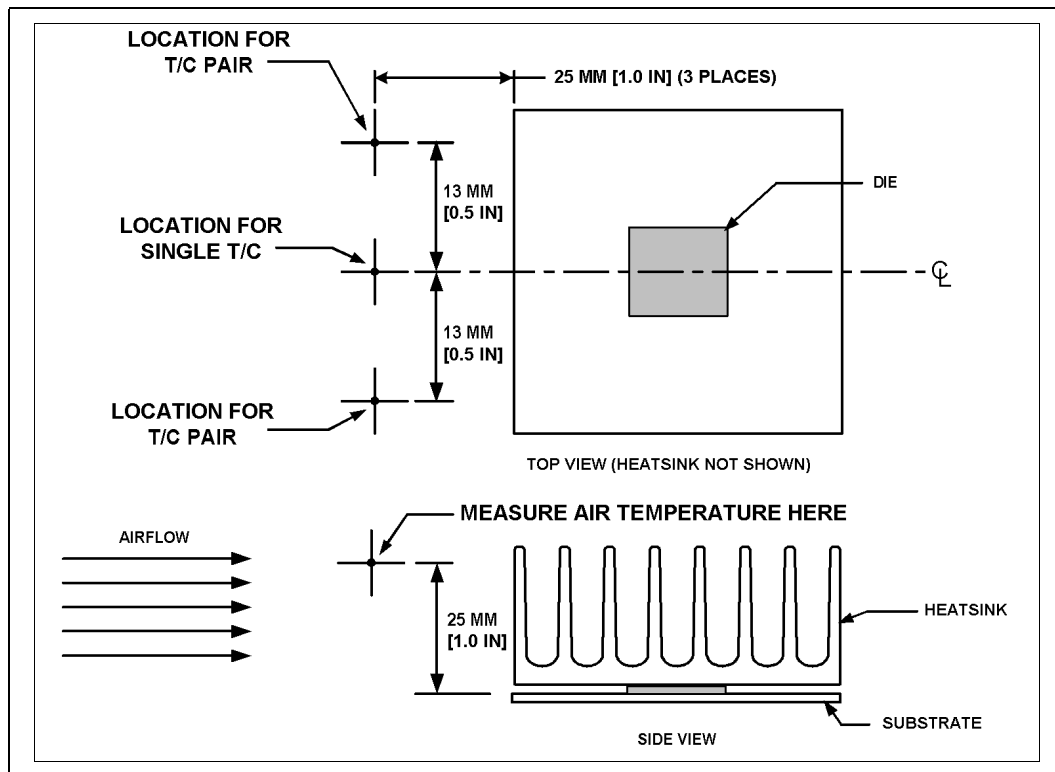

Airflow velocity should be measured using industry standard air velocity sensors. Typical airflow sensor technology may include hot wire anemometers. Figure 4 provides guidance for airflow velocity measurement locations. These locations are for a typical JEDEC test setup and may not be compatible with chassis layouts due to the proximity of the processor to the 915GM/915GME/910GMLE GMCH. The user may have to adjust the locations for a specific chassis. Be aware that sensors may need to be aligned perpendicular to the airflow velocity vector or an inaccurate measurement may result. Measurements should be taken with the chassis fully sealed in its operational configuration to achieve a representative airflow profile within the chassis.

# Reference Thermal Solution

# 4

Intel has developed an embedded reference thermal solution designed to meet the cooling needs of the Mobile Intel® 915GM/915GME/910GMLE Express Chipset GMCH. This chapter describes the overall requirements for the reference thermal solution including critical-to-function dimensions, operating environment, and validation criteria. The other components of the chipset may or may not need attached thermal solutions, depending on your specific system local-ambient operating conditions.

## 4.1 Operating Environment and Thermal Performance

Reference thermal solutions have been designed for the 915GM/915GME/910GMLE GMCH. This document will describe the reference heatsink for the 915GM/915GME/910GMLE GMCH for the 1U/2U server and AdvancedTCA\* form factors. This solution may be valid for other form factors, but the entire thermal solution, including heatsink, TIM, and attachment mechanism must be validated in the final intended system.

The reference thermal solution was designed assuming a maximum local ambient air temperature,  $T_{LA}$ , of 55° C. The required minimum airflow velocity directly upstream of the heatsink varies depending on the 915GM/915GME/910GMLE GMCH configuration and the resulting TDP. Assuming these boundary conditions are met, the reference thermal solutions will meet the thermal specifications for the 915GM/915GME/910GMLE GMCH. Table 5 shows the required thermal performance for the 915GM/915GME/910GMLE GMCH in the lowest and highest TDP configurations.

**Table 5. Mobile Intel® 915GM/915GME/910GMLE Express Chipset GMCH Thermal Requirements**

| TDP (W)                  | Required $\psi_{CA}$ at $T_{LA}^1 = 55^\circ\text{C}$ |
|--------------------------|---|
| 4.6 (Min Configuration)  | 10.87 °C/W  |
| 13.9 (Max Configuration) | 3.60 °C/W   |

**Notes:**

- $T_{LA}$  is defined as the local (internal) ambient temperature measured directly upstream of the chipset.

The thermal performance of the reference thermal solution for the 915GM/915GME/910GMLE GMCH is shown in Figure 5. This figure shows the performance of the reference thermal solution at sea level based on lab verification test data.

The performance of the heatsink is greatly influenced by the performance of the Thermal Interface Material. The TIM will have a lower impedance when first installed in the system (End of Line). Over time the material will degrade and the impedance will increase up to a point at the End of Life of the material. Figure 5 shows the performance of the thermal solution with both an End of Line and End of Life performance. It is recommended for system integrators to work with Thermal Interface Material vendors to determine the performance of the desired TIM as well as the time period for End of Life.

This thermal solution performance was tested to ensure that the heatsink is performing within expectations. It is recommended that system integrators validate the entire thermal solution, including heatsink, thermal interface material and attach mechanism, in the final intended system.

**Figure 5. Mobile Intel® 915GM/915GME/910GML Express Chipset GMCH Aluminum Heatsink Thermal Performance**

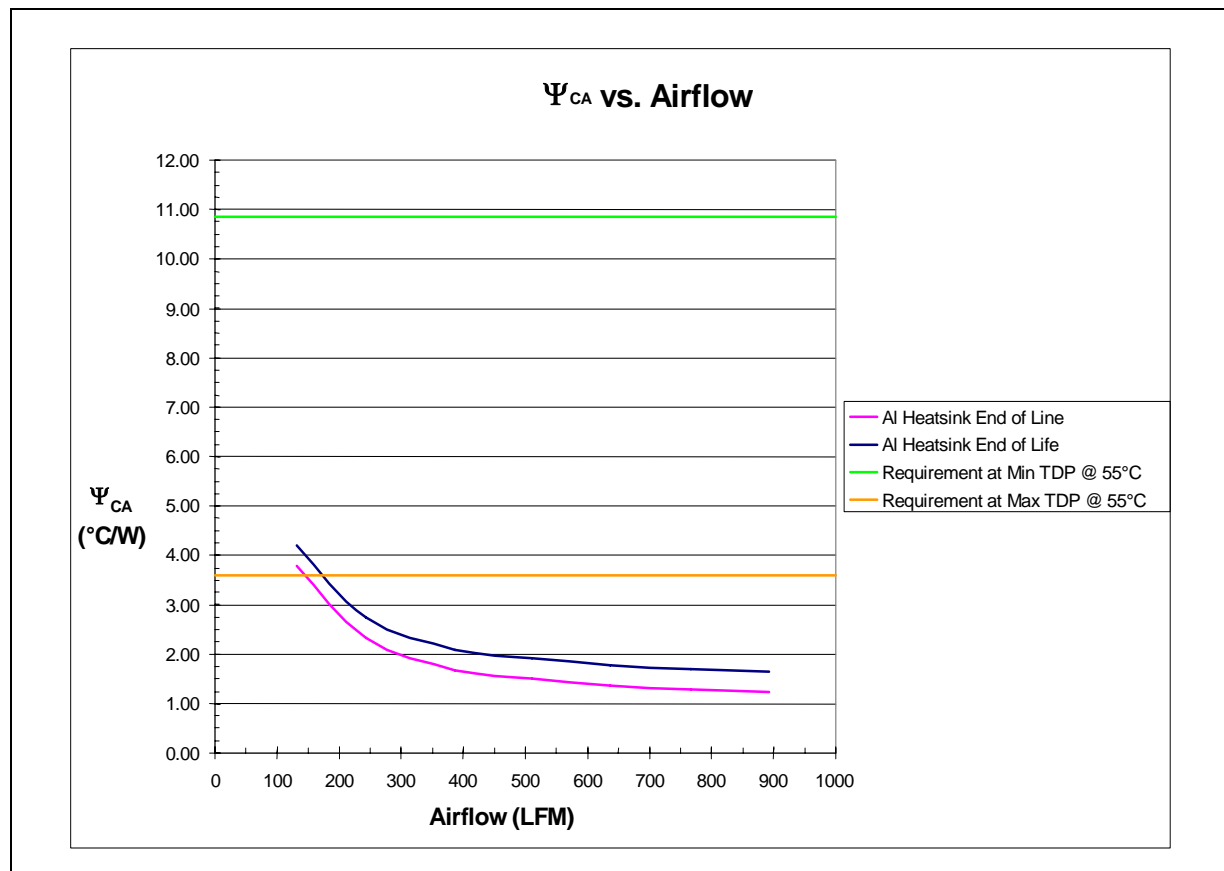

## 4.2 Mechanical Design Envelope

The board component keep-out restrictions for the reference thermal solution are included in [Section 4.4](#). [Figure 6](#) shows the reference heatsink volumetric constraints. This heatsink extends 19.42 mm [0.675 in] nominally above the board when mounted. System integrators should ensure no board or chassis components would intrude into the volume occupied by the heatsink.

Figure 6. Reference Heatsink Volumetric Height

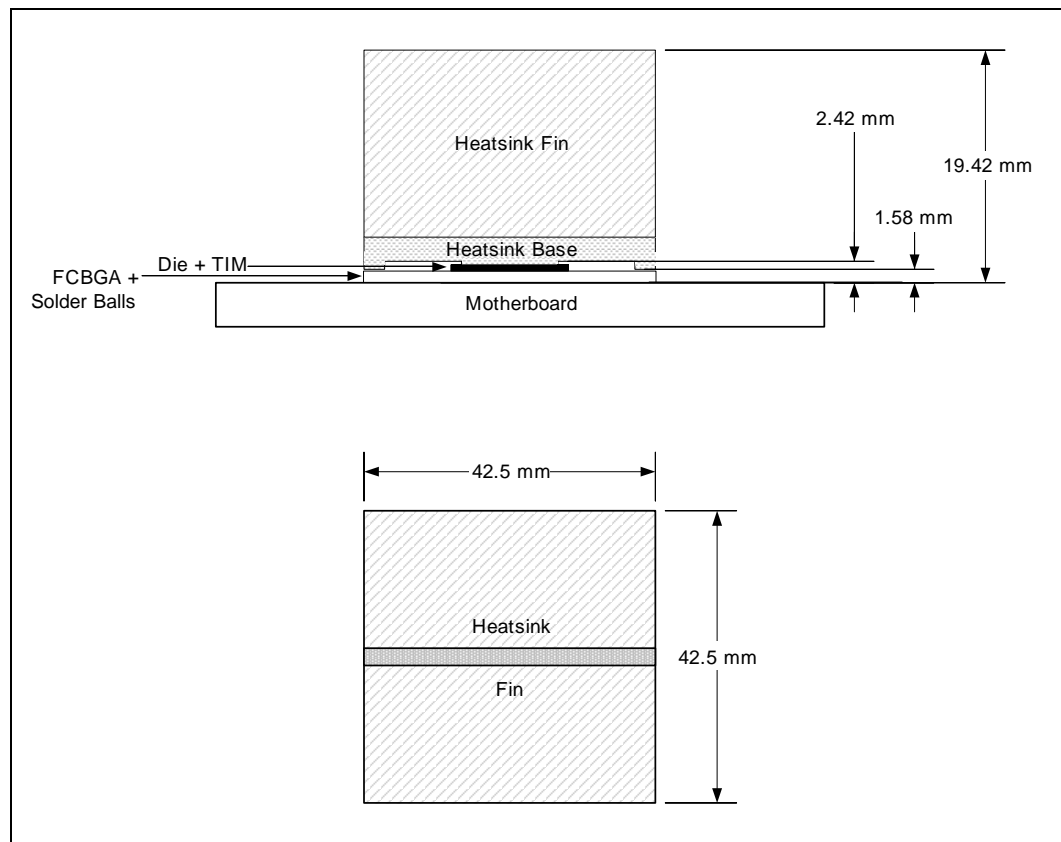

### 4.3 Thermal Solution Assembly

The reference thermal solution will consist of a passively cooled aluminum heatsink. The heatsink is comprised of an extruded or skived aluminum heatsink attached to the motherboard by a torsional clip and anchors soldered to the board. The thermal interface material for this heatsink (Honeywell\* PCM45F) is preapplied to the heatsink bottom over an area in contact with the package die. The heatsink assembly is shown in [Figure 7](#).

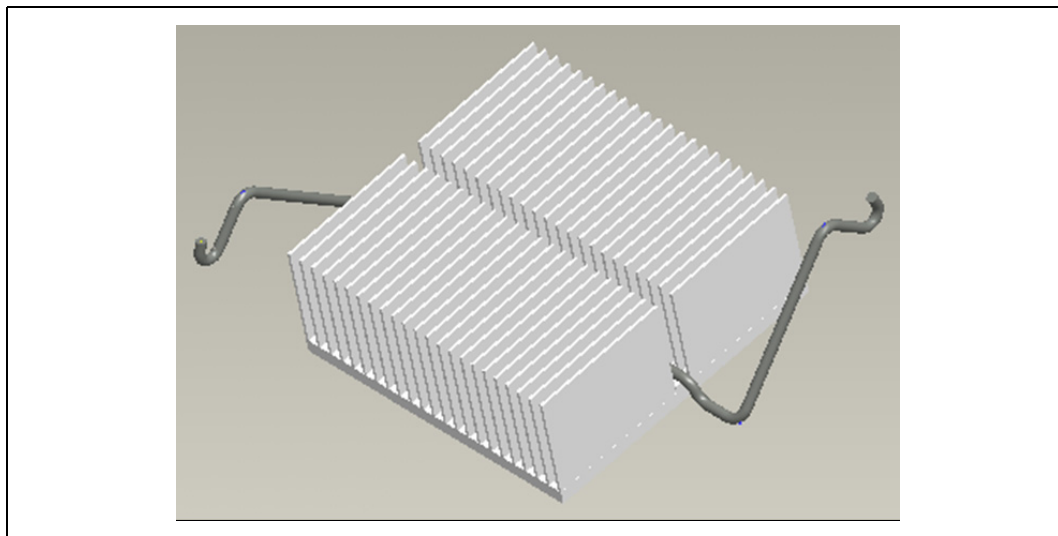
**Figure 7. Reference Thermal Solution Heatsink Assembly**

### 4.3.1 Heatsink Orientation

The 915GM/915GME/910GMLE GMCH heatsink is a unidirectional fin heatsink. This type of heatsink design requires that the fins must be aligned with the direction of the airflow.

### 4.3.2 Heatsink Clip

The reference thermal solution uses a wire clip with hooked ends. The hooks attach to wire anchors to fasten the heatsink to the board. The mechanical drawing of the clip is located in [Appendix B](#).

### 4.3.3 Solder-Down Anchors

For platforms that have very limited board space, a clip retention solder-down anchor has been developed to minimize the impact of clip retention on the board. It is based on a standard three-pin jumper and is soldered to the board like any common through-hole header. A new anchor design is available with 45° bent leads to increase the anchor attach reliability over time. The part number and vendor information is contained in [Appendix A](#).

### 4.3.4 Thermal Interface Material (TIM)

A thermal interface material provides improved conductivity between the die and heatsink. It is important to understand and consider the impact of the interface between the die and heatsink base on the overall thermal solution. Specifically, the bond line thickness, interface material area, and interface material thermal conductivity must be selected to optimize the thermal solution.

It is important to minimize the thickness of the TIM, commonly referred to as the bond line thickness. A large gap between the heatsink base and the die yields a greater thermal resistance. The thickness of the gap is determined by the flatness of both the heatsink base and the die, plus the

thickness of the TIM, and the clamping force applied by the heatsink attachment method. To ensure proper and consistent thermal performance, the TIM and application process must be properly designed.

The 915GM/915GME/910GMLE GMCH reference thermal solution uses Honeywell\* PCM45F. Alternative materials can be used at the user’s discretion. Regardless, the entire heatsink assembly, including the heatsink, TIM, attach method must be validated for specific applications.

## 4.4 Board-Level Component Keep-outs

The locations of the hole patterns and motherboard component keep-outs for the 915GM/915GME/910GMLE GMCH can be seen in Figure 8 and Figure 9. Dimensions are in inches.

**Figure 8. Torsional Clip Heatsink Motherboard Component Keep-out**

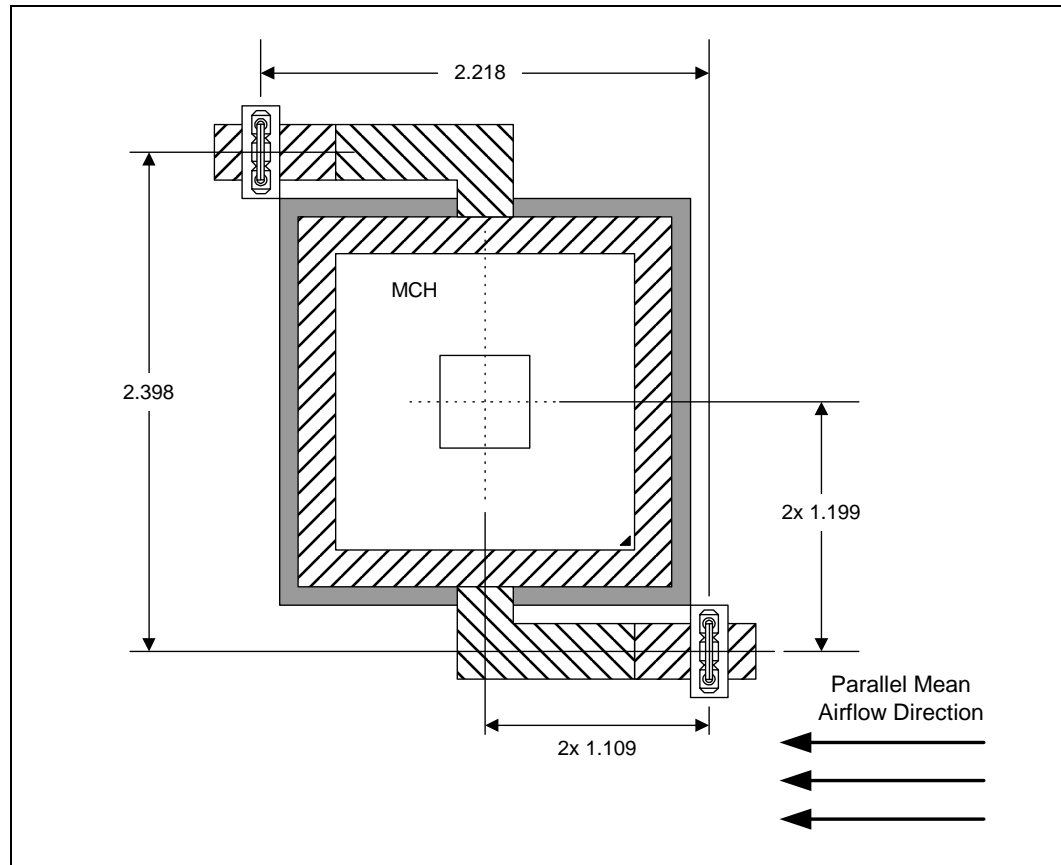
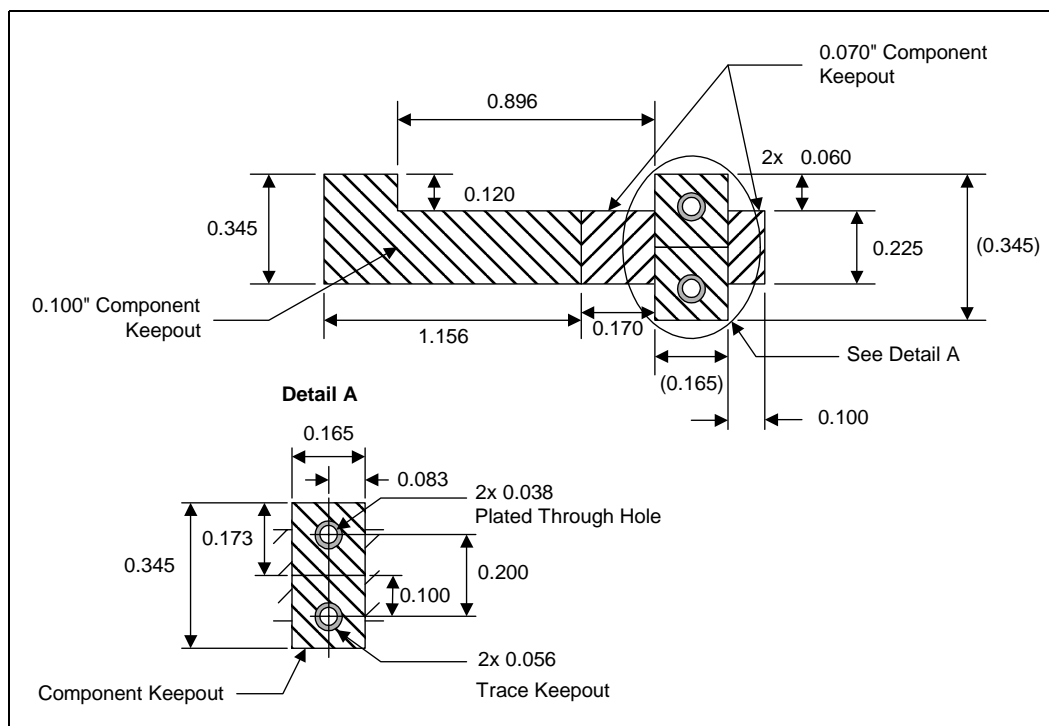

Figure 9. Retention Mechanism Component Keep-out Zones



## 4.5 Environmental Reliability Requirements

The environmental reliability requirements for the reference thermal solution are shown in Table 6. These should be considered as general guidelines. Validation test plans should be defined by the user based on anticipated use conditions and resulting reliability requirements.

Table 6. Reference Thermal Solution Environmental Reliability Requirements (Sheet 1 of 2)

| Test <sup>1</sup> | Requirement   | Pass/Fail Criteria <sup>2</sup> |
|-------------------|---|---------------------------------|
| Mechanical Shock  | <ul style="list-style-type: none"> <li>3 drops for + and - directions in each of 3 perpendicular axes (i.e., total 18 drops).</li> <li>Profile: 50 G trapezoidal waveform, 11 ms duration, 4.3 m/s [170 in/s] minimum velocity change.</li> <li>Setup: Mount sample board on test fixture. Include 450 g processor heatsink.</li> </ul> | Visual/Electrical Check         |
| Random Vibration  | <ul style="list-style-type: none"> <li>Duration: 10 min/axis, 3 axes</li> <li>Frequency Range: 5 Hz to 500 Hz</li> <li>Power Spectral Density (PSD) Profile: 3.13 g RMS</li> </ul>  | Visual/Electrical Check         |

- The above tests should be performed on a sample size of at least 12 assemblies from three different lots of material.
- Additional Pass/Fail Criteria may be added at the discretion of the user.

**Table 6. Reference Thermal Solution Environmental Reliability Requirements (Sheet 2 of 2)**

| Test <sup>1</sup> | Requirement                                | Pass/Fail Criteria <sup>2</sup> |
|-------------------|--|---------------------------------|
| Thermal Cycling   | -40 °C to +85 °C, 1000 cycles              | Visual Check                    |
| Temperature Life  | 85 °C, 1000 hours total                    | Visual/Electrical Check         |
| Unbiased Humidity | 85 % relative humidity / 55 °C, 1000 hours | Visual Check                    |

1. The above tests should be performed on a sample size of at least 12 assemblies from three different lots of material.
2. Additional Pass/Fail Criteria may be added at the discretion of the user.

# Thermal Management

# 5

System level thermal management requires comprehending thermal solutions for two domains of operation:

1. **Robust Thermal Solution Design:** Proper system design should include implementation of a robust thermal solution. The system's thermal solution should be capable of dissipating the platform's TDP power while keeping all components (particularly GMCH, for the purposes of this discussion) below the relevant  $T_{C-MAX}$  under the intended usage conditions. Such conditions include ambient air temperature and available airflow inside the notebook.
2. **Thermal Failsafe Protection Assistance:** As a backup to the implemented thermal solution, the system design should provide a method to provide additional thermal protection for the components of concern (particularly GMCH, for purposes of this discussion). The failsafe assistance mechanism is to help manage components from being damaged by excessive thermal stress under situations in which the implemented thermal solution is inadequate or has failed.

This section covers the thermal failsafe assistance mechanisms that are available for the GMCH and recommends a usage model designed to accomplish the failsafe Protection Assistance.

The GMCH provides two internal thermal sensors, plus hooks for an external thermal sensor mechanism. These can be used for detecting the component temperature and for triggering thermal control within the GMCH. The GMCH has implemented several silicon level thermal management features that can lower both GMCH and DDR power during periods of high activity. These features can help control temperature of the GMCH and DDR and thus help prevent thermally induced component failures. These features include:

- Memory throttling triggering by memory heating
- Memory throttling triggering by GMCH heating
- THRMTRIP# support

## 5.1 Internal Thermal Sensor

The GMCH incorporates two on-die thermal sensors which may be enabled separately. When “tripped” at various values, the thermal sensors may be programmed to cause hardware throttling and/or software interrupts. Hardware throttling includes main memory programmable throttling thresholds. Sensor trip points may also be programmed to be generated various interrupts, including SCI, SMI, SERR, or an internal graphics INTR.

### 5.1.1 Trip Points

There are three programmable temperature trip points for each of the two internal thermal sensors: Catastrophic, Hot, and Auxiliary.

The GMCH can be programmed to generate interrupts when any of these three trip points has been crossed in the upwards direction. In addition, the GMCH can be programmed to enable throttling of the DDR interface when the Catastrophic and/or Hot trip points are crossed in the upwards direction.

- Crossing the Catastrophic trip point may be programmed to generate an interrupt, enable hardware throttling, and immediately shut down the system (via Halt, or via THRMTRIP# assertion).
- Crossing the Hot trip point may be programmed to generate an interrupt and/or enable hardware throttling.
- Crossing the Auxiliary trip point can be programmed to generate an interrupt. The current state of all trip points (HOT/CAT/AUX) may be read by software via the Thermal Sensor Status Registers (TSSRs). It is recommended to use Halt or THRMTRIP# assertion on Catastrophic trip. Using an interrupt to initiate shutdown at Catastrophic temperature may be delayed since there is no guaranteed minimum interrupt service latency.

### 5.1.2 Thermometer

The Thermometer Reading Register (TRR) is primarily useful as an indicator of die temperature trending. The TRR value tends to decrease as the die temperature increases. Intel currently has no recommended end user usage model for this register. It is provided solely as an indication of temperature trending, for customer system characterization. Absolute temperature accuracy will vary from part to part. Refer to [Section 5.4](#) for more details on the sensor accuracy (Taccuracy).

## 5.2 Sample Programming Model

Intel BIOS reference code implements a thermal failsafe mechanism based upon the assumptions stated in the beginning of this chapter. The subsections below describe the algorithms implemented in the reference code.

### 5.2.1 Setting the “Hot” Temperature Trip Point

- Program the Thermal Hot Temperature Setting Register (THTS) as recommended in the latest Mobile Intel® 915 Express Chipset Family BIOS spec and memory reference code. Contact your Intel Field Representative to obtain this document.
- Program the Thermal Sensor Control Register (TSC) as recommended in the latest Mobile Intel® 915 Express Chipset Family BIOS spec and memory reference code. Contact your Intel Field Representative to obtain this document.
- To enable Error/SMI/SCI/INTR commands for CAT/HOT/AUX trip, set the appropriate bit in TERRCMD/TSMICMD/TSCICMD/TINTRCMD registers. Refer to latest Mobile Intel® 915 Express Chipset Family Datasheet and BIOS spec update for programming details. Contact your Intel Field Representative to obtain this document.

## 5.3 Trip Point Temperature Targets

Table 7 provides recommended trip points based upon the usage model of the thermal sensors as a thermal protection failsafe mechanism. These settings assume that the system's thermal solution has been designed to provide adequate cooling for a TDP power condition and that the settings for the silicon level thermal management are only intended to provide failsafe protection of the part beyond the capabilities of the thermal solution.

Intel's recommended trip point settings take into account the inaccuracy of the internal thermal sensors as described in Section 5.4 and are intended to cause the GMCH to initiate thermal failsafe control mechanisms at the noted temperatures under the worst case accuracy, Taccuracy. Therefore, in parts which actually exhibit the worst case inaccuracy, failsafe control mechanisms may actually be initiated at a temperature which is Taccuracy below the nominal trip point.

**Table 7. Recommended Programming for Available Trip Points**

| Zone         | Nominal Trip Points   | Recommended action  |
|--------------|---|---|
| Catastrophic | $T_{Catastrophic} = T_{C-MAX} + 41^{\circ}C - T_{accuracy} = 133^{\circ}C$  | Halt operation  |
| Hot          | $T_{Hot} = T_{C-MAX} + 3^{\circ}C + T_{accuracy} = 121^{\circ}C$  | Initiate throttling   |
| Aux          | Aux OEM decision, based on OEM criteria (for example: $T_{aux} = \text{Temp at which an auxiliary fan should be turned on}$ ) | OEM decision, based on OEM criteria (for example: turn on an auxiliary fan) |

Crossing a trip point in either direction may generate several types of interrupts. Each trip point has a register which can be programmed to select the type of interrupt to be generated.

Crossing a trip point may also initiate hardware-based throttling without software intervention.

## 5.4 Thermal Sensor Accuracy

Thermal sensor accuracy, Taccuracy, for GMCH is  $\pm 13^{\circ}C$  for temperature range  $80^{\circ}C$  to  $133^{\circ}C$ . This value is based on product characterization and is not guaranteed by manufacturing test.

Software has the ability to program the Tcat, Thot, and Taux trip points, but these trip points should be selected with consideration for the thermal sensor accuracy and the quality of the platform thermal solution. Overly conservative (unnecessarily low) temperature settings may unnecessarily degrade performance due to frequent throttling, while very aggressive (dangerously high) temperature settings may fail to protect the part against permanent thermal damage.

## 5.5 Thermal Throttling Options

The GMCH has two independent mechanisms that cause system memory bandwidth throttling. The first is GMCH thermal management to ensure that the chipset is operating within thermal limits. The mechanism can be initiated by a thermal sensor (internal or external) trip or by GMCH usage exceeding a programmed threshold via a weighted input averaging filter. The second is DRAM Thermal management to ensure that the DRAM chips are operating within thermal limits. Throttling can be initiated by DRAM activity measurement exceeding a programmed threshold.

Another possible usage model targets skin temperature control near memory. Throttling can be initiated by an external thermal sensor trip or by dram activity measurement exceeding a programmed threshold.

## 5.6 THRMTRIP Operation

Assertion of the GMCH's THRMTRIP# (Thermal Trip) indicates the GMCH junction temperature has reached a level beyond which damage may occur. Upon assertion of THRMTRIP#, the GMCH will shut off its internal clocks (thus halting program execution) in an attempt to reduce the GMCH core junction temperature. Once activated, THRMTRIP# remains latched until RSTIN# is asserted. The GMCH THRMTRIP# and CPU THRMTRIP# signals connect to ICH6-M.

# Conclusion

# 6

---

As the complexity of computer systems increases, so do power dissipation requirements. The additional power of next generation systems must be properly dissipated. Heat can be dissipated using improved system cooling, selective use of ducting, and/or passive heatsinks.

The simplest and most cost-effective method to improve the inherent system cooling characteristics of the Mobile Intel® 915GM/915GME/910GMLE Express Chipset GMCH is through careful design and placement of fans, vents, and ducts. When additional cooling is required, component thermal solutions may be implemented in conjunction with system thermal solutions. The size of the fan or heatsink can be varied to balance size and space constraints with acoustic noise.

This document has presented the conditions and requirements to properly design a cooling solution for systems that implement the 915GM/915GME/910GMLE GMCH. Properly designed solutions provide adequate cooling to maintain the 915GM/915GME/910GMLE GMCH case temperature at or below thermal specifications. This is accomplished by providing a low local-ambient temperature, ensuring adequate local airflow, and minimizing the case to local-ambient thermal resistance. By maintaining the 915GM/915GME/910GMLE GMCH case temperature at or below those recommended in this document, a system designer can ensure the proper functionality, performance, and reliability of this chipset.

# Enabled Suppliers

# A

Table 8 lists the enabled suppliers for the Mobile Intel® 915GM/915GME/910GMLE Express Chipset GMCH reference thermal solution.

**Table 8. Mobile Intel® 915GM/915GME/910GMLE Express Chipset GMCH Reference Design Heatsink Enabled Suppliers**

| Part                           | Intel Part Number | Supplier      | Contact Information   |
|--------------------------------|-------------------|---------------|---|
| Aluminum Heatsink <sup>1</sup> | NA                | CoolerMaster* | Wendy Lin (USA)<br>510-770-8566<br><a href="mailto:wendy@coolermaster.com">wendy@coolermaster.com</a>   |
| Thermal Interface (PCM45F)     | NA                | Honeywell*    | Paula Knoll<br>858-279-2956<br><a href="mailto:Paula_knoll@honeywell.com">Paula_knoll@honeywell.com</a>   |
| Heatsink Attach Clip           | A69230-001        | CCI/ACK*      | Harry Lin (USA)<br>714-739-5797<br><a href="mailto:hlinack@aol.com">hlinack@aol.com</a><br>Monica Chih (Taiwan)<br>866-2-29952666, x131<br><a href="mailto:Monica_chih@ccic.com.tw">Monica_chih@ccic.com.tw</a> |
|                                |                   | Foxconn*      | Bob Hall (USA)<br>503-693-3509, x235<br><a href="mailto:bhall@foxconn.com">bhall@foxconn.com</a>  |
| Solder-Down Anchor             | A13494-005        | Foxconn       | Julia Jiang (USA)<br>408-919-6178<br><a href="mailto:juliaj@foxconn.com">juliaj@foxconn.com</a>   |

**Note:**

1. Drawings may be delivered to any heatsink manufacturer for piece parts.

These vendors and devices are listed by Intel as a convenience to Intel's general customer base, but Intel does not make any representations or warranties whatsoever regarding quality, reliability, functionality, or compatibility of these devices. This list and/or these devices may be subject to change without notice.

# Mechanical Drawings

# B

Table 9 lists the mechanical drawings available in this appendix:

**Table 9. Mechanical Drawings**

| Drawing Name   | Page Number |
|--|-------------|
| Mobile Intel® 915GM/915GME/910GMLE Express Chipset GMCH Package                    | 29          |
| Mobile Intel® 915GM/915GME/910GMLE Express Chipset GMCH Aluminum Heatsink Assembly | 30          |
| Torsional Clip   | 32          |



Figure 11. Mobile Intel® 915GM/915GME/910GML Express Chipset GMCH Aluminum Heatsink Assembly

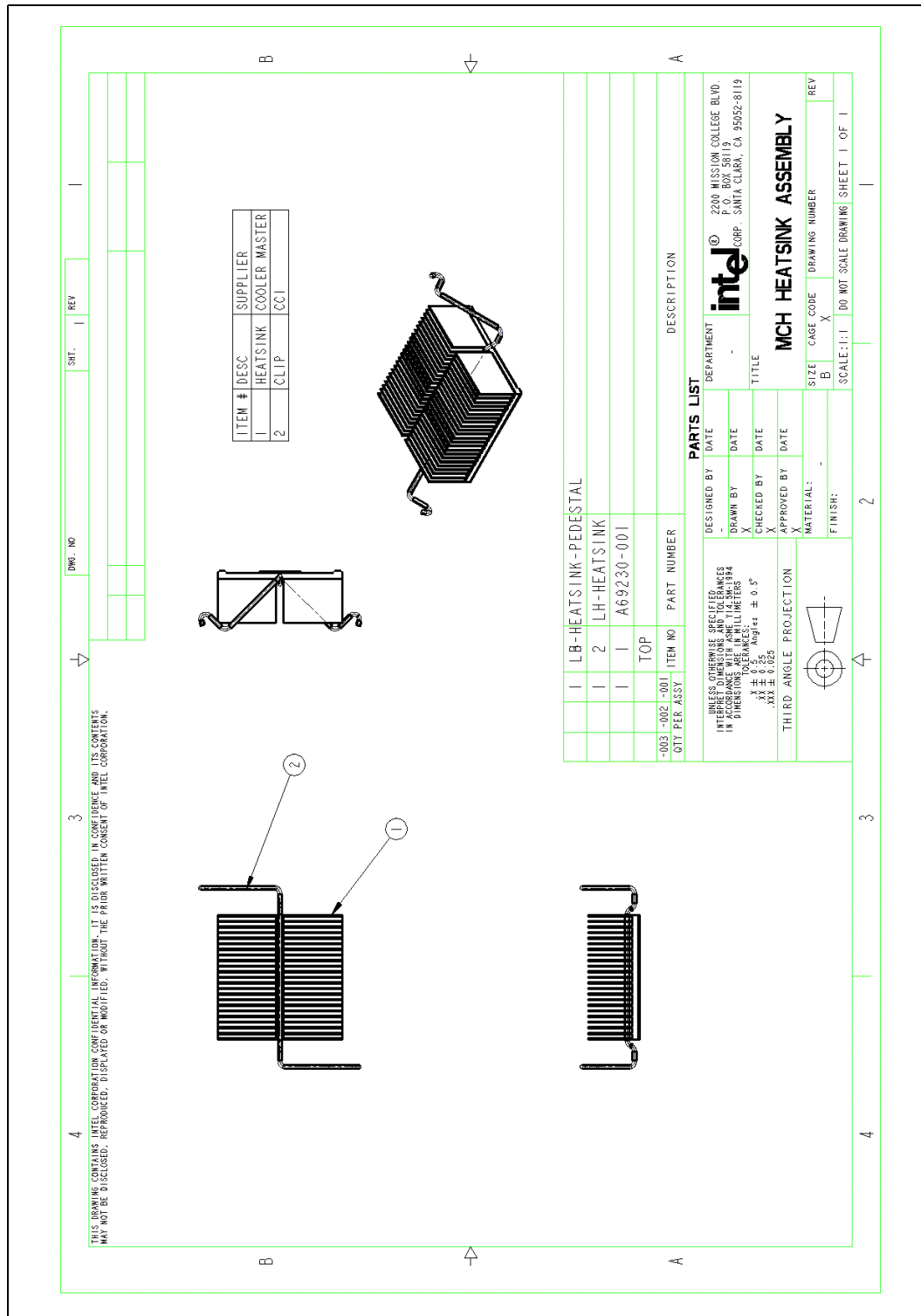

Figure 12. Mobile Intel® 915GM/915GME/910GMLE Express Chipset GMCH Aluminum Heatsink

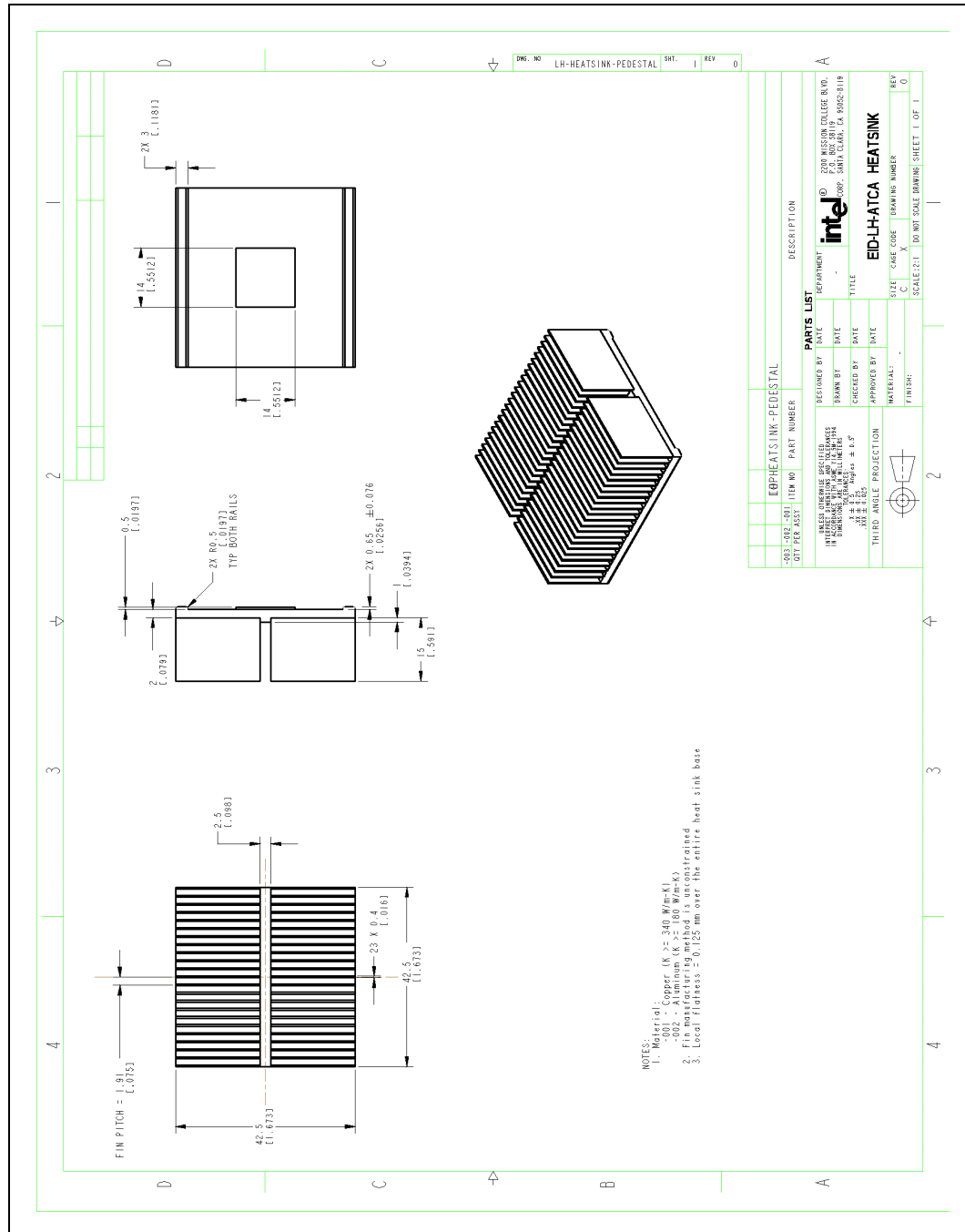

Figure 13. Torsional Clip

