



Integrated Dual Independent Display on Intel® Digital Security Surveillance Multifunction Platforms

Building cost-effective systems with the Intel® Pentium® 4 processor and the Intel® 852GME chipset on a single platform

This application brief describes a new generation of technology that is enabling lower cost-of-ownership and shorter time-to-market for development of Intel® Digital Security Surveillance systems. Intel offers multifunction application-specific building blocks for developing flexible, scalable, and cost-effective systems for video capturing and other applications such as Point of Sales (POS), all integrated into a single platform. With its newest and most powerful processors, Intel offers truly scalable platforms to meet a variety of performance needs.

Product Highlights

Performance and Functionality

- High performance for flexible software-based digital video encoding
- Support for high-quality digital video capture
- High digital storage capacity
- Remote central administration

Scalable Networking

- Support for cameras networked on wireless (802.11b) Ethernet LAN in addition to conventional CCTV cameras
- Remote upgrades over the network
- Scalability to support additional cameras

System Reliability

- System redundancy
- Off-site backup and disaster recovery
- DDR memory support with ECC

Multifunction Digital Security Surveillance + Intel® POS Designs

- Platform designs, based on Intel® Pentium® 4 processors and validated Intel® chipsets, provide the performance required for application layer

processing, MPEG-4 software encoding, network attached storage, and data encryption software.

- Intel chipsets with Dual Independent Display capability support multifunction capability in a single device: POS transactions on one screen and surveillance on the other, with a choice of LVDS or DVO display device. This helps save the space and cost of adding a second system.
- Integrated network components help enable simplified remote administration
- Unlimited networked storage of surveillance videos

Intel® Digital Security Surveillance Building Blocks

The Intel Pentium 4 processor at 3 GHz with a 533 MHz front-side bus provides excellent video encoding performance. The Intel® 852GME chipset with integrated LVDS graphics helps eliminate the requirement for additional graphic chips, to help reduce Bill of Materials (BOM) costs. Intel provides customized drivers and VBIOS, specific to the needs of this market segment.

Scalable platform designs, based on the Intel Pentium 4 processor, can also help you meet the demands of future video processing applications. Currently, application developers can purchase reference boards to begin new development in the digital security world. Intel® reference designs are available to provide Digital Security Surveillance platform designers with validated schematics and proof-of-concept designs to further cut time-to-market and design cycles.

Integrated Display Options Diagram

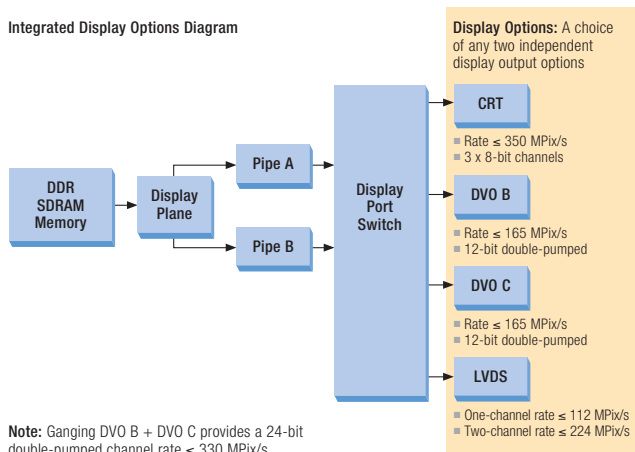

Note: Ganging DVO B + DVO C provides a 24-bit double-pumped channel rate ≤ 330 MPix/s

Example of Intel® Digital Security Surveillance, Point of Sales Demo Diagram

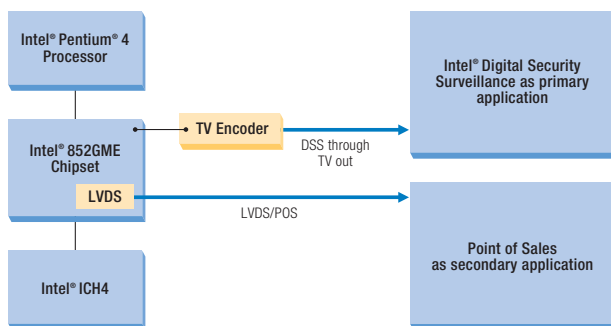

Software developers can also take advantage of Intel® Performance Primitives, software tools and a host of other optimization-related documentation to help accelerate the innovation cycle and meet today's increasing demand for performance.

Available tools include:

- Reference design schematics in Cadence Allegro® format
- Reference boards
- Intel® C++ Compilers
- Intel® VTune™ Performance Analyzer
- Intel® Integrated Performance Primitives
- Intel® Embedded Graphics Drivers

For more information, please see:

<http://developer.intel.com/design/intarch/platforms/dss/benefits.htm> and
<http://www.intel.com/design/chipsets/embedded/852gme.htm>

Cost-effective Dual Independent Display Function

The Intel Embedded Graphics Driver is an architecturally advanced graphics driver and video BIOS combination that provides graphics solutions with state-of-the-art video display support and configurability.

Both the Intel 852GME chipset and Intel Embedded Graphics Drivers support dual independent display pipe support. This offers developers:

- A concurrent display option with different images and native display timings on each display device
- A simultaneous display option supporting the same images and native display timings on each display device

This also helps provide opportunities for developers to exploit and create new, exciting applications to complement their security surveillance applications.

Multifunction Applications

While many existing Digital Security Surveillance solutions can immediately benefit from Intel platforms, further innovation and development are necessary to fully capitalize on Intel's feature-rich solutions. Examples of such multifunction applications include an Auto Teller machine, Point of Sales, and kiosks with Digital Security Surveillance.

Conclusion

As processing power improves, customers are demanding better and increased functionality from single solutions. The combination of Intel's software tools and hardware reference designs enables developers to begin value-added design work for the security surveillance market segment in a relatively short timeframe. The adoption of Intel's building blocks can further cut startup costs and help lower the total cost-of-ownership for development of multifunction Digital Security Surveillance platforms.

INFORMATION IN THIS DOCUMENT IS PROVIDED IN CONNECTION WITH INTEL PRODUCTS. NO LICENSE, EXPRESS OR IMPLIED, BY ESTOPPEL OR OTHERWISE, TO ANY INTELLECTUAL PROPERTY RIGHTS IS GRANTED BY THIS DOCUMENT. EXCEPT AS PROVIDED IN INTEL'S TERMS AND CONDITIONS OF SALE FOR SUCH PRODUCTS, INTEL ASSUMES NO LIABILITY WHATSOEVER, AND INTEL DISCLAIMS ANY EXPRESS OR IMPLIED WARRANTY, RELATING TO SALE AND/OR USE OF INTEL PRODUCTS INCLUDING LIABILITY OR WARRANTIES RELATING TO FITNESS FOR A PARTICULAR PURPOSE, MERCHANTABILITY, OR INFRINGEMENT OF ANY PATENT, COPYRIGHT OR OTHER INTELLECTUAL PROPERTY RIGHT. Intel products are not intended for use in medical, life saving, or life sustaining applications. Intel may make changes to specifications and product descriptions at any time, without notice.

* Other names and brands may be claimed as the property of others.

Copyright © 2004 Intel Corporation. All rights reserved.

Intel, the Intel logo, Pentium, and Intel VTune are trademarks or registered trademarks of Intel Corporation or its subsidiaries in the United States and other countries.

Printed in USA.

0304/0C/DC/PDF

Please Recycle

301303-001