

Neusoft Telecom BSS Virtualization Performance on the Intel® Xeon® Processor 5500 Series with VMware

Neusoft

vmware

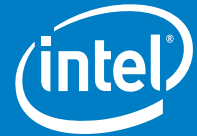

Neusoft Telecom BSS on Intel® Xeon® processor 5500 series in virtualized environment

Neusoft is the leading IT solutions & services provider in China. Neusoft Telecom BSS (Business Support System) is an offering of a traditional BSS system for bill management in telecom industry targeting large scale telecom operators. This paper discusses how Intel and Neusoft addressed the challenges in the telecom industry with the use of Intel® Xeon® processor 5500 series.

Challenges

Telecom industry is one of the fastest growing markets in China with a huge user-base. China telecom operators face several challenges:

- China Telecom operators require high quality and high performance solutions to fit the needs of fast growing end-users.
- China Telecom operators face fierce competition, require solutions to be easier to manage and maintenance, lower the TCO.

These challenges require telecom solution providers to improve the solution manageability, reliability and performance.

Solution

To improve customer satisfaction, Neusoft collaborated with Intel to optimize their Neusoft Telecom BSS solution stack. Intel engineers closely worked with Neusoft engineers in defining a virtualized reference architecture based on Intel® Xeon® processor 5500 series and Intel® Virtualization Technology. Figure 1 illustrates the virtualization solution architecture.

Neusoft constructed an entire BSS system architecture based on 2 quad-core Intel® Xeon® processor 5500 series as shown in Figure 2. The hypervisor used was build #140815 of VMware's ESX Server, a version still under development (This version has support for Intel® Xeon® processor 5500 series features such as Intel® Hyper-Threading Technology, Intel® QuickPath Technology, Intel® Turbo Boost Technology and Intel® Virtualization Technology). System configuration included 4 virtual machines on Intel® Xeon® processor 5500 series and Intel® Xeon® processor E5440 series, each running RHEL5.2 x64bit Guest OS.

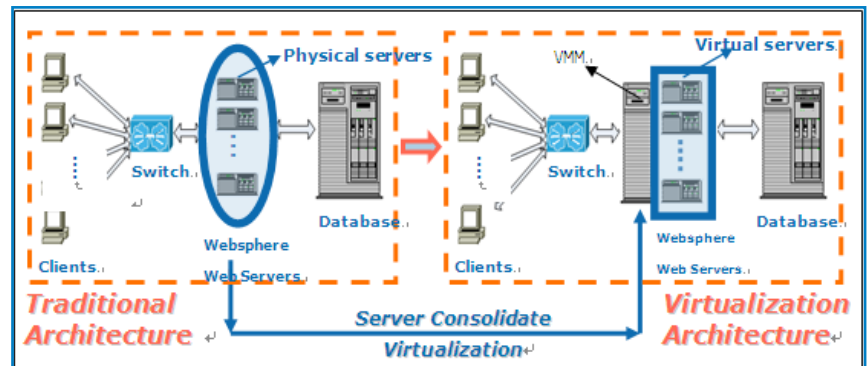

Figure 1: Neusoft Telecom BSS virtualization reference architecture

"Neusoft Telecom BSS integrated virtualization technology as a key part of the solution and it is exciting to see the new features of Intel® Xeon® processor 5500 series help our product to gain performance boost. According to the tests, features such as Intel® HT, Intel® EPT and Intel® Turbo Boost technology all benefit the performance a lot. It is really a wonderful platform."

-Yu Hongyong, Director of Neusoft Solution Readiness Center

How Intel Benefits Neusoft Telecom BSS

The architecture of Intel® Xeon® processor 5500 series has been optimized to show great performance improvement with lower power consumption, reduce I/O operation time, and support more threads. At the same time, Intel® Xeon® processor 5500 series also offers greatly improve virtualization support, giving users better experience under virtualization environment.

Neusoft Telecom BSS has been tuned and optimized to take advantage of Intel® Xeon® processor 5500 series features, such as Intel® Hyper-Threading Technology, Intel® QuickPath Technology, Intel® Turbo Boost Technology, Intel® EPT Technology and Intel® VT-d etc.

Performance Results

Using the Intel® Xeon® processor 5500 series based platform, Neusoft Telecom BSS achieved a performance improvement of up to 2.15x¹ over the previous-generation Intel® Xeon® processor 5440 series.

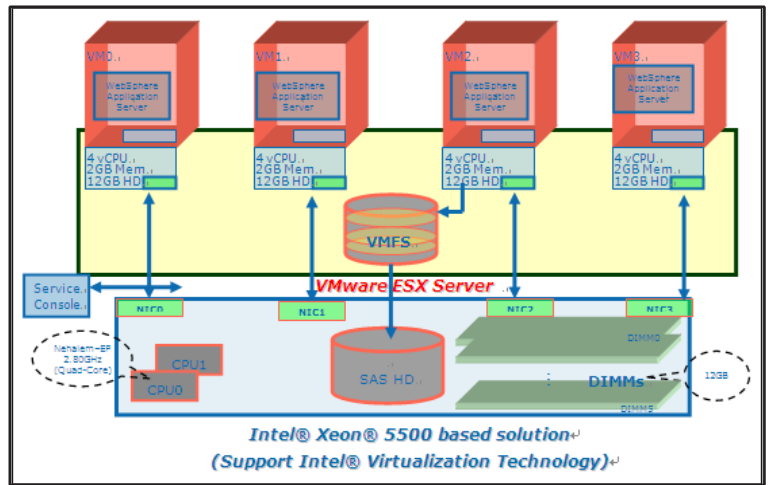

Figure 2: Neusoft Telecom BSS virtualization solution on Intel® Xeon® processor 5500 series

Neusoft Telecom BSS on Intel® Xeon® processor 5500 series (2.8 GHz) shows great performance and power advantages:

- Supports more concurrent users: comparing to previous generation processor, Intel® Xeon® processor 5500 series shows 2.15x¹ performance improvement.
- Power Efficiency: Intel® Xeon® processor 5500 series also show an improvement of 136% in power savings when compared to Intel® Xeon® processor 5440 series.

Intel® Virtualization Technology features have also helped Neusoft to implement functions like fast-deployment, fast recovery and effective isolation, thus improving the BSS solution manageability and reliability. With the addition of Intel® Virtualization Technology features in Intel® Xeon® processor 5500 series, Neusoft BSS solution has gained a significant performance gain.

Neusoft Telco BSS Performance

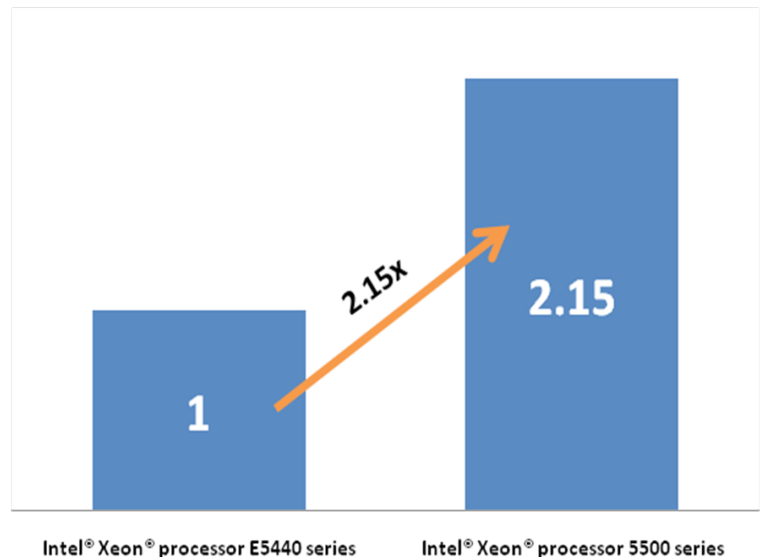

Figure 3: Neusoft Telecom BSS Virtualization Performance
Source: Intel Internal measurements, February 2009

“Performance is critical for telecom applications. Our Neusoft Telecom BSS system with VMware ESX Server requires high performance servers to afford everyday high stress routines. It is glad to see that Intel® Xeon® processor 5500 series can provide exciting computing capability to our product. The performance boost of 2.15x speedup versus Intel® Xeon® processor E5440 series is impressive.”

-Liu Dalong, Sr. Engineer Neusoft Telco Division

Performance Test Configuration Table		
Hardware Configuration		
Platform	Intel Software Development Platform	Intel Software Development Platform
Processor:	Intel® Xeon® processor 5500 series	Intel® Xeon® processor E5440 series
Processor Details:	2.8GHz	2.83GHz
Cores per Processor:	2	2
SMT:	Yes	N/A
Turbo Boost:	Yes	N/A
NUMA:	Yes	N/A
EPT:	Yes	N/A
VT-D:	Yes	N/A
Memory:	6 x 2GB	6 x 2GB
Memory Details:	DDR3-1066	Fully-Buffered DDR2 667
Software Configuration		
Hypervisor:	VMware ESX Server build #140815	VMware ESX Server build #140815
Guest Operating System:	RHEL5.2 x86-64	RHEL5.2 x86-64

1 Source: Intel Internal measurements, February 2009 Intel® Xeon® processor X5500 series, 2.8GHz; 12GB (6x2GB) DDR3-1066 MHz, vs. Intel® Xeon® processor E5440 series, 2.83GHz; 12GB (6x2GB) DDR2-667 MHz

Performance tests and ratings are measured using specific computer systems and/or components and reflect the approximate performance of Intel products as measured by those tests. Any difference in system hardware or software design or configuration may affect actual performance. Buyers should consult other sources of information to evaluate the performance systems or components they are considering purchasing. For more information on performance tests and on the performance of Intel products, visit <http://www.intel.com/performance/resources/limits.htm> or call (U.S.) 1-800-628-8686 or 1-916-356-3104.

Relative performance is calculated by assigning a baseline value of 1.0 to one benchmark result, and then dividing the actual benchmark result for the baseline platform into each of the specific benchmark results of each of the other platforms, and assigning them a relative performance number that correlates with the performance improvements reported.

Intel processor numbers are not a measure of performance. Processor numbers differentiate features within each processor series, not across different processor sequences. See http://www.intel.com/products/processor_number for details.

Intel® Virtualization Technology requires a computer system with an enabled Intel® processor, BIOS, virtual machine monitor (VMM) and, for some uses, certain platform software enabled for it. Functionality, performance or other benefits will vary depending on hardware and software configurations and may require a BIOS update. Software applications may not be compatible with all operating systems. Please check with your application vendor.

Intel® Hyper-Threading Technology requires a computer system with a processor supporting HT Technology and an HT Technology-enabled chipset, BIOS and operating system. Performance will vary depending on the specific hardware and software you use. For more information including details on which processors support HT Technology, see [here](#)

Intel® Turbo Boost Technology requires a Platform with a processor with Intel Turbo Boost Technology capability. Intel Turbo Boost Technology performance varies depending on hardware, software and overall system configuration. Check with your platform manufacturer on whether your system delivers Intel Turbo Boost Technology. For more information, see <http://www.intel.com/technology/turboboost>.

Intel products are not intended for use in medical, life saving, life sustaining, critical control or safety systems, or in nuclear facility applications. All dates and products specified are for planning purposes only and are subject to change without notice

INFORMATION IN THIS DOCUMENT IS PROVIDED IN CONNECTION WITH INTEL® PRODUCTS. NO LICENSE, EXPRESS OR IMPLIED, BY ESTOPPEL OR OTHERWISE, TO ANY INTELLECTUAL PROPERTY RIGHTS IS GRANTED BY THIS DOCUMENT. EXCEPT AS PROVIDED IN INTEL'S TERMS AND CONDITIONS OF SALE FOR SUCH PRODUCTS, INTEL ASSUMES NO LIABILITY WHATSOEVER, AND INTEL DISCLAIMS ANY EXPRESS OR IMPLIED WARRANTY, RELATING TO SALE AND/OR USE OF INTEL PRODUCTS INCLUDING LIABILITY OR WARRANTIES RELATING TO FITNESS FOR A PARTICULAR PURPOSE, MERCHANTABILITY, OR INFRINGEMENT OF ANY PATENT, COPYRIGHT OR OTHER INTELLECTUAL PROPERTY RIGHT. UNLESS OTHERWISE AGREED IN WRITING BY INTEL, THE INTEL PRODUCTS ARE NOT DESIGNED NOR INTENDED FOR ANY APPLICATION IN WHICH THE FAILURE OF THE INTEL PRODUCT COULD CREATE A SITUATION WHERE PERSONAL INJURY OR DEATH MAY OCCUR.

*Other names and brands may be claimed as the property of others.

Copyright © 2009 Intel Corporation. All rights reserved. Intel, the Intel logo, Intel. Leap ahead., Intel. Leap ahead. logo, Xeon, Intel Core, and VTune are trademarks of Intel Corporation in the U.S. and other countries.